

SFT Vibrating Wire Weighing Technology

The evolution of the revolutionary Smart Force Transducer

In the mid-1970s K-Tron revolutionized bulk solids feeding with its introduction of the first truly digital load cell specially designed for process weighing applications. Based on an innovative vibrating wire concept, the new digital technology soon proved to be a significant advance over the analog LVDTs and strain gauges then in widespread use.

In the three decades since its introduction, vibrating wire weighing technology has established a strong reputation in the process marketplace for its high accuracy, long term stability, and operational reliability.

This paper traces the evolution of vibrating wire weighing technology driven by

application and economic needs. Specific applications involving dynamic weighing and their associated challenges will be discussed, as well as a comparison to competing technologies.

Vibrating Wire Theory

The relationship between a wire's tension and its resonant frequency has been understood for a long time. With the advent of electronics, it became obvious that a vibrating wire could be used as a variable oscillator or force sensor. Today it is used in high-performance all-digital weighing scales. In such a system, the force to be measured will directly govern the tension



SFT III

of the wire, and the frequency of vibration will be detected and evaluated to obtain the result.

The resonant frequency of an ideal vibrating wire is given by the equation:

$$f_0 = \frac{n}{2l} \sqrt{\frac{T}{\mu}}$$

where 'n' is the harmonic, 'T' is wire tension, 'l' is wire length, and 'μ' is wire linear density. This relationship applies, however, only to the case of a frictionless, non-elastic wire at a constant temperature. A practical vibrating wire system exhibits a more complex behavior because it is elastic longitudinally, stiff transversely, and clamped at the end points. It will even resonate with zero tension applied. Changes in temperature will affect the resonant frequency principally due to the thermal expansion, which causes a change in wire length, but also due to the change in the modulus of elasticity of the material. Due to these issues, early systems required the use of complex reference mechanisms to achieve high accuracy. Fortunately, modern microprocessor systems make

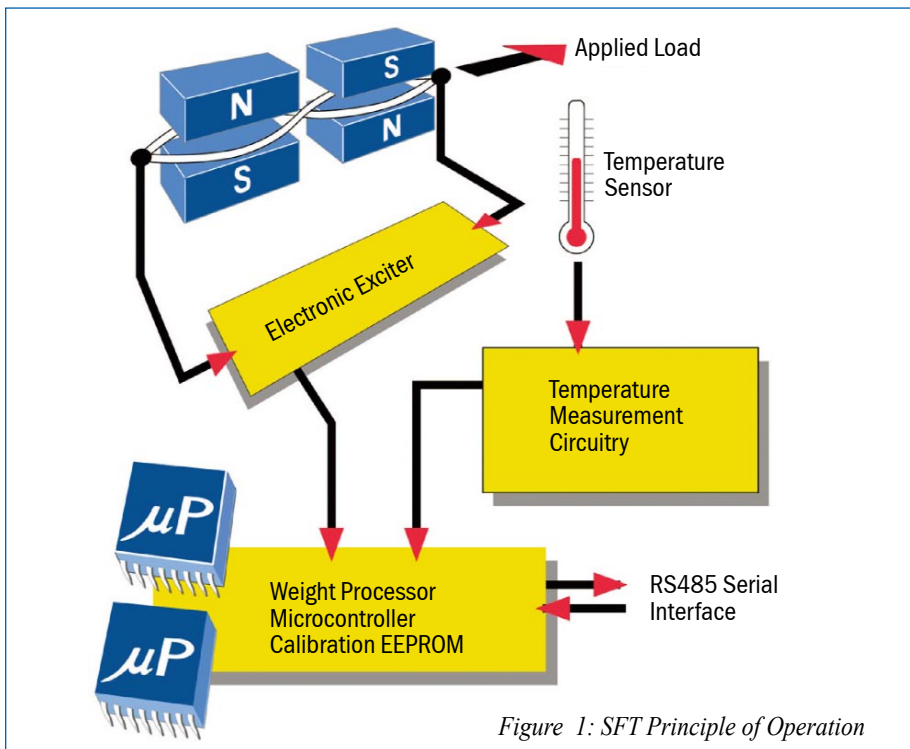

Figure 1: SFT Principle of Operation

mathematical linearization and temperature compensation schemes practical and economical.

The vibrating wires used by K-Tron exhibit a natural resonant frequency in the second harmonic, which lies within the 12 to 18 kilohertz band over the working tension range, and a high Q-factor, which exceeds 3000. (Q-factor is a measure of the quality of a particular resonance. It reflects the number of oscillations for the amplitude to decay to a 'small' value. With a high Q-factor, damping is small and the wire requires insignificant quantities of energy when the driving force is very close to the resonant frequency.)

The wires are made of beryllium copper, which is non-magnetic, but a good electrical conductor and exhibits good thermal stability. As shown in Figure 1, the wire is located in magnetic fields created by permanent magnets and is connected to an electronic amplifier circuit which causes wire motion by feeding current through the wire. Wire motion in the magnetic field causes, at the same time, generation of a millivolt level signal, which is fed back to the differential input of the amplifier to cause oscillation. This sinusoidal exciter circuit includes automatic gain control to limit the wire vibration amplitude to a safe level. A precision comparator circuit then provides a square wave output for transmission to the weight processing system. It is important to note that because of the high Q of the wire, very little energy is required to keep it oscillating. For the same reason, the exciter circuit is highly immune to variations in supply voltage and circuit component parameters as well as mechanical or acoustic disturbances to the wire.

Although the high Q factor cited for the vibrating wire prevents disturbances from causing frequency deviations, it does not guarantee that the wire will not vibrate in other harmonic modes or in another plane. These potential problems are prevented by positioning the magnetic poles along the wire and the use of a wire having a rectangular cross section. The wire is guarded against the effects of parasitic resonances

elsewhere in the system by mounting its end masses on highly refined mechanical filters. Due to the extremely low deflection of the wire (0.001 mm), its fatigue life is essentially unlimited. In spite of the low deflection, the high acceleration due to its high vibration frequency keeps any foreign particles from resting on the wire.

A major advantage of a vibrating wire over a strain element as a force sensor is the fact that although each might typically elongate by 0.1% under a full capacity load, the elongation directly governs the output of the strain gauge, but has an insignificant effect on the frequency output of the vibrating wire. Consequently, the further elongation that occurs over time due to metallic creep directly affects the measurement result of a strain gauge but is invisible in the case of a vibrating wire itself. As a practical matter, the creep exhibited by a vibrating wire transducer system will come from the other elements in the force measurement path. The fact that there are no non-metallic bonding materials used makes the system insensitive to ambient humidity and avoids long-term stability problems due to the deterioration of these materials.

Since vibrating wire transducers output a binary frequency, problems associated with the transmission, amplification and digital conversion of low-level analog signals are avoided. With an analog strain gauge, measurement resolution is in theory infinite, but is limited in practice by the analog to digital conversion. With a vibrating wire, there is no analog to digital converter so resolution becomes more a function of conversion time. The longer the count, the better the resolution. Long conversion times are impractical for real-time control, so period measurement is used. Measuring a single period with high precision would be costly, so there have been several techniques developed to precisely measure the time to count an integer number of periods.

An additional and important practical advantage of the vibrating wire transducers discussed here is that they do not require any field calibration over their operating life.

Technology Timeline

Generation 1: 1976

The Digital Mass Transducer MK-I

- Industry's first true digital weight sensor
- No field calibration required



1976 Digital Mass Transducer MK-I with two vibrating wires

K-Tron's Digital Mass Transducer (DMT) was the process industry's first commercial vibrating wire load cell. The DMT differs from virtually all other weighing transducers in that it measures mass rather than force. This is possible because it measures the ratio of the weight force of the unknown mass to the weight force of a reference mass internal to the transducer. As a result, the transducer can weigh accurately when off level or subject to variations in gravitational acceleration due to geographic location or vibration. Although the weight force seen by the transducer is affected by these conditions, the weight force of the internal reference mass is affected by the same degree and thus the ratio remains the same.

The DMT system is best explained by means of a simple hanging representation as shown in Figure 2. The frequency of each vibrating wire is governed by its own tension according to the non-linear relationship given by Equation 1 from the previous section. The wire tensions are affected by both the weight force P from the reference mass p and the weight force X from the unknown mass x but not in the same manner. Due to the angular relationship of the elements, both wires are preloaded equally by force P, but an increase in force X will result in an increase in the tension of wire 1 and a much smaller decrease in the tension of wire 2. When the relative magnitudes of the forces involved and the proper angles

are selected, the relationship between the frequency ratio f_1/f_2 and the force ratio X/P is fairly linear over large portions of the curve.

At the time of the DMT's development in the early 1970s, this was extremely important since linearization in electronic hardware or software was economically impractical. As the design was implemented, the equation to calculate mass in kilograms from the transducer output is:

$$m = \frac{256 f_1}{f_2} - 260$$

where 'm' is mass, and 'f₁' and 'f₂' are the frequencies of wires 1 and 2 respectively. The simplicity of the equation allowed for the calculation to be done in CMOS digital logic. In order to provide for faster weight conversion times and high precision, the f₁ frequency was multiplied by 256 using a phase locked loop multiplier circuit and the resulting high frequency was used to measure an integer number of periods of the f₂ frequency.

With the techniques available at the time, the DMT could achieve a resolution of as much as 1:192,000 in 2.5 seconds. The range of the DMT was only 6 kg, so higher loads required that the transducer be assembled into a conventional lever type scale mechanism. Even for applications of 6 kg or less, the DMT required a protective enclosure as it was not sealed. The electrical output of the DMT was a 4-wire interface, with one pair for each frequency. Each frequency was transmitted via a frequency modulated current. The current source from the control unit provided power for the transducer and allowed for long wire runs without the problem of voltage drop. Due to the cost and complexity of the electrical interface and weight processing electronics, only one DMT could be interfaced to the control unit.

The DMT was a highly refined electromechanical transducer. In its cast and machined brass housing were almost 100 precision components. The ratio measurement technique reduced the effects of

temperature and vibration. Even so, after assembly the unit required twelve individual hand adjustments to compensate for manufacturing tolerances, material property variance and temperature effects. Its performance and reliability were excellent, but it was costly to produce.

Generation 2: 1980

The Digital Mass Transducer MK-II

- 1:1,000,000 resolution in 1.3 seconds
- Real-time linearization



At the time the DMT was developed, microprocessors were in their infancy and very expensive. As their cost came down, the microprocessor provided the opportunity to lower the manufacturing cost and improve the performance of the DMT. The non-linearity of the DMT was mainly caused by temperature effects on the housing and internal components. The microprocessor provided the ability to do the mathematics required for real-time linearization of the weight signal.

Several changes were made to the DMT which led to the Mark-II DMT. First, the housing and several other components were changed from machined brass to zinc alloy die castings. Second, a temperature sensor was put inside the housing to monitor the temperature in real-time. And finally, the

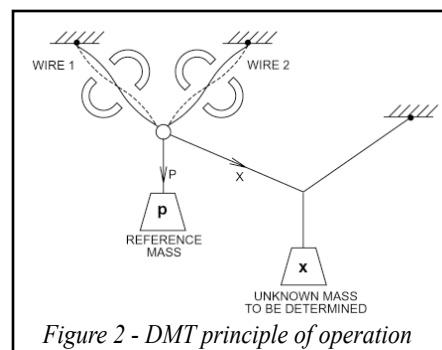

electrical interface was changed to 5-volt TTL levels to make it less expensive to interface to digital electronics. The load cell now output the two weight frequencies (f₁ and f₂) plus a new temperature frequency (ft). Many of the hand adjustments were replaced by an automated temperature chamber where the unit was linearized to correct for both weight and temperature errors. The resulting coefficients were written to an EPROM which was used with the load cell.

On the controller side, in addition to the microprocessor, a custom integrated circuit was developed to process the three frequencies more efficiently and with greater resolution. With the EPROM installed in the controller, the MK-II DMT could resolve weight to 1 PPM in 1.3 seconds. At lower resolutions the sample time was proportionally faster. The sampling technique was similar to the DMT but the custom integrated circuit could handle higher frequencies and has larger count registers.

Generation 3: 1986

The Digital Force Transducer

- Single wire design introduced
- 1:1,000,000 resolution in 0.125 seconds



The need to drive cost down further and the experience with the linearization techniques of the Mark-II DMT resulted in the realization that similar accuracy could be achieved with a single vibrating wire transducer. The Digital Force Transducer (DFT) with only one wire and no reference mass could not claim to be a true mass measuring transducer. However, with improved manufacturing techniques, fewer parts to introduce errors and refined linearization algorithms the DFT could achieve a resolution of 1 PPM in 125 milliseconds. This was

achieved by measuring an integer number of periods of the weight frequency using an 8 MHz crystal oscillator as the time base. The electrical interface was simplified to two frequencies, a weight frequency f_w and a temperature frequency f_t .

Without an internal reference mass, the DFT had no way itself to filter out external plant vibration. But with the capability of faster sampling times, this task was taken up by the feeder controller. In practice, the DMT was only effective at compensating for vibration when its reference mass and external load had a matched damping factor. The DFT still required a companion memory IC with its linearization and temperature compensation data. As with the MK-II DMT, the chip was a separate component that was installed in the controller. It was very easy to lose the IC or mismatch it with another transducer. The DFT was a replacement for the DMT transducers and still required a protective enclosure or a lever type scale for ranges above 6 kg loading.

Generation 4: 1988

The Smart Force Transducer I

- Standalone RS-485 networking introduced
- Integrated electronics



Several attempts were made to eliminate the scale mechanism. Putting a loss-in-weight feeder and its hopper on a scale was fine for a small feeder, but for a large feeder the system became very top-heavy. This presented serious problems for stability. Each time the feeder was refilled with material, it would swing back and forth like an inverted pendulum. Aside from the stress that this put on the scale mechanism, the weight signal was unusable for control of the feeder during this time. The solution was to hang the feeder and hopper from

a three-point suspension system as was typical with strain gauge systems. Since the DFTs could not be wired parallel like strain gauges, an even more flexible solution was developed.

The Smart Force Transducer I (SFT-I) was developed as a stand-alone network connected weighing device. Each load cell had its own microcontroller, custom frequency processor, calibration memory, and voltage regulator. The electrical interface chosen was an RS-485 serial channel which could support 32 devices on the network with speeds up to 1 megabit per second and distances up to 2000 feet. Plus, with the calibration constants embedded in the device using nonvolatile memory, they could no longer be misplaced. The various models of SFT were made watertight and dust-proof so external protection was no longer necessary. Further mechanical improvements were also made by integrating the mounting of the vibrating wire and the required force reduction mechanism into a simple assembly based on a thin etched beryllium copper frame.

The ability to network several load cells on one wire opened up several interesting possibilities. Now, hanging a feeder from three or more load cells was no problem. In fact, multiple SFTs on one cable do not have to be treated as a single weighing system. The summing of any or all of the weights is at the discretion of the controller communicating with the load cells. This solves the problem with the gravimetric flow meter and twin scale weigh belt feeder, for example, which need to have each weight processed independently. Also, the load cells which are networked together do not need to be of the same full scale capacity to be summed correctly. For a low cost loss-in-weight feeder system, one 68000 microprocessor running four copies of the algorithm is able to control four motor drives and communicate with twelve SFTs on four separate feeders. Each feeder and its weighing system is completely independent of the others.

Of course true real-time control is not possible without knowing precisely when

things happen. Since the scale is now a standalone device the controller does not have control of exactly when the weight sample is taken. This necessitates the use of time-stamped data. All weight data is transmitted with a precise time-stamp from the SFT. For multiple SFT systems where a scale system is comprised of two or more SFTs, synchronization is required to avoid aliasing. A novel synchronization scheme is implemented to guarantee that the timing error between SFTs is much less than 1 millisecond.

Generation 5: 1998-today

The Smart Force Transducer II/III

- Up to 1:4,000,000 resolution in 0.08 seconds
- Sophisticated digital filtering



The most recent improvements to the Smart Force Transducer were the result of a new custom integrated circuit which allowed continuous measurement and digital filtering capability at even higher sample rates. Previously there were short gaps of time between capturing the wire frequency, processing the weight, and restarting the frequency capture. The new system is able to capture an integer number of periods of the weight frequency using a 30 MHz reference frequency and never miss a single pulse. The result is truly continuous measurement. No weight information is lost, unlike a periodically sampled system. Internal to the load cell, the weight is captured, linearized, and temperature compensated 112 times per second and input to a digital low-pass filter. The filter has a selectable cutoff frequency and the controller can request a weight reading every 80 to 4500 milliseconds to reduce the effects of plant vibration.

For this latest generation, weighing

resolutions up to 1:4,000,000 are now possible.

These advancements have been incorporated into both the SFT II and SFT III designs. Unlike the SFT II design where the measured load is applied at the sensor's midpoint such as in multi-point loss-in-weight feeders, the SFT III has been specially designed for single-point weighing applications for use in cantilevered or single-point applications where the load may be applied non-axially such as in centrally mounted loss-in-weight feeders in plastics extrusion or compounding blending operations, weigh-belt feeders, or gravimetric flow meters.

Application to Dry Bulk Material Feeders and Meters

The vast majority of continuous gravimetric feeders in operation today fall into two categories: loss-in-weight feeders and weigh belt feeders. A third device also used to control a continuous feeder is a gravimetric flow meter. The flow meter measures the gravimetric flow of a material, and its output signal is then typically processed through a PID controller whose output drives a material feeding device. The operating principles of these devices are all different and as such, place different demands on the weighing system.



To illustrate the requirements of the weighing systems considered in this paper, it is helpful to be somewhat familiar with the operating principles of the feeding equipment. Below is a brief description of these operating principles and how they differ in their weighing system requirements.

Loss-in-Weight Feeders

In loss-in-weight (LIW) feeding the feeder, hopper and material are continuously weighed, and the feeder's discharge rate is controlled to match the desired feed rate. As the name implies, the system continuously loses weight. The system starts with a full hopper of material and feeding mechanism sitting on a scale, then the feeder discharges material which falls off of the scale. The controller monitors the weight on the scale and adjusts the output of the feeding device so that the weight lost per unit time matches the feed rate setpoint. The basic equation used to determine the mass flow rate for a loss-in-weight feeder is:

$$\dot{m} = \frac{\Delta w}{\Delta t \times g}$$

where 'w' = weight of material, 't' = time and 'g' = gravitational constant. When the weight on the scale drops to some predetermined minimum level, the controller will request that the hopper be refilled with material. During the refill cycle the feeder continues to discharge material as the hopper is filled with material, either automatically or manually, to some predetermined maximum weight limit. Clearly, during the refill cycle the controller cannot determine through the weight signal alone the rate at which the feeder is discharging material, so other techniques are used to maintain accurate feeding during this time.

Now consider some special weighing aspects pertaining to loss-in-weight feeding. Whether there are multiple load cells supporting the feeder, or a single platform type scale, there is only one weight signal from the LIW feeder. If there are multiple load cells, their signals must be summed into a single weight. This summing is easily

accomplished with most any type of load cell.

The weight signal from the LIW feeder often covers nearly the entire weighing range of the load cell as the feeder runs from full to its refill point. Therefore, the linearity of the load cell is very important. Linearity refers to the quality of delivering identical sensitivity throughout the weighing capacity of the scale. Any linearity error in the weighing system will translate directly into a feeding error for the LIW feeder.

The resolution of the weighing system can be very important in the LIW feeder if the massflow setpoint is small in comparison to the load cell's weighing range. For example, if the loss-in-weight feeder, when full of material, weighs 80 kilograms, the range of the weighing system might be 150 kilograms. If the massflow setpoint for this feeder is small, say 2.0 kg/hour, the resolution of the system becomes very significant. In this case the setpoint is only 0.022% full range/minute or 0.00037% full range/second. Another way to look at resolution is in parts per million (ppm). The vibrating wire load cell has a typical resolution of 4,000,000 valid counts over the scale range. So continuing with the same example, the

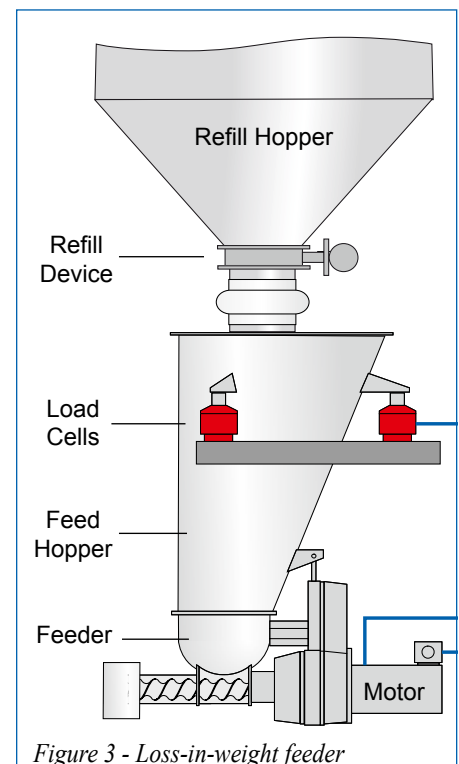

Figure 3 - Loss-in-weight feeder

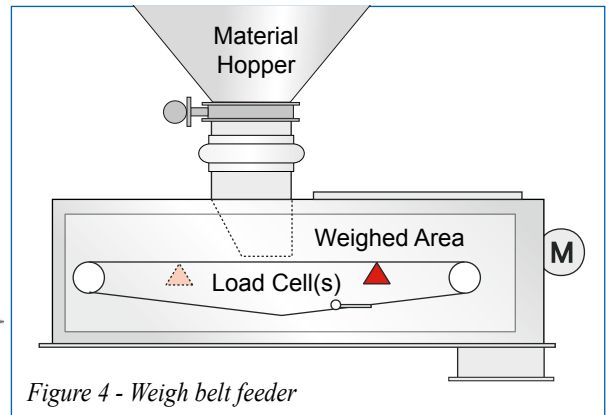

Figure 4 - Weigh belt feeder

setpoint now is 888 counts/minute or 14.8 counts/second.

Temperature drift and weight creep are less important on the LIW feeder systems because the loss-in-weight gravimetric control uses moment-to-moment changes in the weight rather than comparing the current weight to a saved reference like a tare value.

Weigh Belt Feeder

A weigh belt feeder (WBF) is typically implemented as a relatively short conveyor belt with a portion of the belt supported by a weighing device and driven by a variable speed motor. As the bulk material is transported over the weighing device, a weight per unit length is determined for that portion of the belt. Belt speed is continuously adjusted so the material falling off the end of the conveyor is fed at the desired rate. Weight per unit length is often referred to as belt load and is a function of the feeder design. The basic equation used to determine the mass flow rate for a weigh belt feeder is:

$$\dot{m} = \frac{w}{l \times g} \times s$$

where 'w' = weight of material, 'l' = length of weighed area, 's' = belt speed, and 'g' = gravitational constant. In most cases, bulk material enters the feeder through a hopper mounted above the feeder. The conveyor belt pulls material out of the hopper and through a shear gate forming the material into a more or less consistent bed depth on the belt.

The demands placed on the weighing system by the WBF are very nearly opposite those placed on the weighing system by the LIW feeder. Unlike the LIW system, the weight signal for the WBF will not traverse much of the usable range of the load cell. An operating belt feeder will output a weight signal that may not move much at all if the material is consistently loading the belt. The WBF gravimetric control operation constantly compares the current weight to a saved tare value for the empty belt. The WBF system is extremely sensitive to drift and creep. Likewise, any changes to the belt itself, such as material buildup or stretching, will change the weight of the empty belt. It may not be practical for the users of belt feeders to stop production and recalibrate the tare values frequently, so a stable weighing system is vitally important. Weigh belt feeders are often presented as lower tech devices than the LIW feeders, but the weighing requirements are usually more demanding.

One unique solution to the problem of sensitivity to drift, creep, or changes in the belt weight, is to add a second weigh deck that weighs the belt before the material is added. This allows the empty belt to be continuously re-tared and completely eliminates the problem of material buildup on the belt causing feeding errors. Also, as long as the drift or creep happens in the same direction on both weighing systems, it reduces feeding errors caused by these problems also. The addition of a second weigh deck requires handling two separate weighing systems in one feeder. Unlike the

LIW feeder, where multiple load cells are summed together, here the weights must be kept separate.

Gravimetric Flow Meter

The gravimetric flow meter is a patented device that can be used to measure the mass flow of free flowing bulk materials. The bulk material flow through the measuring instrument is aided solely by gravity, which results in very gentle handling of the material.

The principle of operation can be likened to an inclined weigh belt feeder with constant belt speed in combination with an impact plate. The bulk material enters the flow meter through a stabilization section to reduce its vertical velocity component. It then enters an upper measurement channel where it slides across an inclined surface. The upper measurement channel is suspended by a vibrating wire load cell and continuously weighed, producing the first force measurement, F_1 . Subsequently, the bulk material impacts and flows through a separate vertical measurement channel, suspended by a second vibrating wire load cell, producing force measurement F_2 . From these two continuous measurements mass flow and velocity can be calculated according to the equation:

$$\dot{m} = \frac{\sqrt{F_1 \times F_2}}{g l \times \cos \alpha}$$

where ' F_1 ' = the force on the inclined chute, ' F_2 ' = the force on the vertical chute, 'l' = length of the inclined chute, ' α ' =

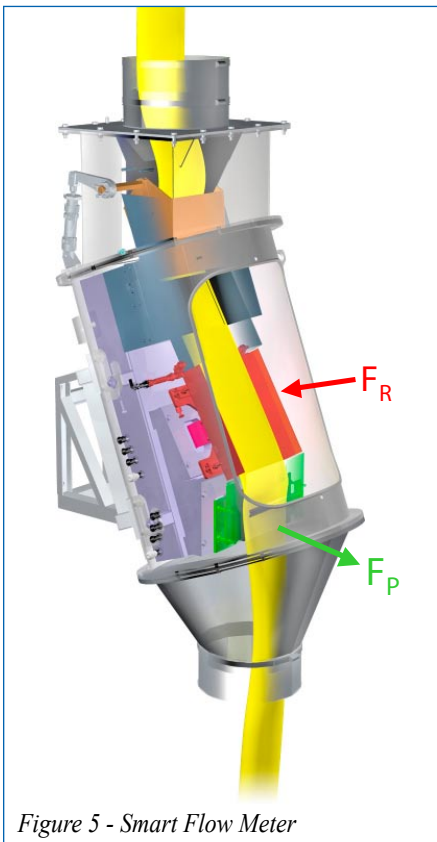

Figure 5 - Smart Flow Meter

the angle of the inclined chute, and 'g' = gravitational constant.

The demands placed on the weighing system of the flow meter are very similar to those for the weigh belt feeder. Specifically, feeder performance is degraded more due to drift and creep errors than linearity errors. The operation of the feeder requires continuous comparison of the current weight against the saved tare weights. In this case the weights of the empty chutes constitute the tare weights. Material build up is not a problem since it can automatically tare by diverting the material momentarily around the chutes. Since two independent forces are needed to solve the mass flow equation, the flow meter requires two independent weighing systems.

Whether employed as a flow meter where throughput is simply totalized, or as a feeder where a flow control device is positioned above the meter's inlet and controlled by the meter's flow measurement, periodic sampling of the load cells is sufficient only when flow is regular and consistent. When incoming flow is not con-

sistent whether due to wild flows or pulsing output from the flow control device (e.g. rotary valve at lower speeds), a periodically sampled weighing system could give erroneous results. The vibrating wire transducer is perfectly suited for dynamic applications such as this because it continuously integrates the weight measurement over time, which results in no loss of weight data. Other weighing systems, such as a simple strain gauge with a normal analog to digital converter, miss data between samples.

Conclusion

Experience has shown that the vibrating wire load cell is ideal for continuous weigh-feeding applications. It has proven to be flexible, reliable, accurate, linear, and cost effective. Measurement is truly continuous, and resolution can be as high as 1:4,000,000 in 80ms.

It is not a coincidence that all premiere weigh-feeder manufacturers throughout the world today now employ some version of the vibrating wire load cell K-Tron pioneered nearly 30 years ago.



K-TRON PROCESS GROUP

To download other papers in this series,
or for more information on
K-Tron Process Group equipment
and services, please visit

www.ktron.com

