



SMART Current Driver HiC2031ES

- 1-channel isolated barrier
- 24 V DC supply (bus powered)
- Current output up to 650 Ω load
- HART-IP and valve positioner
- Low power dissipation
- Line fault detection (LFD)
- Up to SIL 3 acc. to IEC/EN 61508



Function

This isolated barrier is used for intrinsic safety applications. The device repeats the input signal from a control system to drive HART I/P converters, electrical valves, and positioners located in a hazardous area. Digital signals are superimposed on the analog values at the field side or control side and are transferred bi-directionally. An open or short field circuit presents a high impedance to the control side to allow alarm conditions to be monitored by the control system. Line fault detection of the field circuit is indicated by a red LED and an output on the fault bus. This device mounts on a HiC termination board.

Connection

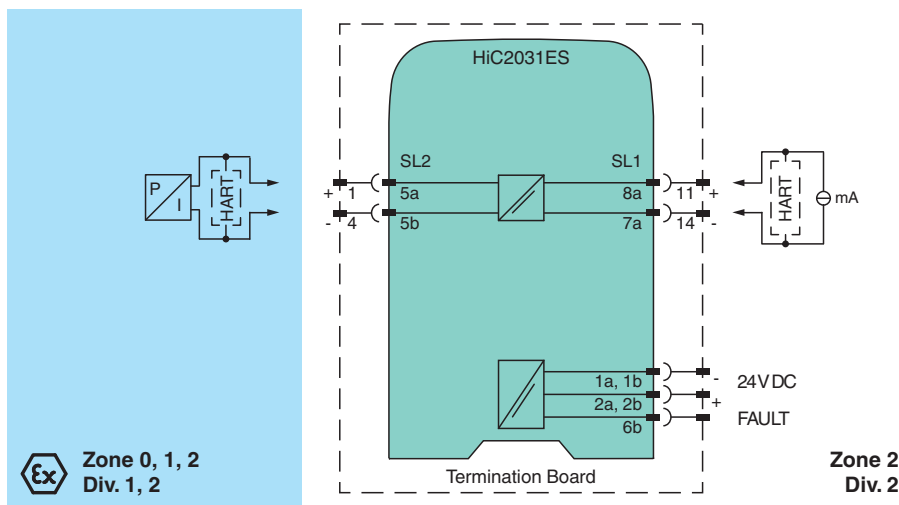

Technical Data

General specifications	
Signal type	Analog output
Functional safety related parameters	
Safety Integrity Level (SIL)	SIL 3
Supply	
Connection	SL1: 1a(-), 1b(-); 2a(+), 2b(+)
Rated voltage	U_r 19 ... 30 V DC bus powered via Termination Board
Ripple	≤ 10 %
Rated current	I_r ≤ 33 mA at 24 V
Power dissipation	≤ 700 mW at 20 mA and 500 Ω load

Release date: 2022-09-15 Date of issue: 2022-09-15 Filename: 70101789_eng.pdf

Refer to "General Notes Relating to Pepperl+Fuchs Product Information".

Pepperl+Fuchs Group
www.pepperl-fuchs.com

USA: +1 330 486 0002
pa-info@us.pepperl-fuchs.com

Germany: +49 621 776 2222
pa-info@de.pepperl-fuchs.com

Singapore: +65 6779 9091
pa-info@sg.pepperl-fuchs.com

PEPPERL+FUCHS

Technical Data

Power consumption	≤ 800 mW
Input	
Connection side	control side
Connection	SL1: 8a(+), 7a(-)
Input signal	4 ... 20 mA , limited to approx. 25 mA
Input voltage	open loop voltage of the control system < 60 V
Voltage drop	approx. 6 V at 20 mA
Input resistance	> 100 kΩ, with field wiring open or < 50 Ω
Output	
Connection side	field side
Connection	SL2: 5a(+), 5b(-)
Voltage	≥ 13 V at 20 mA
Current	4 ... 20 mA
Load	100 ... 650 Ω
Ripple	20 mV rms
Line fault detection	field wiring open or < 50 Ω and test current < 2 mA
Fault indication output	
Connection	SL1: 6b
Output type	open collector transistor (internal fault bus)
Transfer characteristics	
Deviation	at 20 °C (68 °F), 4 ... 20 mA < 0.1 % of full scale, incl. non-linearity and hysteresis
Influence of ambient temperature	< 2 μA/K (-20 ... 70 °C (-4 ... 158 °F)); < 4 μA/K (-40 ... -20 °C (-40 ... -4 °F))
Frequency range	field side into the control side: bandwidth with 0.5 V _{pp} signal 0 ... 3 kHz (-3 dB) control side into the field side: bandwidth with 1 mA _{pp} signal 0 ... 3 kHz (-3 dB)
Rise time	10 to 90 % ≤ 10 ms
Galvanic isolation	
Input/Output	safe electrical isolation acc. to IEC/EN 60079-11, voltage peak value 375 V
Input/power supply	basic insulation according to IEC/EN 61010-1, rated insulation voltage 60 V _{eff}
Output/power supply	safe electrical isolation acc. to IEC/EN 60079-11, voltage peak value 375 V
Indicators/settings	
Display elements	LEDs
Labeling	space for labeling at the front
Directive conformity	
Electromagnetic compatibility	
Directive 2014/30/EU	EN 61326-1:2013 (industrial locations)
Conformity	
Electromagnetic compatibility	NE 21:2017 EN 61326-3-2:2018 For further information see system description.
Degree of protection	IEC 60529:2001
Protection against electrical shock	UL 61010-1:2012
Ambient conditions	
Ambient temperature	-40 ... 70 °C (-40 ... 158 °F)
Mechanical specifications	
Degree of protection	IP20
Mass	approx. 100 g
Dimensions	12.5 x 106 x 128 mm (0.5 x 4.2 x 5.1 inch) (W x H x D)
Mounting	on termination board
Coding	pin 1 and 3 trimmed For further information see system description.
Data for application in connection with hazardous areas	
EU-type examination certificate	CESI 20 ATEX 007 X
Marking	Ⓜ II (1)G [Ex ia Ga] IIC Ⓜ II (1)D [Ex ia Da] IIIC Ⓜ I (M1) [Ex ia Ma] I

Release date: 2022-09-15 Date of issue: 2022-09-15 Filename: 70101789_eng.pdf

Refer to "General Notes Relating to Pepperl+Fuchs Product Information".

Pepperl+Fuchs Group
www.pepperl-fuchs.comUSA: +1 330 486 0002
pa-info@us.pepperl-fuchs.comGermany: +49 621 776 2222
pa-info@de.pepperl-fuchs.comSingapore: +65 6779 9091
pa-info@sg.pepperl-fuchs.com
 PEPPERL+FUCHS

Technical Data

Output	Ex ia	
Supply		
Maximum safe voltage	U_m	250 V AC (Attention! U_m is no rated voltage.)
Equipment		SL2: 5a(+), 5b(-)
Voltage	U_o	25.2 V
Current	I_o	100 mA
Power	P_o	630 mW
Internal capacitance	C_i	5.7 nF
Internal inductance	L_i	negligible
Certificate		CESI 20 ATEX 008 X
Marking		Ⓜ II 3G Ex ec IIC T4 Gc
Directive conformity		
Directive 2014/34/EU		EN IEC 60079-0:2018 , EN 60079-11:2012 , EN 60079-7:2015
International approvals		
UL approval		E106378
Control drawing		116-0472 (cULus)
IECEx approval		
IECEx certificate		IECEx CES 20.0008X
IECEx marking		[Ex ia Ga] IIC , [Ex ia Da] IIIC , [Ex ia Ma] I Ex ec IIC T4 Gc
General information		
Supplementary information		Observe the certificates, declarations of conformity, instruction manuals, and manuals where applicable. For information see www.pepperl-fuchs.com .

Assembly

Front view

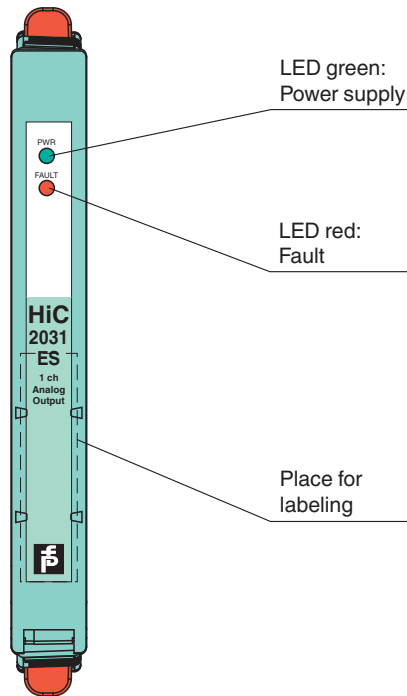

Release date: 2022-09-15 Date of issue: 2022-09-15 Filename: 70101789_eng.pdf

Safety Information



*The pins for this device are trimmed to polarize it according to its safety parameter. Do not change!
For further information see system description.*