



Solenoid Driver

HiC2871A

- 1-channel isolated barrier
- 24 V DC supply (loop powered)
- Output 45 mA at 12 V DC
- Test pulse immunity
- Up to SIL 3 acc. to IEC/EN 61508



Function

This isolated barrier is used for intrinsic safety applications. The device supplies power to solenoids, LEDs and audible alarms located in a hazardous area. The device is loop powered, so the available energy at the output is received from the input signal. The output signal has a resistive characteristic. As a result the output voltage and current are dependent on the load and the input voltage. At full load, 12 V at 45 mA is available for the hazardous area application. This device mounts on a HiC Termination Board.

Connection

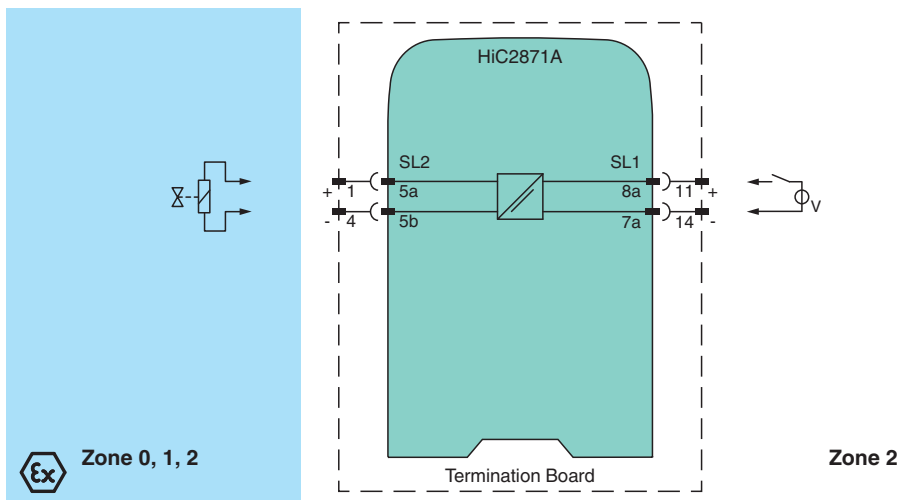

Technical Data

General specifications

Signal type Digital Output

Functional safety related parameters

Safety Integrity Level (SIL) SIL 3

Systematic capability (SC) SC 3

Supply

Connection loop powered

Rated voltage U_r 19 ... 30 V DC loop powered

Power dissipation < 1.3 W

Input

Connection side control side

Release date: 2022-09-15 Date of issue: 2022-09-15 Filename: 304977_eng.pdf

Refer to "General Notes Relating to Pepperl+Fuchs Product Information".

Pepperl+Fuchs Group
www.pepperl-fuchs.com

USA: +1 330 486 0002
pa-info@us.pepperl-fuchs.com

Germany: +49 621 776 2222
pa-info@de.pepperl-fuchs.com

Singapore: +65 6779 9091
pa-info@sg.pepperl-fuchs.com

PEPPERL+FUCHS

Technical Data

Connection		SL1: 7a(-), 9a(-); 8a(+), 10a(+)
Test pulse length		max. 2 ms from DO card
Signal level		1-signal: 19 ... 30 V DC 0-signal: 0 ... 5 V DC
Rated voltage	U_r	19 ... 30 V DC
Rated current	I_r	0-signal: typ. 1.6 mA at 1.5 V DC; typ. 8 mA at 3 V DC (maximum leakage current DO card) 1-signal: ≥ 36 mA (minimum load current DO card)
Inrush current		≤ 200 mA after 100 μ s
Output		
Connection side		field side
Connection		SL2: 5a(+), 5b(-)
Internal resistor	R_i	approx. 240 Ω
Current	I_e	≤ 45 mA
Voltage	U_e	≥ 12 V
Current limit	I_{max}	45 mA
Open loop voltage	U_s	typ. 24.6 V
Switching frequency	f	max. 10 Hz
Energized/De-energized delay		28 ms / 10 ms
Galvanic isolation		
Output/other circuits		basic insulation according to IEC/EN 61010-1, rated insulation voltage 300 V _{eff}
Indicators/settings		
Display elements		LED
Labeling		space for labeling at the front
Directive conformity		
Electromagnetic compatibility		
Directive 2014/30/EU		EN 61326-1:2013 (industrial locations)
Conformity		
Electromagnetic compatibility		NE 21:2017 , IEC/EN 61326-3-2:2018 For further information see system description.
Degree of protection		IEC 60529:2013
Protection against electrical shock		UL 61010-1:2012
Ambient conditions		
Ambient temperature		-40 ... 70 °C (-40 ... 158 °F)
Mechanical specifications		
Degree of protection		IP20
Mass		approx. 150 g
Dimensions		12.5 x 106 x 128 mm (0.5 x 4.2 x 5.1 inch) (W x H x D)
Mounting		on termination board
Coding		pin 1 and 4 trimmed For further information see system description.
Data for application in connection with hazardous areas		
EU-type examination certificate		FIDI 21 ATEX 0069X
Marking		Ⓜ II 3(1)G Ex ec [ia Ga] IIC T4 Gc Ⓜ II (1)D [Ex ia Da] IIIC Ⓜ I (M1) [Ex ia Ma] I
Output		Ex ia
Voltage	U_o	26 V
Current	I_o	110 mA
Power	P_o	715 mW
Input		
Maximum safe voltage	U_m	60 V (Attention! The rated voltage can be lower.)
Galvanic isolation		
Input/Output		safe electrical isolation acc. to IEC/EN 60079-11, rated insulation voltage 300 V _{rms}
Directive conformity		

Release date: 2022-09-15 Date of issue: 2022-09-15 Filename: 304977_eng.pdf

Refer to "General Notes Relating to Pepperl+Fuchs Product Information".

 Pepperl+Fuchs Group
www.pepperl-fuchs.com

 USA: +1 330 486 0002
pa-info@us.pepperl-fuchs.com

 Germany: +49 621 776 2222
pa-info@de.pepperl-fuchs.com

 Singapore: +65 6779 9091
pa-info@sg.pepperl-fuchs.com

 **PEPPERL+FUCHS**

Technical Data

Directive 2014/34/EU	EN IEC 60079-0:2018+AC:2020 , EN 60079-7:2015+A1:2018 , EN 60079-11:2012 , EN IEC 60079-15:2019
International approvals	
FM approval	FM 17 US 0111 X , FM 17 CA 0057 X
Control drawing	116-0442
UL approval	E106378
Control drawing	116-0447A (cULus)
IECEX approval	
IECEX certificate	IECEX EXA 17.0009X
IECEX marking	Ex ec [ia Ga] IIC T4 Gc [Ex ia Da] IIC [Ex ia Ma] I
General information	
Supplementary information	Observe the certificates, declarations of conformity, instruction manuals, and manuals where applicable. For information see www.pepperl-fuchs.com .

Assembly

Front view

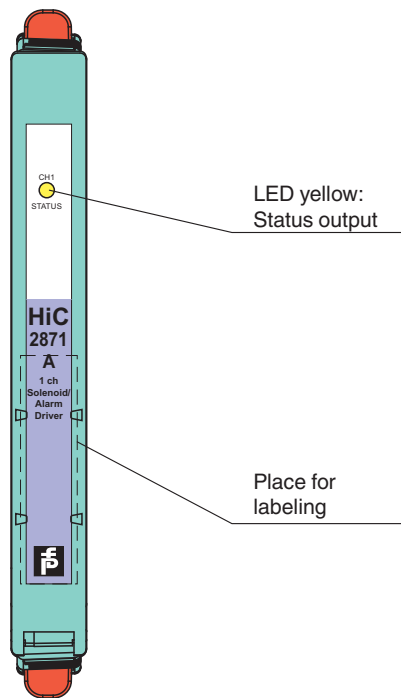

Release date: 2022-09-15 Date of issue: 2022-09-15 Filename: 304977_eng.pdf

Configuration

No user configuration available for this device.

Safety Information



The pins for this device are trimmed to polarize it according to its safety parameter. Do not change!
For further information see system description.

Characteristic Curve

Output characteristics

Output circuit diagram

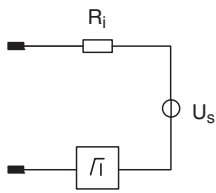

Output characteristic

