

SDVB20 Series of DC LVDT Displacement sensor

Introduction

LVDT is a high-tech product used to measure the elongation, vibration, thickness, expansion and so on, it is intended for widely application in Aerospace, Machinery, Construction, Textile, Railway, Coal mine, Metallurgy, Plastic, Chemical industry and Academic research.

DC LVDT performs excellently from 9-28 voltage DC power supply, suitable for high precision and high repeatability measurement, output standard signal of 0-5v or 4-20mA to be identified by computer or PLC. The integrated circuit is hermetically sealed in SUS 304 stainless steel sleeve, ensure that the transducers keep working accurately and reliably in hostile environment of damp and dust, corrosion, etc.



Features

- Outer diameter $\Phi 20\text{mm}$, SS 304 shell, spring-loaded
- DC single power supply, built-in excellent signal demodulator
- Three wires voltage output 0-5V or 0-10V, two wires current output 4-20mA
- Measuring range from 1mm-50mm, high resolution, excellent repeatability
- Contactless operation, long life

Applications

- Shaft jumping detection
- Hydraulic cylinder positioning
- The valve position detection and control
- Roll gap measuring
- Vehicle brake wear measurement

Specifications

Series of SDVB20 Spring-loaded	
Input Voltage	9 ~28V DC
Input Current	input current $\leq 12\text{mA}$ (Voltage output type)
	input current 4~20mA (2 wire, current output type)
Measuring range	2.5, 5, 10, 15, 25, 50
Output signal	0~5V (9 ~28V DC input voltage)
	0 ~10V (15 ~28V DC input voltage)
	4 ~20mA (2 wire, 15 ~28V DC input voltage)
	Digital output (9 ~28V DC input voltage)
Linearity	Analog output: $\pm 0.25\%$, $\pm 0.5\%$ etc optional; Digital output: 0.25%, 0.1% etc optional
Repeatability	$\leq 0.01\%$ of FS
Resolution	$\leq 0.01\text{um}$ (max), Digital output is 16 bit
Dynamic characteristics	10Hz (max)
Operating temperature	-25°C ~ +85°C
Temperature coefficient	Null point $\leq 0.01\%/^{\circ}\text{C}$
	Sensitivity $\leq 0.025\%/^{\circ}\text{C}$

Mechanical Specifications

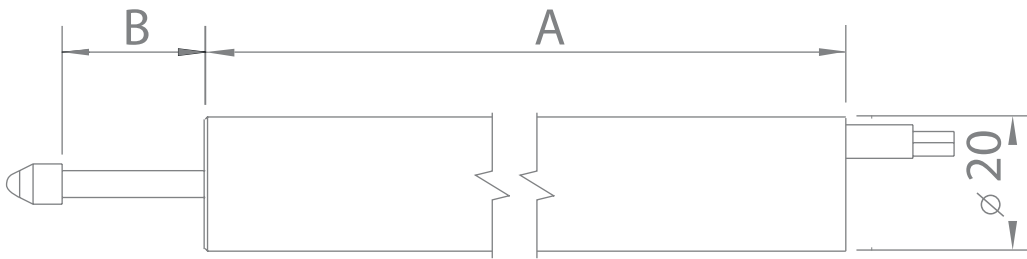

Specifications	SDVB20 series of spring-loaded					
Measuring range (mm)	2.5	5	10	15	25	50
Body A (mm)	80	90	110	130	170	210
Leader original state length B (mm)	5	8	15	22	34	60



Note

The factory default setting is that output signal maximum when the leader is move to outlet direction.

Output Characteristics

Relations of output voltage (0-5V) and displacement for series of SDVB 20 different measuring ranges:

(Input voltage 9-28VDC, 12VDC is recommended)

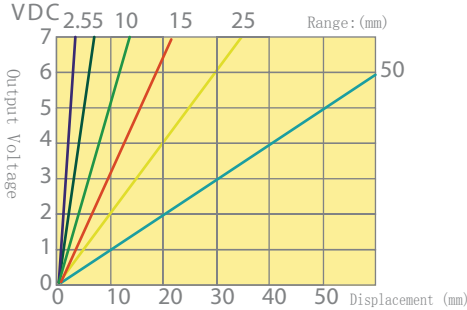

Relations of output voltage (0-10V) and displacement for series of SDVB 8 different measuring ranges:

(Input Voltage 15-28VDC, 15VDC is recommended)

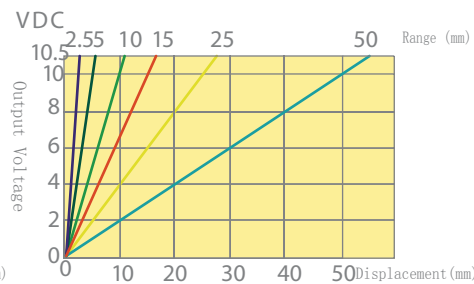

Relations between the Max loop impedance and input voltage (Current output Model)

(Input voltage 15-28VDC, 24VDC is recommended, Load impedance 500Ω)

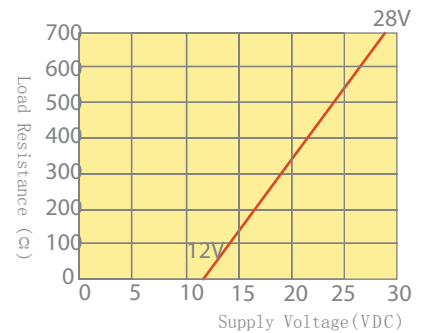

wiring



The input voltage must be within the scope of specifications. (Refer to the performance parameter table), two output types, one is socket output the other is cable directly output.

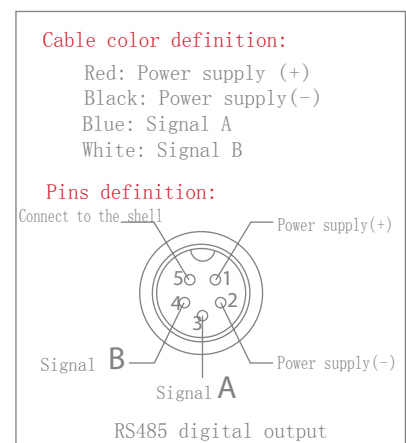
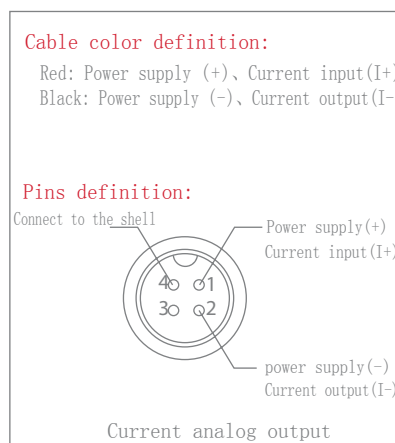
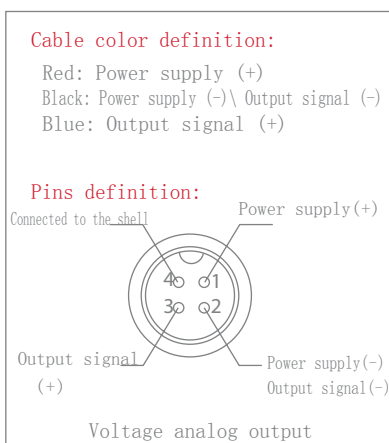

◆ Diagram for voltage output model:

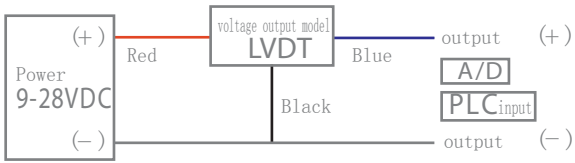

◆ Two wires current output wiring:

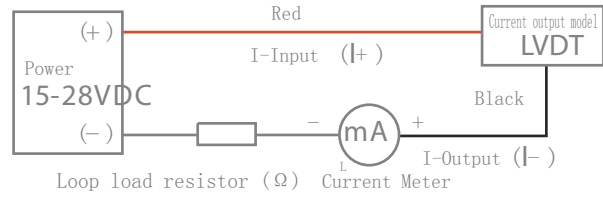

◆ PLC wiring (two wires current output):

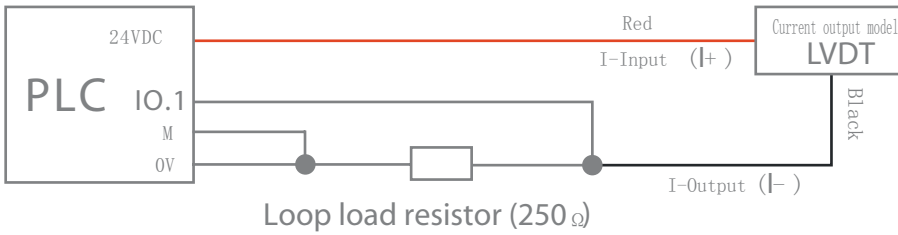

Installation



- ⚠ LVDT installations require a nonmetal materials with a low-temperature coefficient of expansion to mount the units, metal materials will influenced the products performance.
- ✔ Ready-made mounting blocks are available for all LVDT Series in our catalog; Also can defined by customers.

Dimensions of mounting block

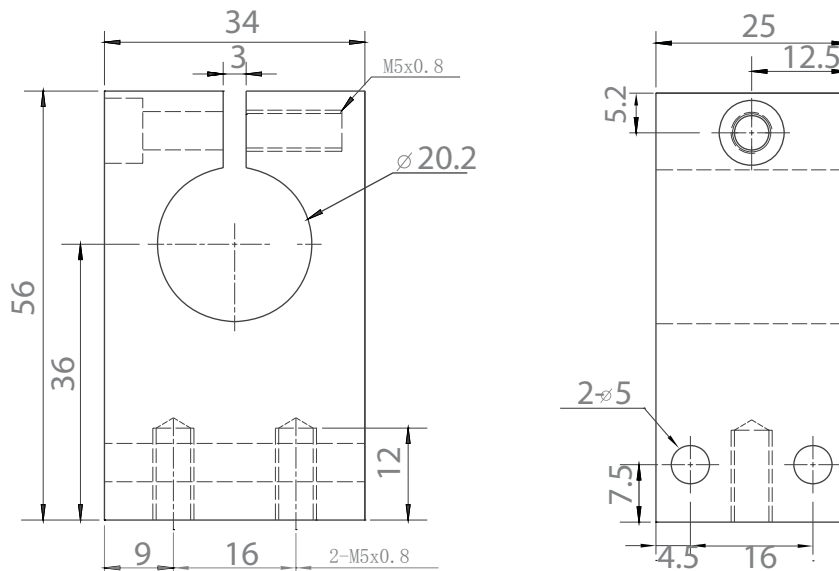

Product model selection table

SDVB20	<input checked="" type="checkbox"/>	-	<input type="checkbox"/>	<input type="checkbox"/>	<input type="checkbox"/>	<input type="checkbox"/>	-	<input type="checkbox"/>	<input type="checkbox"/>	-	<input type="checkbox"/>	<input type="checkbox"/>	<input type="checkbox"/>	Selection description	
Structure relations of electronic warehouse and coil	X													Standard type is default value; A: Double tube type, B: Electronic warehouse and coil separated type, C: No shell type, ..., Z: customized	
Measuring Range		X	X	X										Unit:mm	
Precision														A	0.25%
														B	0.50%
														C	1%
														D	3%
														E	5%
														S	0.1%(Only applies to digital output)
Output signal								X	X						See attached list one
Sensor installation specifications										X	X				See attached list two
Output type														D	Connector output
														P	Directly exit cable (default length 1m)
														M	With digital display output

Attached list one: Output signal

	<input type="checkbox"/>	<input type="checkbox"/>	
Analog output	Output model	Output range	
	A:Current output	1、4mA~20mA	
	V:Voltage output	1、0V~10V 4、-5V~5V 2、0V~5V 6、-10V~10V A、AC output	
Digital output	Output model	Data format and Baud rate	
	M:Modbus output (Factory default baud rate19200)	RTU format	ASCII
		0: 2400	A: 2400
		1: 4800	B: 4800
		2: 9600	C: 9600
		3: 19200	D: 19200
		4: 38400	E: 38400
		5: 76800	F: 76800
6: 115200	G: 115200		

Attached list two:Sensor installation specifications

<input type="checkbox"/>	<input type="checkbox"/>
C: Cylindrical	Code Thread (Outer diameter)
M: Standard thread	1 B 12
T: Fine thread	2 C 14
	3 D 16
	4 E 18
	5 F 20
	6 G 22
	7 H 24
	8 8 I 27
	9 J
	A 10 Z Customized

Selection example:

