

Pressure regulating valve, spring loaded
DN 15 - 100

ARI-PRESO® - Pressure regulating valve
Straight through with flanges

- Spring loaded
- TA - Luft TÜV-Test-No. 922-9241371

Grey cast iron
SG iron
Cast steel
Stainless steel

Fig. 753

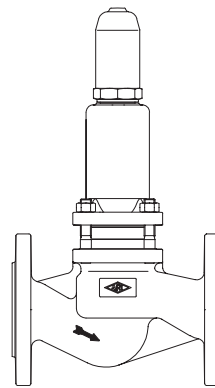

Page 2

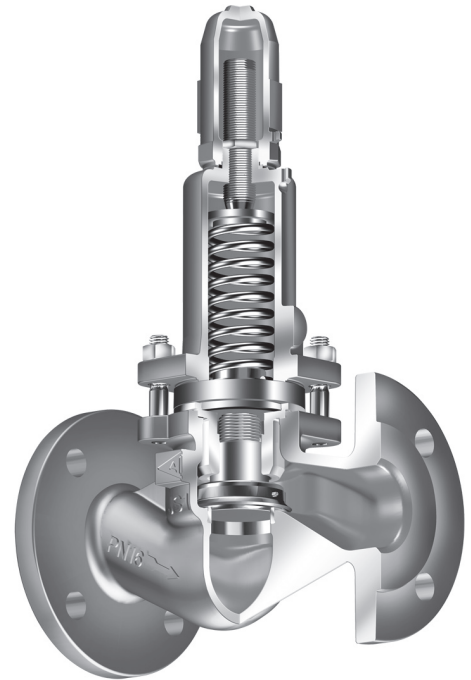

Fig. 753

Features:

- Spring loaded
- Standard bellows seal
- Compact design
- Regulating plug
- Shaft plug guide
- Pressure range:
 - 0,5 - 1,5 bar
 - 1,0 - 3,0 bar
 - 2,0 - 5,0 bar
 - 4,0 - 10,0 bar
- Exact and easy adjustment
- Proportional flow characteristic
- Maintenance-free

Pressure regulating valve - straight through with flanges - spring loaded (Grey cast iron, SG iron, Cast steel, Stainless steel)

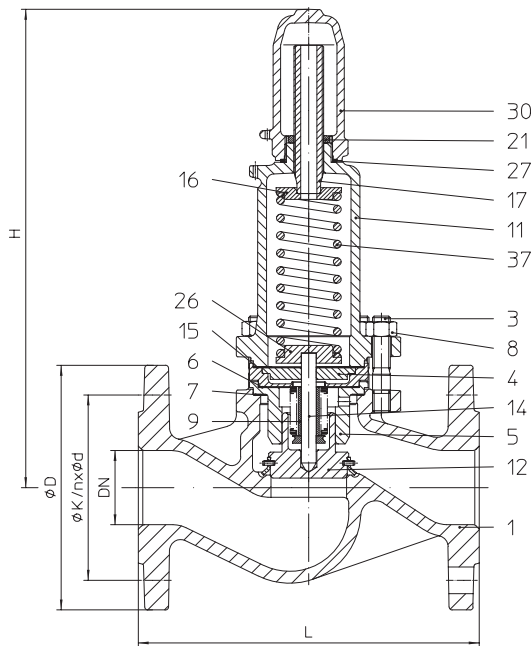

Figure	Nominal pressure	Material	Nominal diameter
12.753	PN 16	EN-JL1040	DN15-100
22.753	PN 16	EN-JS1049	DN15-100
32.753	PN 16	1.0619+N	DN15-100
52.753	PN 16	1.4408	DN15-100

Test:	• TA - Air TÜV-Test-No. 922-9241371
-------	-------------------------------------

Parts						
Pos.	Sp.p.	Description	Fig. 12.753	Fig. 22.753	Fig. 32.753	Fig. 52.753
1		Body	EN-JL1040, EN-GJL-250	EN-JS1049, EN-GJS-400-18U-LT	GP240GH+N, 1.0619+N	GX5CrNiMo19-11-2, 1.4408
1.2		Seat	X20Cr13+QZ, 1.4021+QT			--
3		Stud	25CrMo4, 1.7218			A4-70
4		Stem guide	X20Cr13+QZ, 1.4021+QT			
5		Guide housing	X20Cr13+QZ, 1.4021+QT			X6CrNiMoTi17-12-2, 1.4571
6	x	Gasket	Pure graphite (CrNi laminated with graphite)			
7	x	Gasket	Pure graphite (CrNi laminated with graphite)			
8		Hexagon nut	C35E, 1.1181			A4
9		Travel limiter ring	≥ DN40: X6CrNiMoTi17-12-2, 1.4571			
11		Bonnet	EN-JL1040, EN-GJL-250	EN-JS1049, EN-GJS-400-18U-LT		GX5CrNiMo19-11-2, 1.4408
12	x	Plug unit	X20Cr13+QZ, 1.4021+QT			X6CrNiMoTi17-12-2, 1.4571
14	x	Stem unit	X6CrNiMoTi17-12-2, 1.4571			
15	x	Gasket	Pure graphite (CrNi laminated with graphite)			
16		Spring plate (top)	DN15-20: X6CrNiMoTi17-12-2, ≥ DN25: 1.4571 S235JR, 1.0037			X6CrNiMoTi17-12-2, 1.4571
17		Adjusting screw	X20Cr13+QZ, 1.4021+QT			X6CrNiMoTi17-12-2, 1.4571
21		Lock nut	11SMn30+C, 1.0715+C			X6CrNiMoTi17-12-2, 1.4571
26		Spring plate (bottom)	DN15-20: X6CrNiMoTi17-12-2, ≥ DN25: 1.4571 S235JR, 1.0037			X6CrNiMoTi17-12-2, 1.4571
30		Cap, gastight	EN-JS1049, EN-GJS-400-18U-LT			GX5CrNiMo19-11-2, 1.4408
37	x	Compression spring	FDSiCr			
L Spare parts						

DN	15	20	25	32	40	50	65	80	100
----	----	----	----	----	----	----	----	----	-----

Face-to-face dimension FTF series 1 according to DIN EN 558		Standard-flange dimensions refer to page 4								
L	(mm)	130	150	160	180	200	230	290	310	350
H	(mm)	230	230	290	300	325	330	400	440	500

Dimensions										
Kvs-value	(m³/h)	2	2,5	3	5	10	20	22	29	45
Seat-Ø	(mm)	21	21	27	31	41	51	66	81	101
Travel	(mm)	2	2	2,5	2,5	4	5,5	7	8	10
Leakage rate		IV acc. to DIN EN 1349 (≤ 0,01% from the nominal flow)								

Weights										
12./22./32./52.753	(kg)	3,6	4,1	6,6	7,7	10,4	12,9	20,2	28,9	43,7

Information / restriction of technical rules need to be observed!

Operating and installation instructions can be downloaded at www.ari-armaturen.com.

ARI-Valves of EN-JL1040 are not allowed to be operated in systems acc. to TRD 110.

A production permission acc. to TRB 801 No. 45 is available (acc. to TRB 801 No. 45 EN-JL1040 is not allowed.)

The engineer, designing a system or a plant, is responsible for the selection of the correct valve.

Resistance and fitness must be verified (contact manufacturer for information, refer to Product overview and Resistance list).

Application

The pressure regulating valve PRESO is a spring loaded differential pressure-control valve. The main applications are:

- Pump protection: PRESO inserted parallel to the pump, this secures a minimum flow.
- Application in bypass lines from users, e.g. heat exchanger in thermal oil systems to sustain a minimum flow.
- Parallel to piping systems to avoid to higher differential pressures.
- Pressure maintaining valve to avoid the flashing in condensate systems.

Produktkey	Article code	Type	Material	Pressure	Connection	Nominal diameter	Feature1
28102000001	1275300652	ARI-PRESO	EN-JL1040	PN 16	flanged	DN 65	Kvs-value:22,0 Desig...
28102000007	2275300652	ARI-PRESO	EN-J51049	PN 16	flanged	DN 65	Kvs-value:22,0 Desig...
28102000011	3275300652	ARI-PRESO	1.0619+N	PN 16	flanged	DN 65	Kvs-value:22,0 Desig...
28102000016	5275300652	ARI-PRESO	1.4408	PN 16	flanged	DN 65	Kvs-value:22,0 Desig...

myValve - Valve Sizing-Program

Contents:

Module ARI-Pressure regulating valves PRESO-Calculation

- Sizing (calculation of valve-size with given temperature, flow, set pressure, opening pressure and set pressure)

Media:

Integrated media-data bank (more than 160 media) with conditions:

- Vapours / gases
- Steam (saturated and superheated)
- Liquids

Special features:

- Project administration of the calculation and product data incl. spare part drawings concerning to project and tag number
- Direct output or calculation and product data in PDF format
- Product data could be taken for a direct order
- SI- and ANSI-units with direct conversion to another data bank
- Settings with over pressure or absolute pressure
- All ARI Pressure regulating valves are integrated in a data bank
- Direct access concerning to the product on data sheets, operating instructions, pressure-temperature-diagram and spare part drawings
- Operation in company networks possible (no complex installations on individually PC's necessary)

System Requirements:

Windows operating systems, Linux, etc.

max. permissible back pressure p2		(Observe pressure-temperature-limits)								
DN		15	20	25	32	40	50	65	80	100
Setting range Δp_0 (bar)	Set point Δp_0 (bar)	max. permissible back pressure p2 (barg)								
0,5 - 1,5	0,5	4,5	4,5	6,9	6,4	6,6	9,5	4,9	6,7	5,9
	1	3	3	5,4	4,4	4,7	6,5	3,3	4,9	4,2
	1,5	1,5	1,5	3,9	2,4	2,7	3,5	1,7	3,1	2,5
1 - 3	1	8	8	10,6	11,2	9,9	14	7	7,7	6,8
	2	5	5	7,6	7,2	6	10,4	3,8	4,2	3,5
	3	2	2	4,6	3,2	2	6,8	0,5	0,6	0,1
2 - 5	2	8	8	12	12	12	12	11,3	10,8	10,2
	3	5,8	5,8	9,3	9,2	8,4	9,8	8,1	7,2	6,8
	4	3,7	3,7	6,6	6,5	4,9	7,7	4,8	3,7	3,5
	5	1,5	1,5	3,9	3,7	1,3	5,5	1,6	0,1	0,1
4 - 10	4	10	10	8	8	8	8	8	8	8
	6	7	7	5,7	5,7	5,7	5,7	5,7	5,7	5,7
	8	4	4	3,3	3,3	3,3	3,3	3,3	3,3	3,3
	10	1	1	1	1	1	1	1	1	1

Δp_0 = Differential pressure (Set pressure p_{10} – Back pressure p_2)

DN	15	20	25	32	40	50	65	80	100
----	----	----	----	----	----	----	----	----	-----

Standard-flange dimensions		Flanges acc. to DIN EN 1092-1/-2 (Flange holes / -thickness tolerances acc. to DIN 2533/2544/2545)								
----------------------------	--	--	--	--	--	--	--	--	--	--

PN16	ØD	(mm)	95	105	115	140	150	165	185	200	220
	ØK	(mm)	65	75	85	100	110	125	145	160	180
	n x Ød	(mm)	4x14	4x14	4x14	4x18	4x18	4x18	4x18 ¹⁾	8x18	8x18

¹⁾ auch with 8-loch Flanschbohrung acc. to DIN EN 1092-1/-2 möglich.

Pressure-temperature-ratings		Intermediate values for max. permissible operational pressures can be determined by linear interpolation of the given temperature / pressure chart.									
------------------------------	--	---	--	--	--	--	--	--	--	--	--

acc. to DIN EN 1092-2		-60°C to <-10°C ¹⁾	-10°C to 120°C	150°C	200°C	250°C	300°C	350°C	400°C	450°C
EN-JL1040	16	(bar)	--	16	14,4	12,8	11,2	9,6	--	--
EN-JS1049	16	(bar)	on request	16	15,5	14,7	13,9	12,8	11,2	--

acc. to manufacturers standard		-60°C to <-10°C ¹⁾	-10°C to 120°C	150°C	200°C	250°C	300°C	350°C	400°C	450°C
1.0619+N	25	(bar)	12	16	15,3	14	13	11	10,2	9,5

acc. to DIN EN 1092-1		-60°C to <-10°C ¹⁾	-10°C to 100°C	150°C	200°C	250°C	300°C	350°C	400°C	450°C
1.4408	16	(bar)	16	16	14,5	13,4	12,7	11,8	11,4	10,9

¹⁾ Studs and nuts made of A4-70 (at temperatures below -10°C)

Please indicate when ordering:

- Figure-No.
- Nominal diameter
- Nominal pressure
- Body material
- Plug design
- Kvs-value
- Setting range
- Special design / accessories

Example:

Figure 22.753; Nominal diameter DN50; Nominal pressure PN16; Body material EN-JS1049; metal seat; Kvs 20; Setting range 1 - 3 bar.



Technology for the Future.
GERMAN QUALITY VALVES

ARI-Armaturen Albert Richter GmbH & Co. KG, D-33756 Schloß Holte-Stukenbrock,
Tel. +49 52 07 / 994-0, Telefax +49 52 07 / 994-158 or 159 Internet: <http://www.ari-armaturen.com> E-mail: info.vertrieb@ari-armaturen.com