

Ultrasonic Level Measurement

prosonic M

FMU 40/41/42/43

Compact transmitters for non-contact level measurement of fluids, pastes and coarse bulk materials



Application

- Continuous, non-contact level measurement in fluids, pastes, sullages and coarse bulk materials
- Flow measurement in open channels and measuring weirs
- System integration via:
 - HART (standard), 4...20mA
 - PROFIBUS PA
 - Foundation Fieldbus
- Maximum measuring range:
 - FMU 40:
 - 5 m in fluids
 - 2 m in bulk materials
 - FMU 41:
 - 8 m in fluids
 - 3,5 m in bulk materials
 - FMU 42:
 - 10 m in fluids
 - 5 m in bulk materials
 - FMU 43:
 - 15 m in fluids
 - 7 m in bulk materials

Features and benefits

- Simple, menu-guided on-site operation with four-line plain text display
- Envelope curves on the on-site display for simple diagnosis
- Easy operation, diagnosis and measuring point documentation with the supplied ToF Tool operating program.
- Alignable IP 68 aluminium housing
- optional remote display and operation
- Installation possible from thread G 1½" or 1½ NPT upwards
- Integrated temperature sensor for time-of-flight correction. Accurate measurements, even for temperature changes
- Linearisation function (up to 32 points) for measured value output in any unit of length, volume or flow rate
- Non-contact measurement method, therefore almost independent of product properties

Endress + Hauser

The Power of Know How



Inhaltsverzeichnis

Function and system design	3	Process conditions	20
Measuring principle	3	Process temperature	20
Equipment architecture	4	Process pressure	20
Input	8	Mechanical construction	21
Measured variable	8	Design / dimensions	21
Measuring range	8	Weight	22
Operating frequency	9	Housing design	22
Output	10	Process connection, sealing material, sensor material	22
Output signal	10	Human interface	23
Signal on alarm	10	Display and operating elements	23
Load HART	10	On-site operation	24
Output damping	10	Remote operation	25
Linearisation	10	Certificates and Approvals	26
Auxiliary energy	11	CE mark	26
Terminal compartment	11	Ex approval	26
Fieldbus plug connector	11	External standards and guidelines	26
Terminal assignment	12	Ordering information	27
Supply voltage	13	Product structure FMU 40	27
Cable entry	13	Product structure FMU 41	28
Power consumption	13	Product structure FMU 42	29
Current consumption (2-wire-instruments)	13	Product structure FMU 43	30
HART ripple	13	Scope of delivery	30
Max. noise HART	13	Accessories	31
Galvanic isolation	14	Weather protection cover	31
Performance characteristics	14	Installation bracket for FMU 40/41	31
Reaction time	14	Adapter flange for FMU 40 / FMU 41	32
Reference operating conditions	14	Cantilever	33
Measured value resolution	14	Mounting Frame for Cantilever	34
Pulse frequency	14	Wall Bracket for Cantilever	34
Measuring error	14	Commubox FXA 191	34
Installation conditions	15	Service Interface FXA 193	35
Installation variants FMU 40, FMU 41	15	Remote display FHX 40	35
Installation variants FMU 42	15	Supplementary documentation	37
Installation variants FMU 43	16	System Information	37
Installation conditions for level measurements	16	Operating manual	37
Installation in narrow shafts	17	Description of device functions	37
Installation conditions for flow measurements	17	Short instructions	37
Blocking distance, nozzle installation	19	Safety Instructions	37
Ambient conditions	20	Control drawings Installation drawings	38
Ambient temperature	20		
Storage temperature	20		
Resistance to alternating temperature cycles	20		
Climate class	20		
Ingress protection	20		
Vibration resistance	20		
Electromagnetic compatibility (EMC)	20		

Function and system design

Measuring principle

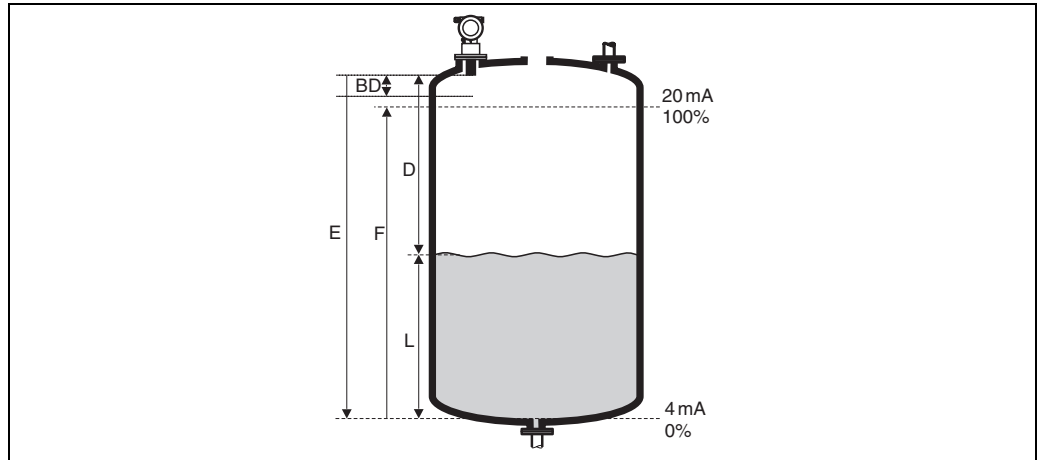

E: Empty distance; **F:** Span (full distance); **D:** Distance from sensor membrane - product surface; **L:** Level; **BD:** Blocking distance

Sensor	BD	Max. range fluids	Max. range bulk materials
FMU 40	0.25 m	5 m	2 m
FMU 41	0.35 m	8 m	3.5 m
FMU 42	0.4 m	10 m	5 m
FMU 43	0.6 m	15 m	7 m

Time-of-flight method

The sensor of the Prosonic M transmits ultrasonic pulses in the direction of the product surface. There, they are reflected back and received by the sensor. The Prosonic M measures the time t between pulse transmission and reception. The instrument uses the time t (and the velocity of sound c) to calculate the distance D between the sensor membrane and the product surface:

$$D = c \cdot t/2$$

As the device knows the empty distance E from a user entry, it can calculate the level as follows:

$$L = E - D$$

An integrated temperature sensor compensates for changes in the velocity of sound caused by temperature changes.

Interference echo suppression

The interference echo suppression feature on the Prosonic M ensures that interference echos (e.g. from edges, welded joints and installations) are not interpreted as a level echo.

Calibration

Enter the empty distance E and the span F to calibrate the device.

Blocking distance

Span F may not extend into the blocking distance BD . Level echos from the blocking distance cannot be evaluated due to the transient characteristics of the sensor.

Equipment architecture

4...20 mA output with HART protocol

The complete measuring system consists of:

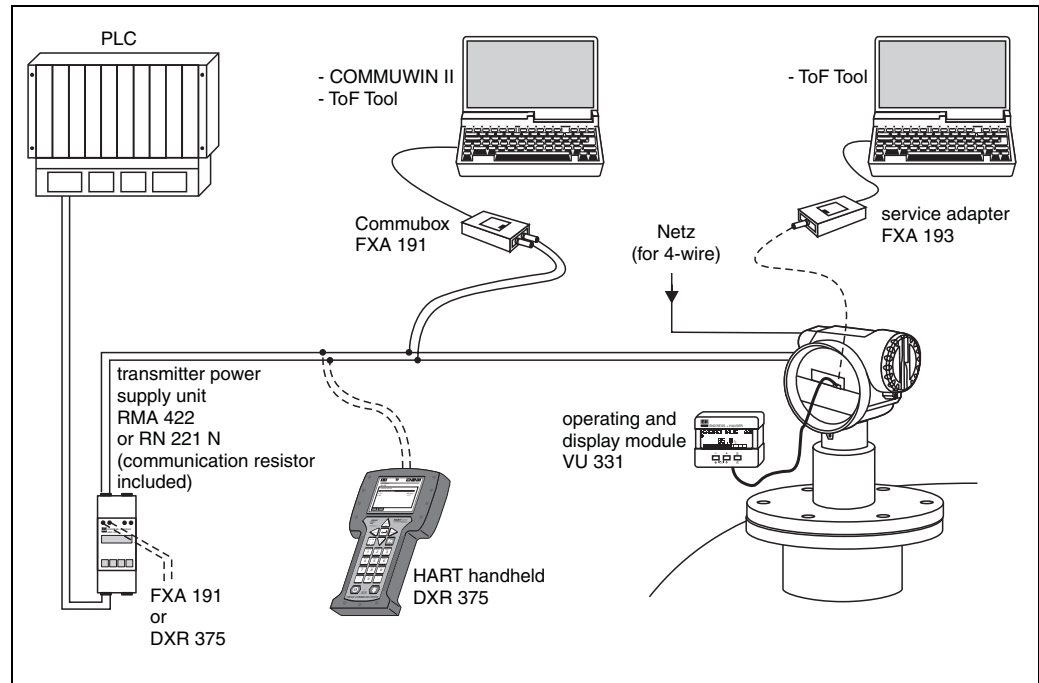

L00-FMxxxxx-14-00-06-en-007

If the HART communication resistor is not built into the supply unit, it is necessary to insert a communication resistor of 250Ω into the 2-wire line.

On-site operation

- with display and operating module VU 331
- with a Personal Computer, FXA 193 and the operating software ToF Tool

Remote operation

- with HART handheld terminal DXR 375
- with a Personal Computer, Commubox FXA 191 and the operating software COMMUWIN II respectively ToF Tool.

System integration using PROFIBUS PA

A maximum of 32 transmitters (8 if mounted in an explosion hazardous location EEx ia IIC according to FISCO-model) can be connected to the bus. The segment coupler provides the operating voltage to the bus. Both on-site as well as remote operation are possible.

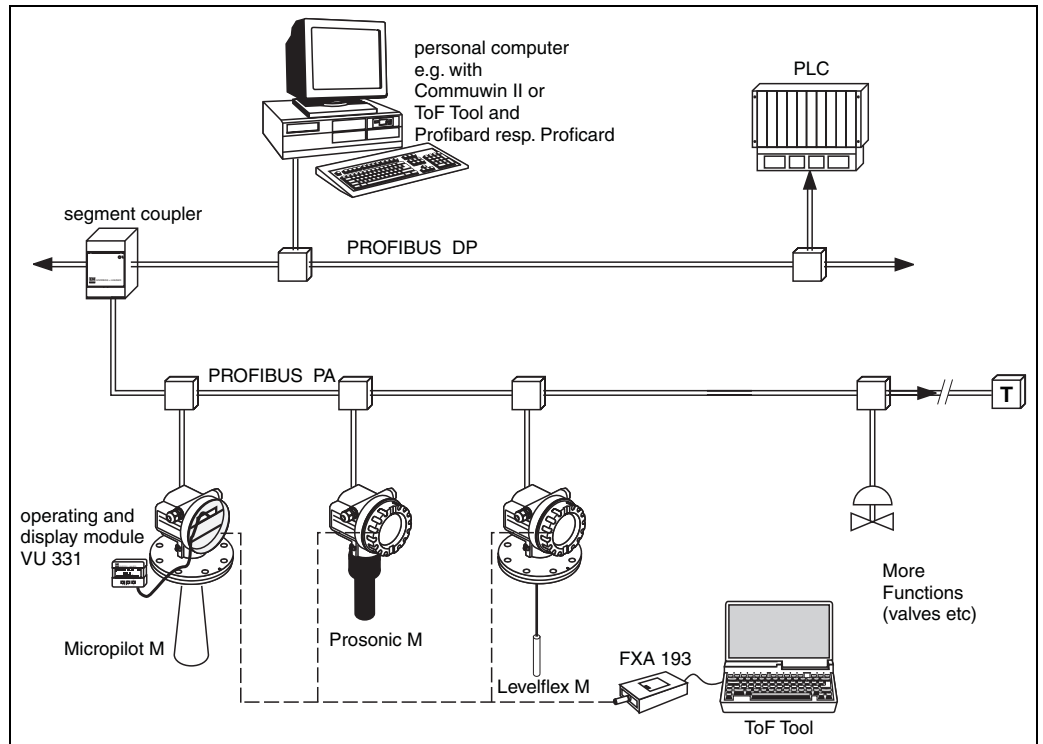

L00-FMxxXXXX-14-00-06-en-001

System integration using Foundation Fieldbus (FF)

A maximum of 32 transmitters (standard or EEx d) can be connected to the bus. For protection class EEx ia: the maximum number of transmitters depends on the established rules and standards for intrinsically safe circuits (EN 60070-14) and proof of intrinsic safety. Both on-site and remote operation are possible.

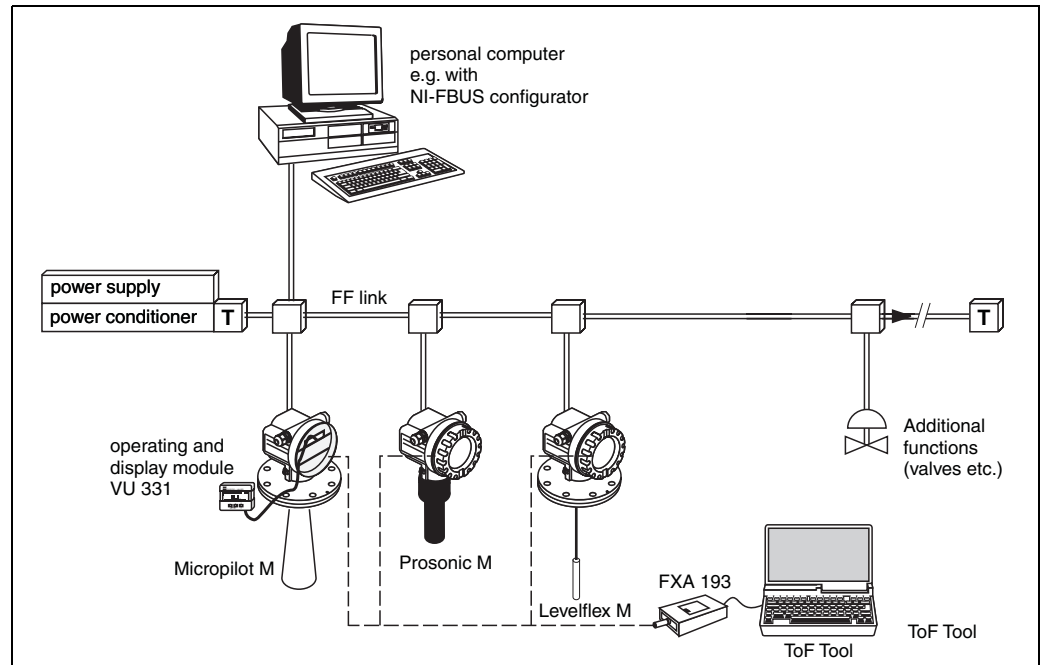

System integration using Endress+Hauser Rackbus

You can interconnect a maximum of 64 devices with HART protocol to a Rackbus. Use an FXN 672 interface module for each device. You can integrate this bus into a higher-level bus by using a ZA gateway. Gateways are available for MODBUS, FIP, PROFIBUS, INTERBUS etc. Both on-site and remote operation are possible.

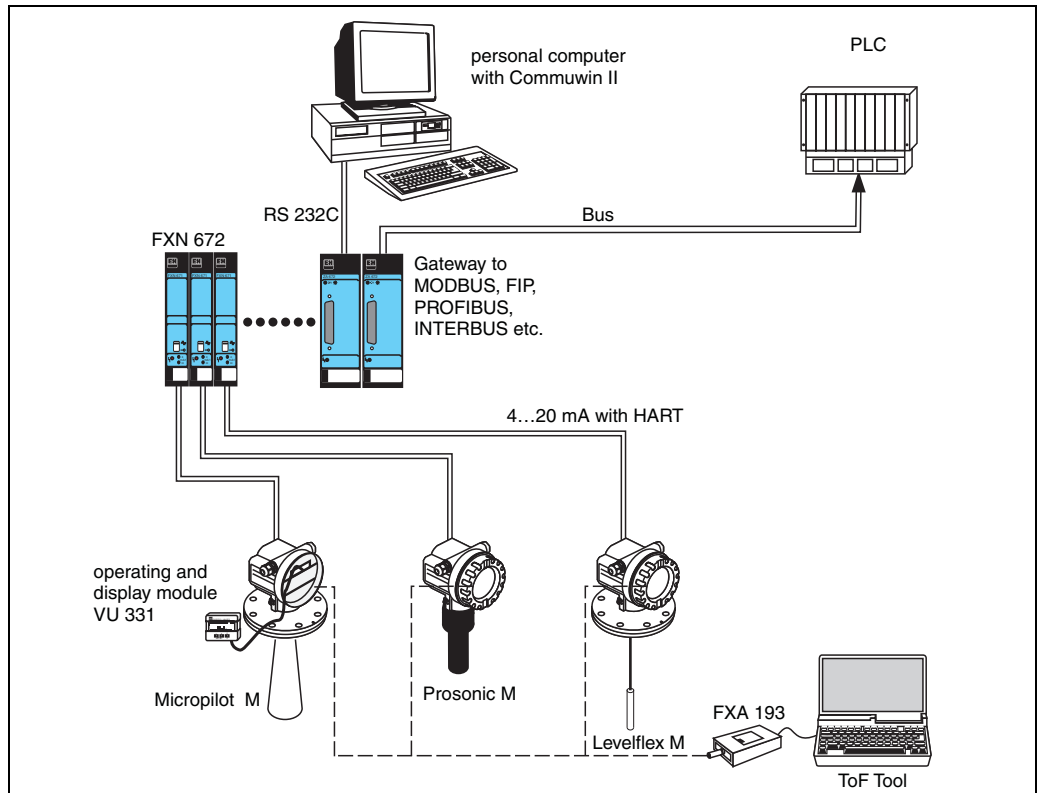

L00-FMxxXXXX-14-00-06-en-006

Input

Measured variable

The distance D between the sensor membrane and the product surface is measured.

Using the linearisation function, the device uses D to calculate:

- level L in any units
- volume V in any units
- flow Q across measuring weirs or open channels in any units

Measuring range

The measuring range is limited by the range of a sensor. The sensor range is, in turn, dependent on the operating conditions. To estimate the actual range, proceed as follows (see also the calculation example in the diagram):

1. Determine which of the influences shown in the following table are appropriate for your process.
2. Add the corresponding attenuation values.
3. From the total attenuation, use the diagram to calculate the range.

Fluid surface	Attenuation
Calm	0 dB
Waves	5 ... 10 dB
Strong turbulence (e.g. stirrers)	10 ... 20 dB
Foaming	Ask E+H

Bulk material surface	Attenuation
Hard, rough (e.g. rubble)	40 dB
Soft (e.g. peat, dust-covered clinker)	40 ... 60 dB

Dust	Attenuation
No dust formation	0 dB
Little dust formation	5 dB
Heavy dust formation	5 ... 20 dB

Filling curtain in detection range	Attenuation
None	0 dB
Small quantities	5 ... 10 dB
Large quantities	10 ... 40 dB

Temperature difference between sensor and product surface	Attenuation
to 20 °C	0 dB
to 40 °C	5 ... 10 dB
to 80 °C	10 ... 20 dB

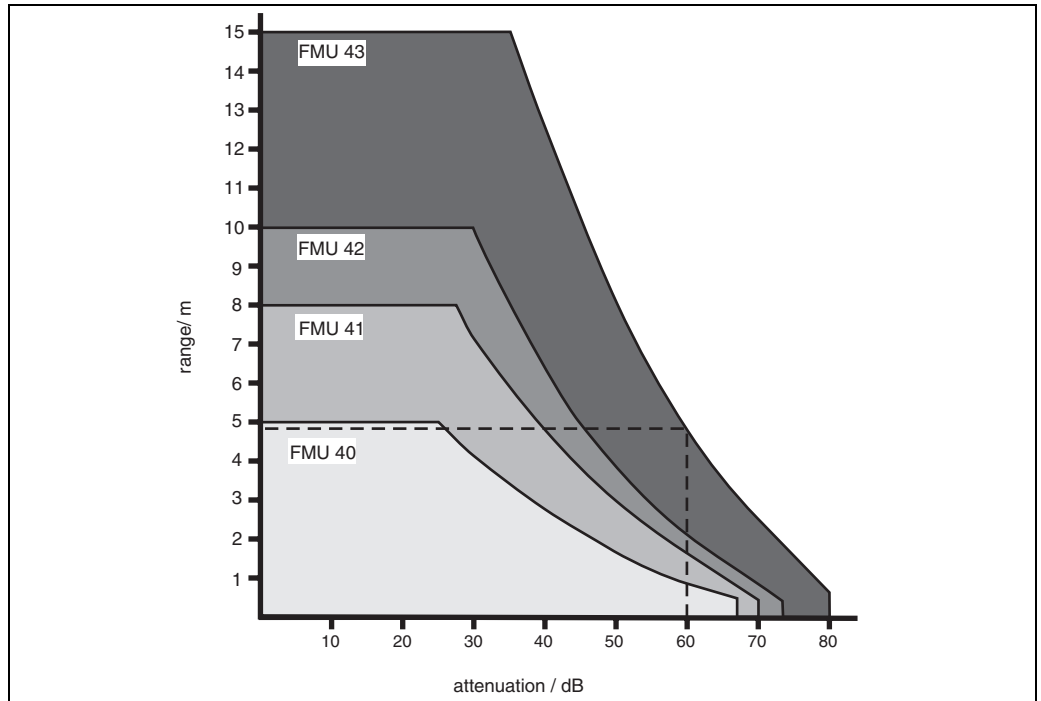

L00-FMU4xxxx-05-00-00-en-002

Example (for FMU 43)

- Dust-covered rubble ca. 50 dB
 - Medium dust development ca. 10 dB
 - No filling curtain in detection range 0 dB
 - Temperature diff. < 20°C 0 dB
- $\frac{\quad}{\text{approx. 60 dB}} \Rightarrow \text{range approx. 5 m}$

Operating frequency

Sensor	Operating frequency
FMU 40	approx. 70 kHz
FMU 41	approx. 50 kHz
FMU 42	approx. 42 kHz
FMU 43	approx. 35 kHz

Output

Output signal

- 4...20 mA with HART protocol
- PROFIBUS PA
- Foundation Fieldbus (FF)

Signal on alarm

- Error information can be accessed via the following interfaces:
- On-site display (error symbol, error code and plain text description)
 - Current output (configurable)
 - Digital interface

Load HART

Minimum load for HART communication: 250 Ω

Output damping

Freely selectable, 0 ... 255 s

Linearisation

The linearisation function of the Prosonic M allows conversion of the measured value into any unit of length or volume. In open channels or measuring weirs, it is also possible to linearise the flow. Linearisation tables for calculating volume in horizontal cylindrical tanks are preprogrammed. You can also enter any number of other tables containing up to 32 value pairs either manually or semi-automatically (by filling the vessel under controlled conditions). You can use the supplied ToF Tool operating program to calculate the table automatically for any tank form and then enter it in the device. Flow curves for open channels can be calculated and entered into the instrument by the ToT Tool as well.

Auxiliary energy

Terminal compartment

In the F12 housing, the terminals are located underneath the housing cover. In the T12 housing, they are under the cover of the separate terminal compartment.

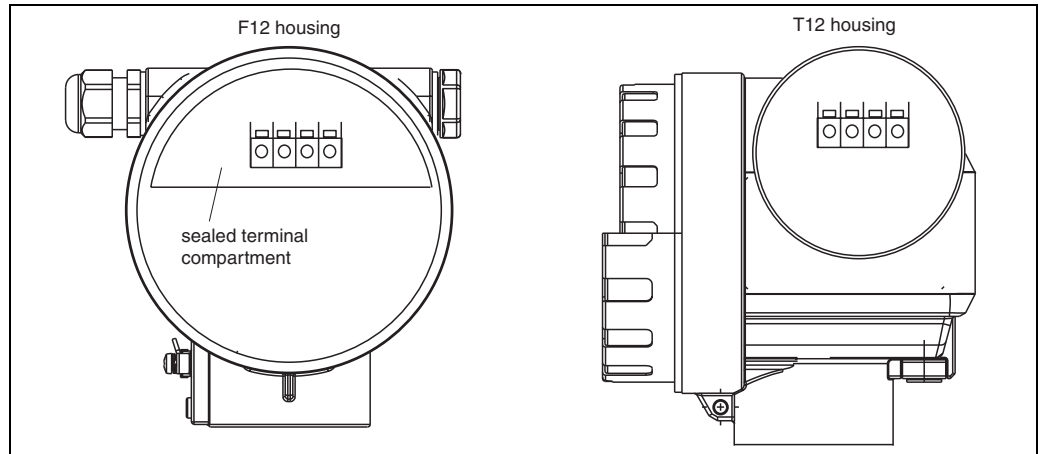

L00-FMR2xxxx-04-00-00-en-001

Fieldbus plug connector

- For the PROFIBUS-PA version, there is a version available with an M12 plug connector.
- For the Foundation Fieldbus variant, there is a version available with a 7/8" plug connector.

These versions are supplied fully-wired.

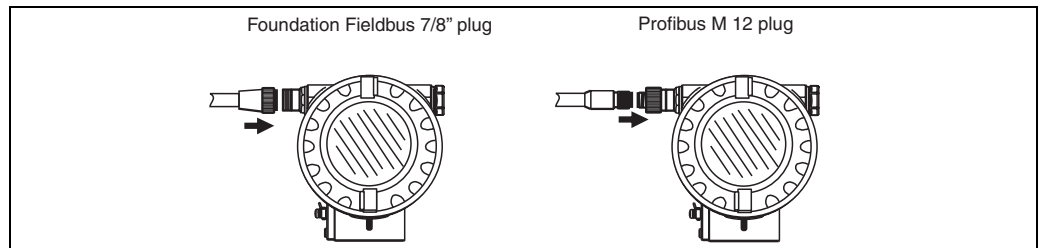

L00-FMxxxxxx-04-00-00-en-003

Terminal assignment

4 ... 20 mA with HART, 2-wire

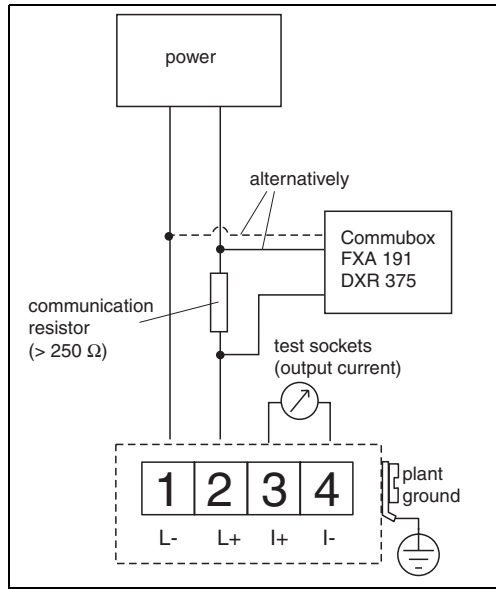

L00-FMRxxxxx-04-00-00-en-004

4 ... 20 mA with HART, active, 4-wire

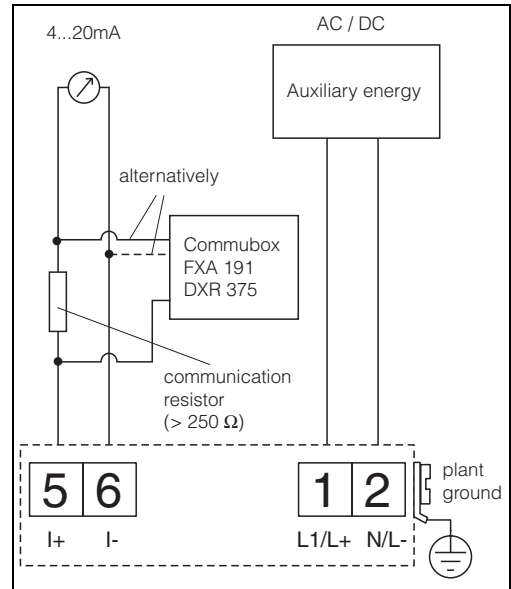

L00-FMRxxxxx-04-00-00-en-001

- Connect the connecting line to the screw terminals (line cross-sections of 0.5 ... 2.5mm) in the terminal compartment.
- Use 2-wire twisted pair cable with screen for the connection.
- Protective circuitry against reverse polarity, RFI and over-voltage peaks is built into the device (see also Technical Information TI 241F/00/en "EMC Test Procedures")

PROFIBUS PA

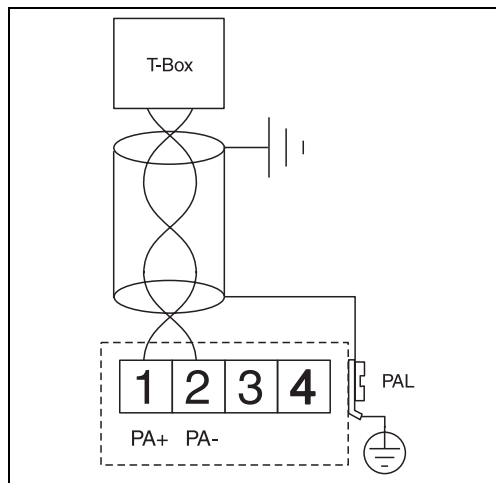

L00-FMR2xxxx-04-00-00-de-003

Foundation Fieldbus

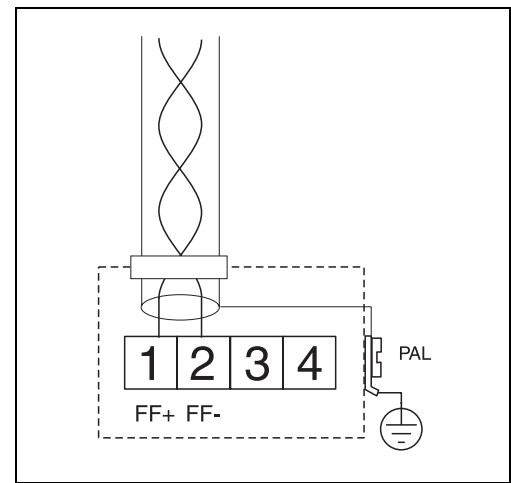

L00-FMR2xxxx-04-00-00-de-007

The digital communication signal is transmitted to the bus via a 2-wire connection. The bus also provides the auxiliary energy. Please use 2-wire twisted pair cable with screen.

Refer to the following operating manuals for information on cable types, and how to set up and ground the network:

- BA 198F/00/de „PROFIBIS -DP/-PA, Guidelines for planning and commissioning“
- BA 013S/04/en „Foundation Fieldbus, Installation and Commissioning Guidelines“

Supply voltage

HART, 2-wire

The following values are the voltages across the terminals directly at the instrument:

Version		Current consumption	Terminal voltage minimum	Terminal voltage maximum
2-wire HART	Standard	4 mA	14 V	36 V
		20 mA	8 V	36 V
	EEx ia	4 mA	14 V	30 V
		20 mA	8 V	30 V
	EEx d	4 mA	14 V	30 V
		20 mA	11 V	30 V
Fixed current, adjustable, e.g. for solar power operation (measured value via HART)	Standard	11 mA	10 V	36 V
	EEx ia	11 mA	10 V	30 V
Fixed current for HART multidrop mode	Standard	4 mA ¹	14 V	36 V
	EEx ia	4 mA ¹	14 V	30 V

1) Start-up current 11 mA

HART, 4-wire, active

Version	Voltage	max. load
DC	10,5 ... 32 V	600 Ω
AC 50/60 Hz	90 ... 253 V	600 Ω

Cable entry

- Cable gland: M20x1.5 (recommended cable diameter 6 ... 10 mm)
- Cable entry G ½ or ½ NPT
- PROFIBUS-PA M12 plug
- Fieldbus Foundation 7/8" plug

Power consumption

Version	Power consumption
2-wire	51 mW ... 800 mW
4-wire AC	max. 4VA
4-wire DC; FMU 40/41	330 mW ... 830 mW
4-wire DC; FMU 42/43	600 mW ... 1 W

Current consumption (2-wire-instruments)

Communication	Current consumption
HART	3,6 ... 22 mA
PROFIBUS PA	max. 13 mA
Foundation Fieldbus	max. 15 mA

HART ripple

47... 125 Hz: Vpp = 200 mV (measured at 500 Ω)

Max. noise HART

500 Hz... 10 kHz: Vrms = 2.2 mV (measured at 500 Ω)

Galvanic isolation

With 4-wire devices, the evaluation electronics and mains voltage are galvanically isolated from each other.

Performance characteristics

Reaction time

The reaction time depends on the parameter settings (min. 0.5s for 4-wire devices, min. 2s for 2-wire devices).

Reference operating conditions

- Temperature = +20 °C
- Pressure = 1013 mbar abs.
- Humidity = 50 %
- Ideal reflective surface (e.g. calm, smooth fluid surface)
- No interference reflections within signal beam
- Set application parameters:
 - Tank shape = flat ceiling
 - Medium property = liquid
 - process conditions = calm surface

Measured value resolution

Sensor	Measured value resolution
FMU 40	1 mm
FMU 41	1 mm
FMU 42	2 mm
FMU 43	2 mm

Pulse frequency

- 2-wire devices: max. 0.5Hz
- 4-wire devices: max. 2Hz

The exact values are dependent on the type of device and supply voltage.

Measuring error

Typical specifications for reference operating conditions (include linearity, repeatability, and hysteresis):

Sensor	Measuring error
FMU 40	$\pm 2\text{ mm}$ or 0.2% of set measuring range ¹
FMU 41	$\pm 2\text{ mm}$ or 0,2% of set measuring range ¹
FMU 42	$\pm 4\text{ mm}$ or 0,2% of set measuring range ¹
FMU 43	$\pm 4\text{ mm}$ or 0,2% of set measuring range ¹

¹whichever is greater

Installation conditions

Installation variants FMU 40, FMU 41

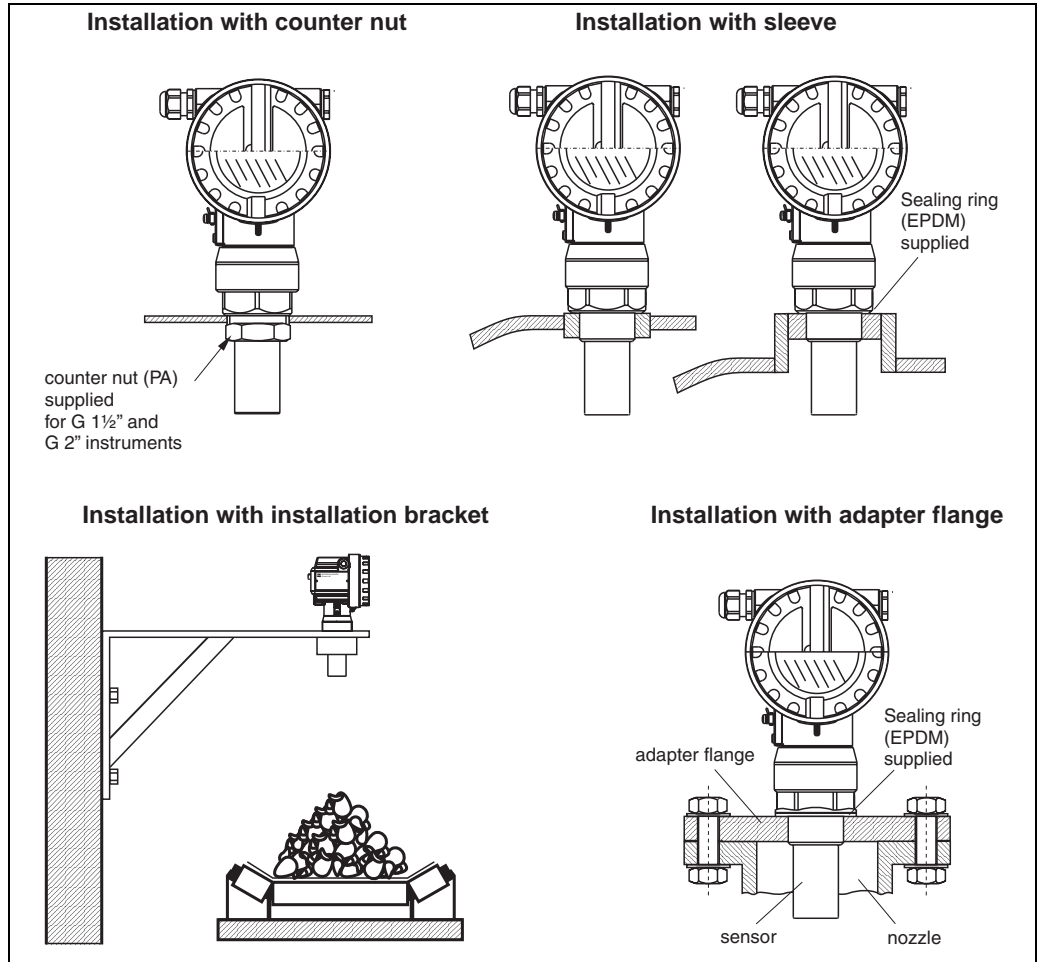

Installation variants FMU 42

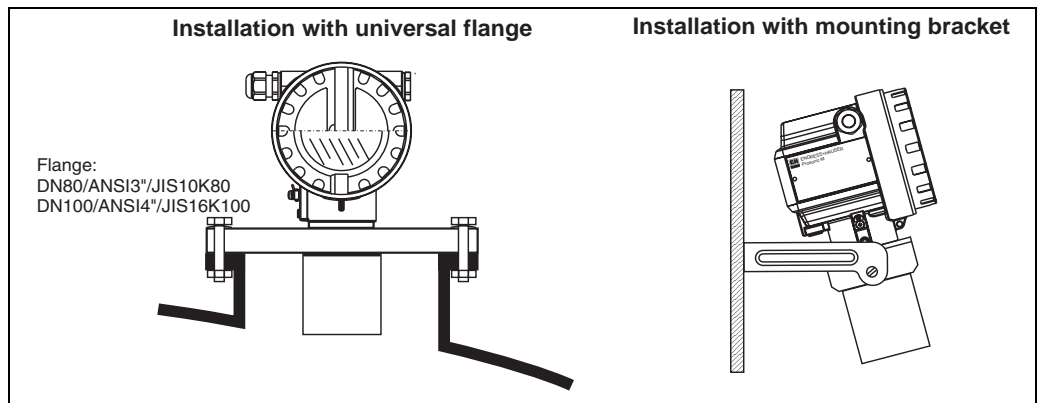

**Installation variants
FMU 43**

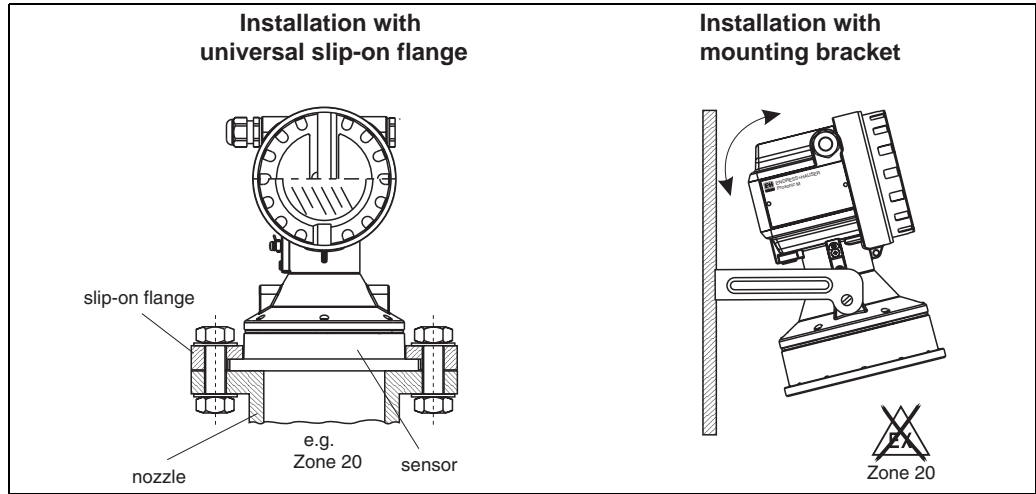

L00-FMU43xxxx-17-00-00-en-001

**Installation conditions for
level measurements**

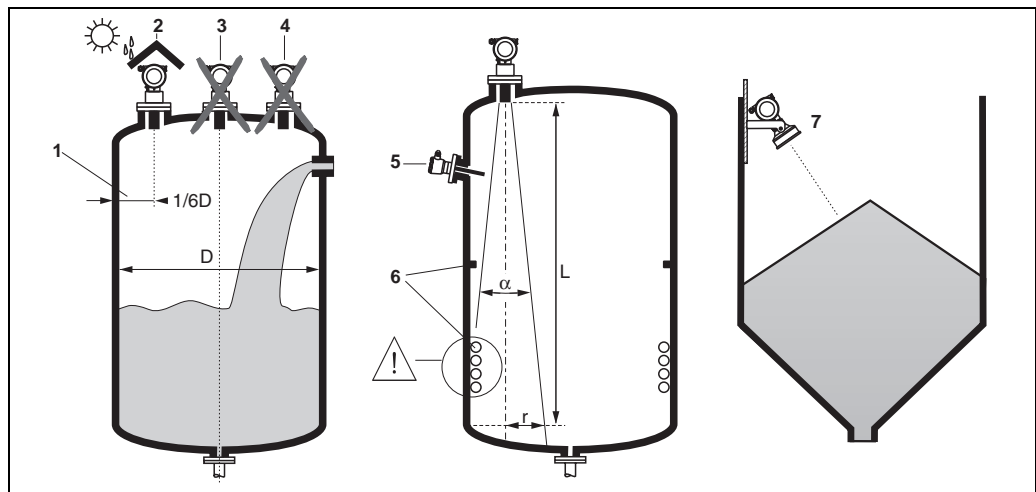

L00-FMU4xxxx-17-00-00-de-005

- Do not install the sensor in the middle of the tank (3). We recommend leaving a distance between the sensor and the tank wall (1) measuring 1/6 of the tank diameter.
- Use a protective cover, in order to protect the device from direct sun or rain (2).
- Avoid measurements through the filling curtain (4).
- Make sure that equipment (5) such as limit switches, temperature sensors, etc. are not located within the emitting angle α . In particular, symmetrical equipment (6) such as heating coils, baffles etc. can influence measurement.
- Align the sensor so that it is vertical to the product surface (7).
- Never install two ultrasonic measuring devices in a tank, as the two signals may affect each other.
- To estimate the transmitted echo beam and its detection range, use the 3 dB emitting angle α .

Sensor	α	L	r
FMU 40	11°	5 m	0,48 m
FMU 41	11°	8 m	0,77 m
FMU 42	11°	10 m	0,96 m
FMU 43	6°	15 m	0,79 m

Installation in narrow shafts

In narrow shafts with strong interference echoes, we recommend using an ultrasound guide pipe (e.g. PE or PVC wastewater pipe) with a minimum diameter of 100 mm. Make sure that the pipe is not soiled by accumulated dirt. If necessary, clean the pipe at regular intervals.

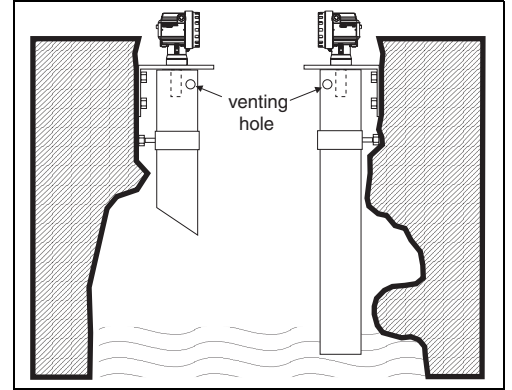

L00-FMU4xxxx-17-00-00-en-010

Installation conditions for flow measurements

- Install the Prosonic M at the inflow side, as close above the maximum water level H_{max} as possible, plus the blocking distance BD.
- Position the Prosonic M in the middle of the channel or weir.
- Align the sensor membrane parallel to the water surface.
- Keep to the installation distance of the channel or weir.
- You can enter the "Flow to Level" linearisation curve ("Q/h curve") using ToF Tool or manually via the on-site display.

Example: Khafagi-Venturi flume

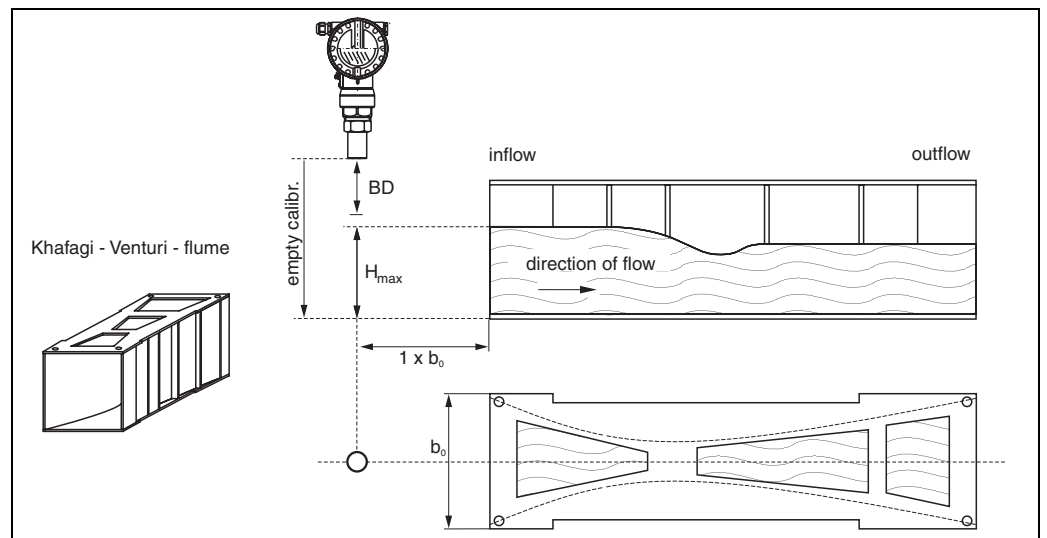

L00-FMU4xxxx-17-00-00-en-003

Example: Triangular weir

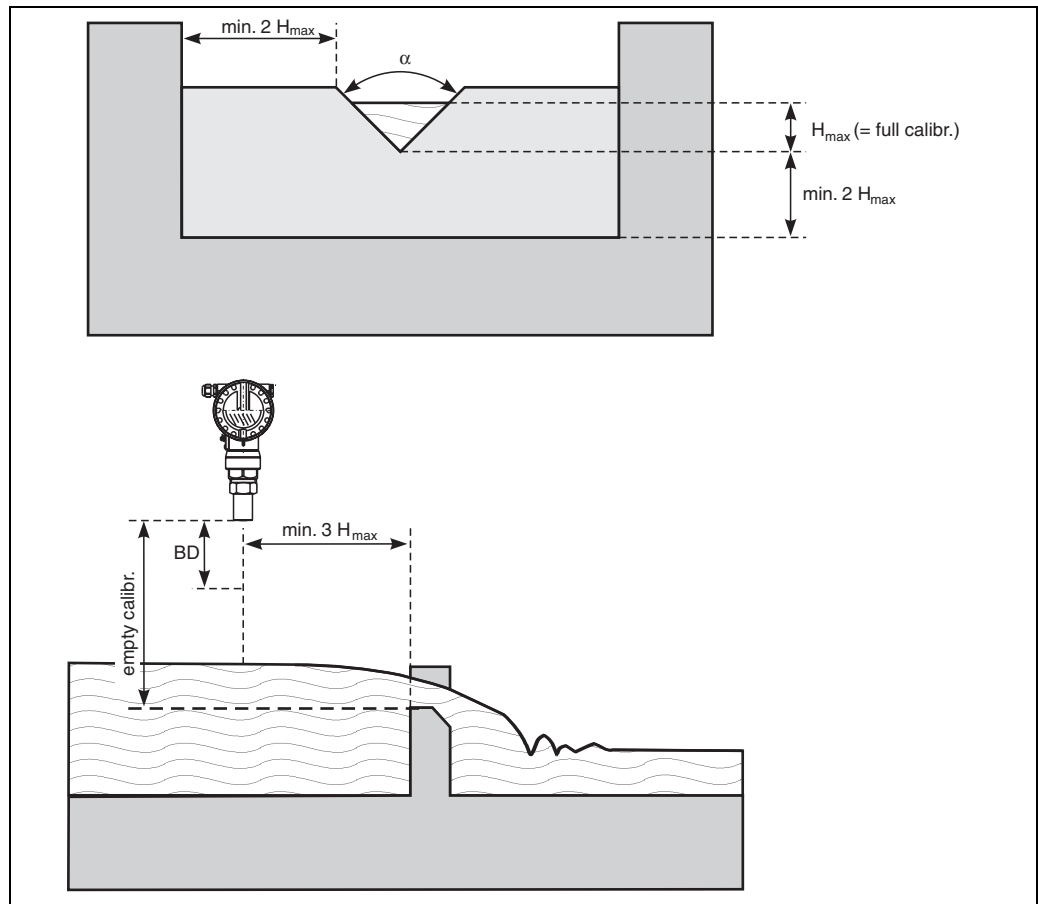

L00-FMU4xxxx-17-00-00-en-012

Blocking distance, nozzle installation

Install the Prosonic M at a height so that the blocking distance BD is not undershot, even at maximum fill level. Use a pipe nozzle if you cannot maintain the blocking distance in any other way. The interior of the nozzle must be smooth and may not contain any edges or welded joints. In particular, there should be no burr on the inside of the tank side nozzle end. Note the specified limits for nozzle diameter and length. To minimise disturbing factors, we recommend an angled socket edge (ideally 45°).

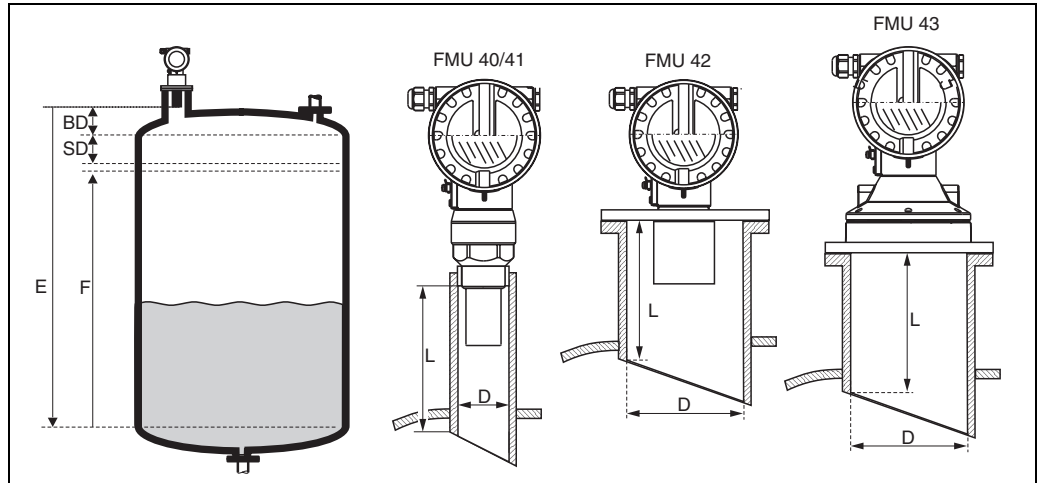

BD: blocking distance; **SD:** safety distance; **E:** empty calibration; **F:** full calibration (span); **D:** nozzle diameter; **L:** nozzle length

Sensor	BD	Max. range liquids	Max. range bulk materials	nozzle diameter	max. nozzle length
FMU 40	0.25 m	5 m	2 m	50 mm	ca. 80 mm
				80 mm	ca. 240 mm
				100 mm	ca. 300 mm
FMU 41	0.35 m	8 m	3.5 m	80 mm	ca. 240 mm
				100 mm	ca. 300 mm
FMU 42	0.4 m	10 m	5 m	min. 100 mm	ca. 300 mm
FMU 43	0.6 m	15 m	7 m		



Caution!
If the blocking distance is undershot, it may cause device malfunction.



Note!
In order to prevent the level from entering the blocking distance, you can specify a safety distance (SD). If the level is within this safety distance, the Prosonic M outputs a warning or alarm message.

Ambient conditions

Ambient temperature	-40 °C ... +80 °C The functionality of the LC display becomes restricted at $T_u < -20\text{ °C}$ and $T_u > +60\text{ °C}$. If the device is operated outdoors in strong sunlight, you should use a protective cover.
Storage temperature	-40 °C ... +80 °C
Resistance to alternating temperature cycles	to DIN EN 60068-2-14; Nb test : +80°C/-40°C, 1K/min, 100cycles
Climate class	DIN EN 60068-2-38 (Test Z/AD) DIN/IEC 68 T2-30Db
Ingress protection	<ul style="list-style-type: none"> • With closed housing, tested according to <ul style="list-style-type: none"> – IP 68, NEMA 6P (24h at 1.83m under water surface) – IP 66, NEMA 4x • With open housing: IP 20, NEMA 1 (also ingress protection of the display) <p> Caution! Degree of protection IP 68 NEMA 6P applies for M12 PROFIBUS-PA plugs only when plugged in.</p>
Vibration resistance	DIN EN 60068-2-64 / IEC 68-2-64: 20...2000 Hz, 1 (m/s ²)/Hz; 3 x 100 min
Electromagnetic compatibility (EMC)	<ul style="list-style-type: none"> • Interference emission to EN 61326, Equipment Class B • Interference immunity to EN 61326, Appendix A (Industrial) and NAMUR Recommendation NE 21 (EMC). • A standard installation cable is sufficient if only the analogue signal is used. Use a screened cable when working with a superimposed communication signal (HART).

Process conditions

Process temperature	-40°C ... +80°C A temperature sensor is integrated in the sensor for temperature-dependent time-of-flight correction.
Process pressure	<ul style="list-style-type: none"> • FMU 40/41: 3bar abs. • FMU 42/43: 2,5bar abs.

Mechanical construction

Design / dimensions

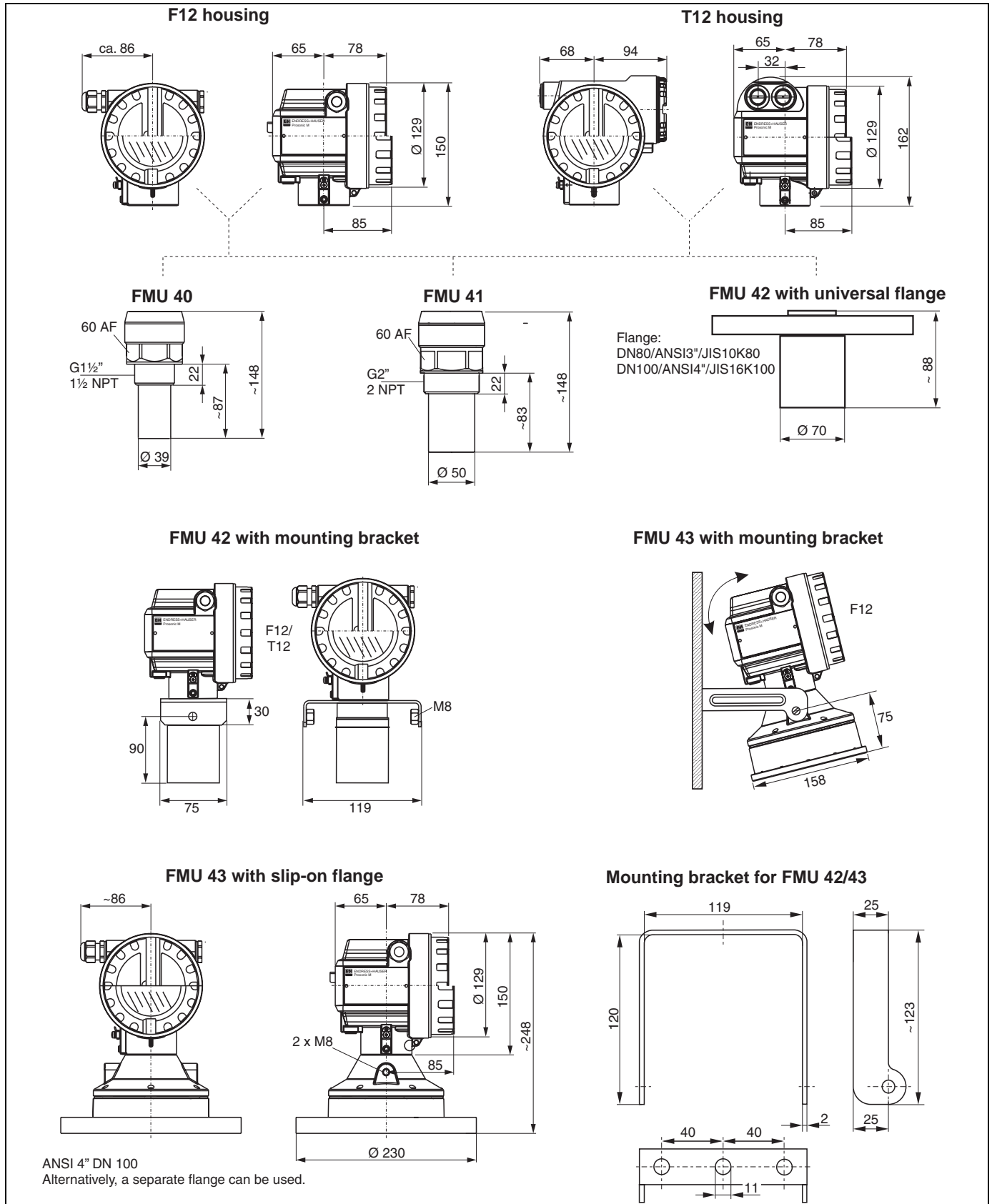

L00-FMU4xxxx-06-00-00-en-003

Weight

Sensor	Weight
FMU 40	approx. 2,5 kg
FMU 41	approx. 2,6 kg
FMU 42	approx. 3 kg
FMU 43	approx. 3,5 kg

Housing design**Types of housings**

- F12 housing with sealed terminal compartment for standard or EEx ia applications
- T12 housing with separate terminal compartment and explosionproof encapsulation

Material

Aluminium, seawater resistant, chromed, powder-coated

Cover

- Aluminium, for version without on-site display
- Inspection glass for version with on-site display. This version cannot be supplied together with the ATEX II 1/2 D certificate.

Process connection, sealing material, sensor material

Sensor	Process connection	Material in contact with process
FMU 40	<ul style="list-style-type: none"> • Thread G 1½" • Thread NPT 1½" - 11.5 	Sensor: PVDF Seal: EPDM
FMU 41	<ul style="list-style-type: none"> • Thread 2" • Thread NPT 2" - 11,5 	Sensor: PVDF Seal: EPDM
FMU 42	<ul style="list-style-type: none"> • Universal flange DN 80 / ANSI 3" / JIS10K80 • Universal flange DN 100 / ANSI 4" / JIS16K100 • Mounting bracket 	Sensor: PVDF Seal: VITON or EPDM Flange: PP, PVDF or SS 316
FMU 43	<ul style="list-style-type: none"> • Universal flange DN 80 / ANSI 3" / JIS10K80 • Universal flange DN 100 / ANSI 4" / JIS16K100 • Mounting bracket 	Sensor: UP and SS 316Ti Seal: EPDM



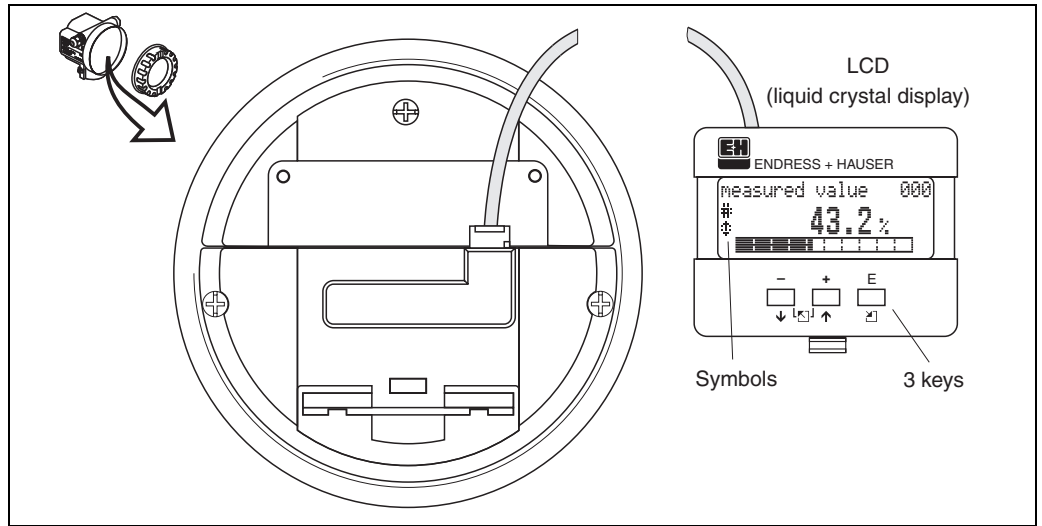

Human interface

Display and operating elements















The LCD module VU 331 for display and operation is located beneath the housing cover. The measured value is legible through the glass in the cover. Open the cover to operate the device.



L00-FMxxxxxx-07-00-00-en-001

Symbol in display				
	continuous	flashing		
Meaning	Alarm	Warning	Communication	Security Locking

Function of the keys

Key(s)	Meaning
 or 	Navigate upwards in the selection list Edit numeric value within a function
 or 	Navigate downwards in the selection list Edit numeric value within a function
  or 	Navigate to the left within a function group
	Navigate to the right within a function group, confirmation.
 and  or  and 	Contrast settings of the LCD
 and  and 	Hardware lock / unlock After a hardware lock, an operation of the instrument via display or communication is not possible! The hardware can only be unlocked via the display. An unlock parameter must be entered to do so.

On-site operation

Operation with VU 331

The LC-Display VU 331 allows configuration via 3 keys directly at the instrument. All device functions can be set through a menu system. The menu consists of function groups and functions. Within a function, application parameters can be read or adjusted. The user is guided through a complete configuration procedure.

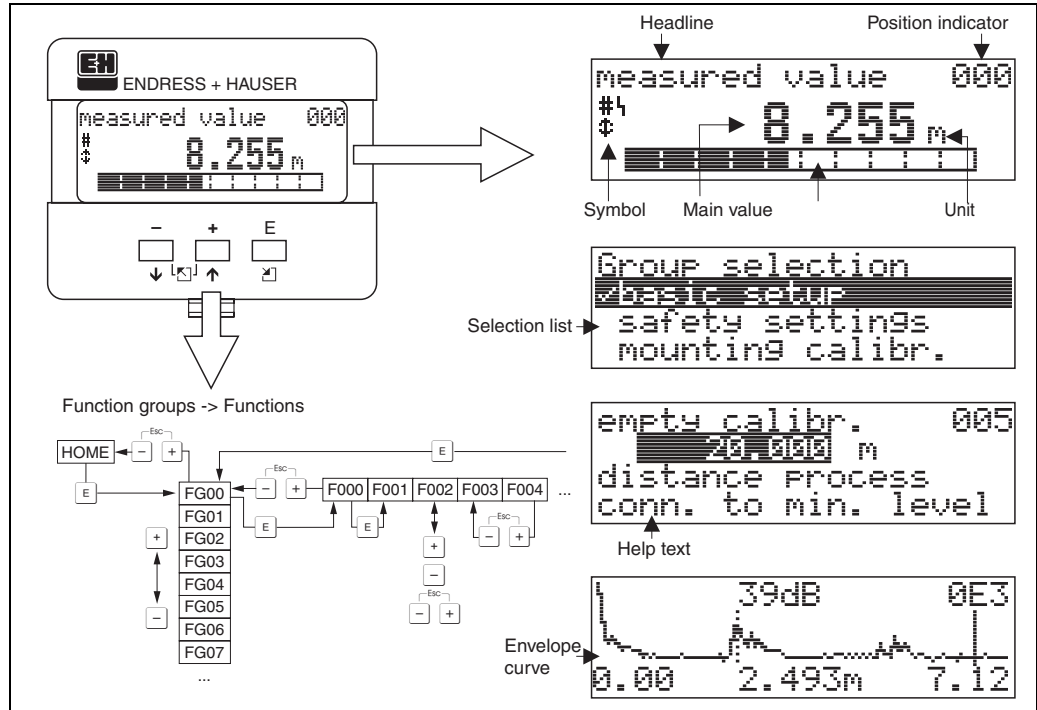

L00-FMU4xxxx-07-00-00-en-004

Operation with the handheld terminal DXR 375

On devices with HART communication, you can also access the menu using the handheld terminal DXR 375.

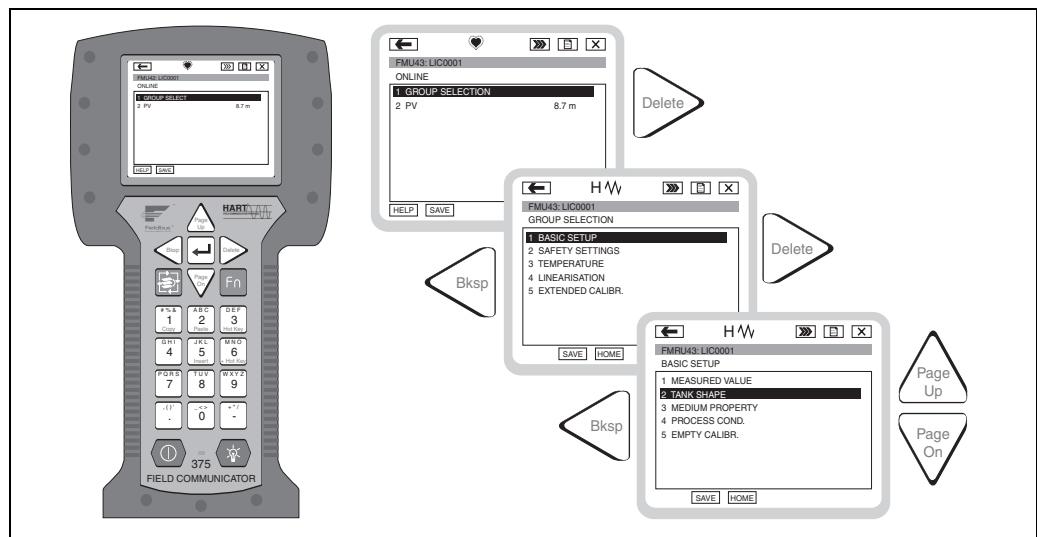

L00-FMU4xxxx-07-00-00-de-005

Remote operation

Operation with ToF Tool

The ToF Tool is a graphical operation software for instruments from Endress+Hauser. It is used to support commissioning, securing of data, signal analysis and documentation of the instruments. It is compatible with the following operating systems: Win95, Win98, WinNT4.0 and Win2000.

The ToF Tool supports the following functions:

- Online configuration of transmitters
- Signal analysis via envelope curve
- Loading and saving of instrument data (Upload/Download)
- Documentation of measuring point

Connection options

- HART with Commubox FXA 191 (available as accessory)
- PROFIBUS PA
- Service-interface with adapter FXA 193 (available as accessory)

Menu-guided commissioning:

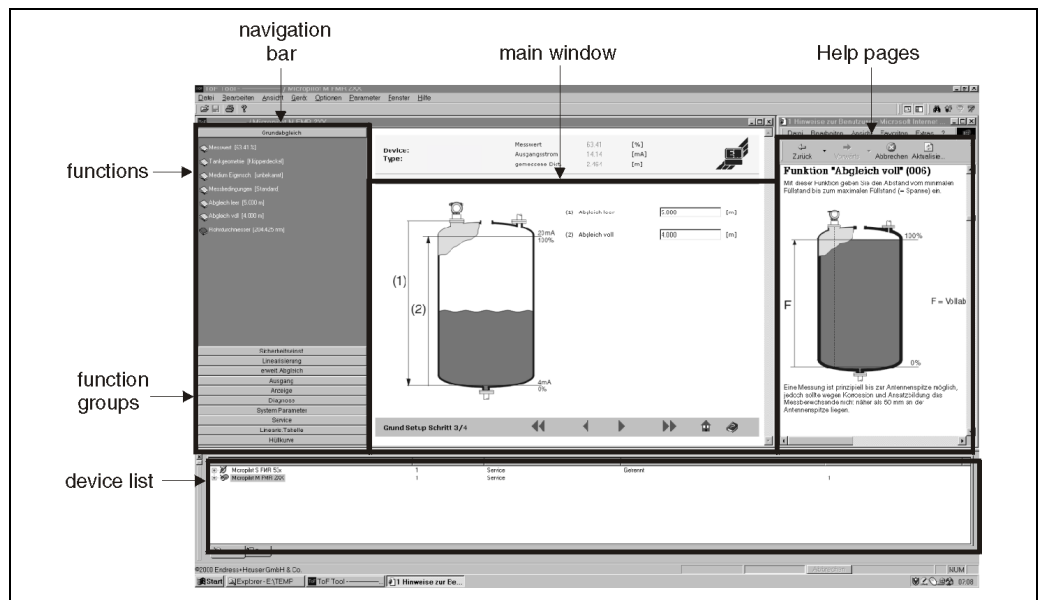

L00-FMU4xxxx-19-00-00-en-003

Signal analysis via envelope curve:

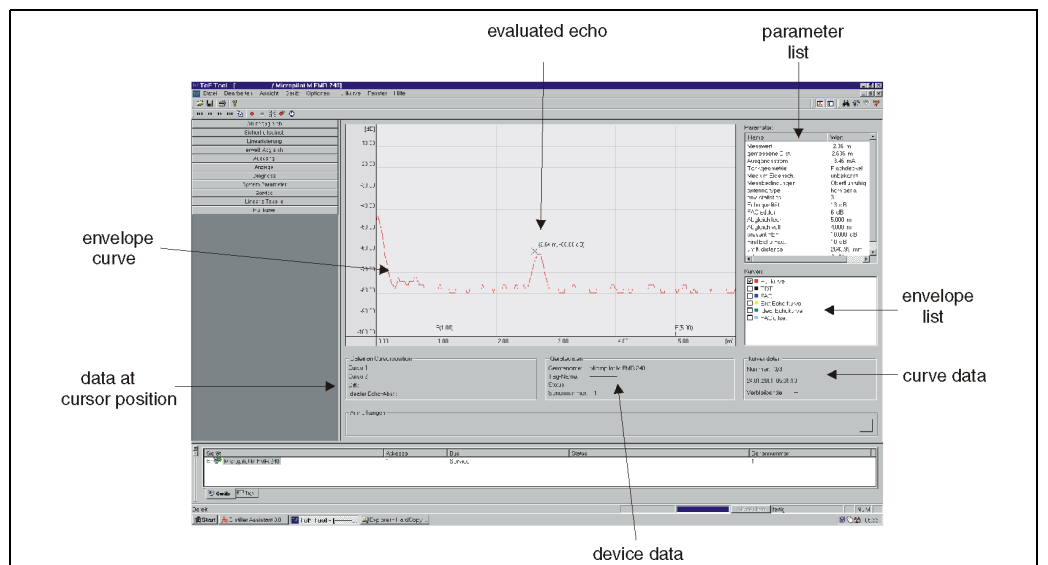

L00-FMU4xxxx-19-00-00-en-004

Operation with Commuwin II (for communication variants HART or PROFIBUS-PA)

Commuwin II is an operating software with graphical support (MS Windows) for intelligent transmitters with the communication protocols Rackbus, Rackbus RS-485, HART and PROFIBUS-PA.

Commuwin II supports the following functions:

- Online configuration of transmitters
- Loading and saving of instrument data (Upload/Download)
- Orderly visualisation of measured values and limit values
- Display and recording of measured values with a line recorder

It is not possible to display envelope curves with Commuwin II. To display them, please use the ToF Tool program supplied.

Connections:

- HART with Commubox FXA 191 (available as accessory)
- PROFIBUS PA

Operation with NI-FBUS Configurator (only Foundation Fieldbus)

The NI-FBUS Configurator is an easy-to-use graphical environment for creating linkages, loops, and a schedule based on the fieldbus concepts.

You can use the NI-FBUS Configurator to configure a fieldbus network as follows:

- Set block and device tags
- Set device addresses
- Create and edit function block control strategies (function block applications)
- Configure vendor-defined function and transducer blocks
- Create and edit schedules
- Read and write to function block control strategies (function block applications)
- Invoke Device Description (DD) methods
- Display DD menus
- Download a configuration
- Verify a configuration and compare it to a saved configuration
- Monitor a downloaded configuration
- Replace devices
- Save and print a configuration

Certificates and Approvals

CE mark

The measuring system meets the legal requirements of the EC-guidelines. Endress+Hauser confirms the instrument passing the required tests by attaching the CE-mark.

Ex approval

The available certificates are listed in the ordering information. Note the associated safety instructions (XA) and control or installation drawings (ZD).

External standards and guidelines

EN 60529

Protection class of housing (IP-code)

EN 61326

Electromagnetic compatibility (EMC requirements)

NAMUR

Standards committee for measurement and control in the chemical industry

Ordering information

Product structure FMU 40

					Certificates	
	A					Variant for non-hazardous area
	1					ATEX II 1/2 G or II 2 G; EEX ia IIC T6
	4					ATEX II 1/2 G or II 2 G; EEX d [ia] IIC T6
	S					FM IS Cl. I,II,III Div. 1 Gr. A-G / NI Cl. I Div. 2
	T					FM XP Cl. I,II,III Div. 1 Gr. A-G
	U					CSA IS Cl. I,II,III Div. 1 Gr. A-G / NI Cl. I Div. 2
	V					CSA XP Cl. I,II,III Div. 1 Gr. A-G
	N					CSA General Purpose
	K					TIIS Ex ia II C T6
	Y					Special certificate
					Process connection	
	R					G 1½" thread ISO 228
	N					NPT 1½" - 11,5 thread
	Y					Special version
					Power supply/communication	
	B					2 wire, 4...20mA-loop/HART
	H					4 wire, 10,5...32VDC / 4-20mA HART
	G					4 wire, 90...253VAC / 4-20mA HART
	D					2 wire, PROFIBUS PA
	F					2 wire, Foundation Fieldbus
	Y					Special version
					Display / on-site operation	
	1					Without LC display
	2					With LC display VU 331 incl. on-site operation
	3					Prepared for remote display FHX 40
	9					Special version
					Housing	
	A					Aluminium F12 housing coated to IP 68
	C					Aluminium T12 housing coated to IP 68; with separate terminal compartment
	D					Aluminium T12 housing coated to IP 68; with separate terminal compartment; with overvoltage protection (in preparation)
	9					Special version
					Screw union/entry	
	2					M20x1.5 screw union
	3					G 1/2" entry
	4					NPT 1/2" entry
	5					M12 PROFIBUS-PA plug-in connector
	6					7/8" FF plug
	9					Special version
FMU 40 -						Product designation

Product structure FMU 41

Certificates	
A	Variant for non-hazardous area
1	ATEX II 1/2 G or II 2 G; EEX ia IIC T6
4	ATEX II 1/2 G or II 2 G; EEX d [ia] IIC T6
S	FM IS Cl. I,II,III Div. 1 Gr. A-G / NI Cl. I Div. 2
T	FM XP Cl. I,II,III Div. 1 Gr. A-G
U	CSA IS Cl. I,II,III Div. 1 Gr. A-G / NI Cl. I Div. 2
V	CSA XP Cl. I,II,III Div. 1 Gr. A-G
N	CSA General Purpose
K	TIIS Ex ia II C T6
Y	Special certificate
Process connection	
R	G 1½" thread ISO 228
N	NPT 1½" - 11,5 thread
Y	Special version
Power supply/communication	
B	2 wire, 4...20mA-loop/HART
H	4 wire, 10,5...32VDC / 4-20mA HART
G	4 wire, 90...253VAC / 4-20mA HART
D	2 wire, PROFIBUS PA
F	2 wire, Foundation Fieldbus
Y	Special version
Display / on-site operation	
1	Without LC display
2	With LC display VU 331 incl. on-site operation
3	Prepared for remote display FHX 40
9	Special version
Housing	
A	Aluminium F12 housing coated to IP 68
C	Aluminium T12 housing coated to IP 68 with separate terminal compartment
D	Aluminium T12 housing coated to IP 68; with separate terminal compartment; with overvoltage protection (in preparation)
9	Special version
Screw union/entry	
2	M20x1.5 screw union
3	G 1/2" entry
4	NPT 1/2" entry
5	M12 PROFIBUS-PA plug-in connector
6	7/8" FF plug
9	Special version
FMU 41 -	Product designation

Product structure FMU 42

		Certificates	
	A	Variant for non-hazardous area	
	1	ATEX II 1/2 G EEX ia IIC T6 (in preparation)	
	4	ATEX II 1/2 G EEX d [ia] IIC T6 (in preparation)	
	G	ATEX II 3G EEx nA II T6 (in preparation)	
	S	FM IS Cl. I,II,III Div. 1 Gr. A-G / NI Cl. I Div. 2 (in preparation)	
	T	FM XP Cl. I,II,III Div. 1 Gr. A-G (in preparation)	
	U	CSA IS Cl. I,II,III Div. 1 Gr. A-G / NI Cl. I Div. 2 (in preparation)	
	V	CSA XP Cl. I,II,III Div. 1 Gr. A-G (in preparation)	
	N	CSA General Purpose (in preparation)	
	K	TIIS Ex ia II C T6 (in preparation)	
	Y	Special certificate	
		Process connection	
	M	mounting bracket FAU20	
	P	DN80/ANSI 3"/JIS10K80, PP, Universal flange	
	Q	DN80/ANSI 3"/JIS10K80, PVDF, Universal flange	
	S	DN80/ANSI 3"/JIS10K80, 316L, Universal flange	
	T	DN100/ANSI 4"/JIS16K100, PP, Universal flange	
	U	DN100/ANSI 4"/JIS16K100, PVDF, Universal flange	
	V	DN100/ANSI 4"/JIS16K100, 316L, Universal flange	
	Y	Special version	
		Power supply/communication	
	B	2 wire, 4...20mA-loop/HART	
	H	4 wire, 10,5...32VDC / 4-20mA HART	
	G	4 wire, 90...253VAC / 4-20mA HART	
	D	2 wire, PROFIBUS PA	
	F	2 wire, Foundation Fieldbus	
	Y	Special version	
		Display / on-site operation	
	1	Without LC display	
	2	With LC display VU 331 incl. on-site operation	
	3	Prepared for remote display FHX 40	
	9	Special version	
		Housing	
	A	Aluminium F12 housing coated to IP 68	
	C	Aluminium T12 housing coated to IP 68, with separate terminal compartment	
	D	Aluminium T 12 housing coated to IP 68, with separate terminal compartment; with overvoltage protection (in preparation)	
	Y	Special version	
		Gland/Entry	
	2	M20x1.5 gland	
	3	G 1/2" entry	
	4	NPT 1/2" entry	
	5	M12 PROFIBUS-PA plug	
	6	7/8" FF plug	
	9	Special version	
		Sealing Sensor/Flange	
	2	VITON flat sealing	
	3	EPDM flat sealing	
	9	special version	
		Additional options	
	A	Additional options not selected	
FMU 42 -			Product designation

Product structure FMU 43

Certificates	
A	Variant for non-hazardous area
2	ATEX II 1/2 D or II 2 D, Aluminium Deckel
5	ATEX II 1/3 D or II 3 D, Sichtdeckel
M	FM DIP Class II, III, Div. 1, Gr. E,F,G NI
N	CSA General Purpose
P	CSA DIP, Class II, III, Div. 1, Gr. E,F,G NI
Y	Special version
Process connection/material	
P	Flange DN 100/ANSI 4"/JIS 16K100, PP (universal slip-on flange included)
S	Flange DN 100/ANSI 4"/JIS 16K100, SS 316TI (universal slip-on flange included)
K	Without slip-on flange/without mounting bracket (customer mounting equipment)
M	With mounting bracket
Y	Special version
Power supply/communication	
H	4 wire, 10,5...32VDC / 4-20mA HART
G	4 wire, 90...253VAC / 4-20mA HART
D	2 wire, PROFIBUS PA
F	2 wire, Foundation Fieldbus
Y	Special version
Display / on-site operation	
1	Without LC display
2	With LC display VU 331 incl. on-site operation
3	Prepared for remote display FHX 40
9	Special version
Housing	
A	Aluminium F12 housing coated to IP 68
9	Special version
Screw union/entry	
2	M20x1.5 screw union
3	G 1/2" entry
4	NPT 1/2" entry
5	M12 PROFIBUS-PA plug-in connector
6	7/8" FF plug
9	Special version
FMU 43 -	Product designation

Scope of delivery

- Instrument according to the version ordered
- 2 ToF Tool CDs (1: program, 2: Device Descriptions and Documentation)
- Operating manual according to the communication version
- for certified instrument versions: Safety Instructions, Control- or Installation drawings
- for FMU 40/41 in the versions FMU 40 *R**** and FMU 41 *R****: counter nut (PA)
- for FMU 40/41: sealing ring (EPDM)

Accessories

Weather protection cover

A Weather protection cover made of stainless steel is available for outdoor mounting (order code: 543199-0001). The shipment includes the protective cover and tension clamp.

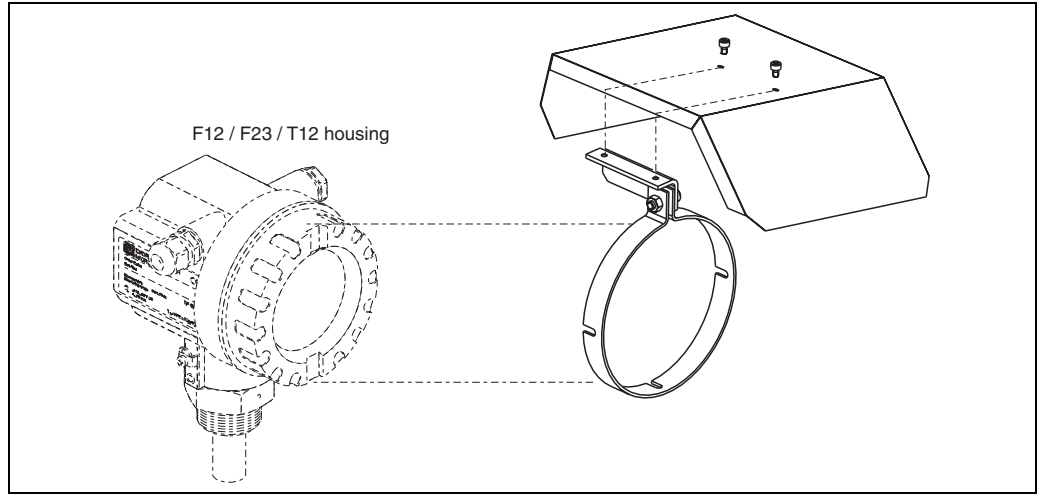

Installation bracket for FMU 40/41

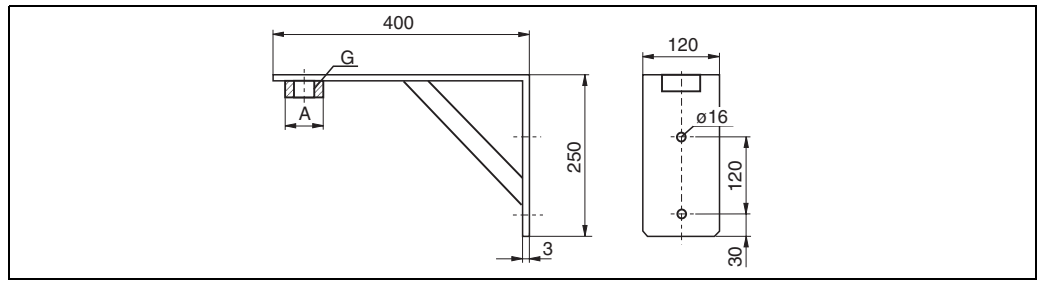

- for FMU 40, G1½: Order No. 942669-0000
 - for FMU 41, G2: Order No. 942669-0001
- suited for NPT 1½" and 2" as well

Adapter flange for FMU 40 / FMU 41

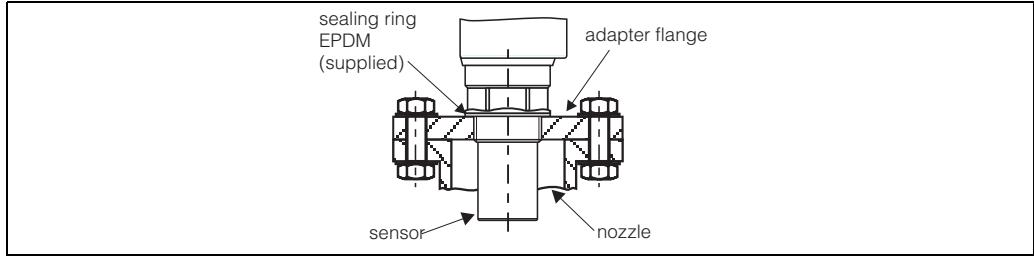

L00-FMUX3XXX-00-00-00-en-001

Version with metrical thread (FAU 70 E)

Version	
12	DN 50 PN 16
14	DN 80 PN 16
15	DN 100 PN 16
Thread	
3	G 1½, ISO 228
4	G 2, ISO 228
Material	
2	1.4435 (316L)
7	PPs (Polypropylene)
FAU 70 E	Product designation

Version with conical thread(FAU 70 A)

Version	
22	ANSI 2" 150 psi
24	ANSI 3" 150 psi
25	ANSI 4" 150 psi
Thread	
5	NPT 1½ - 11,5
6	NPT 2 - 11,5
Material	
2	1.4435 (316L)
7	PPs (Polypropylene)
FAU 70 A	Product designation

Cantilever

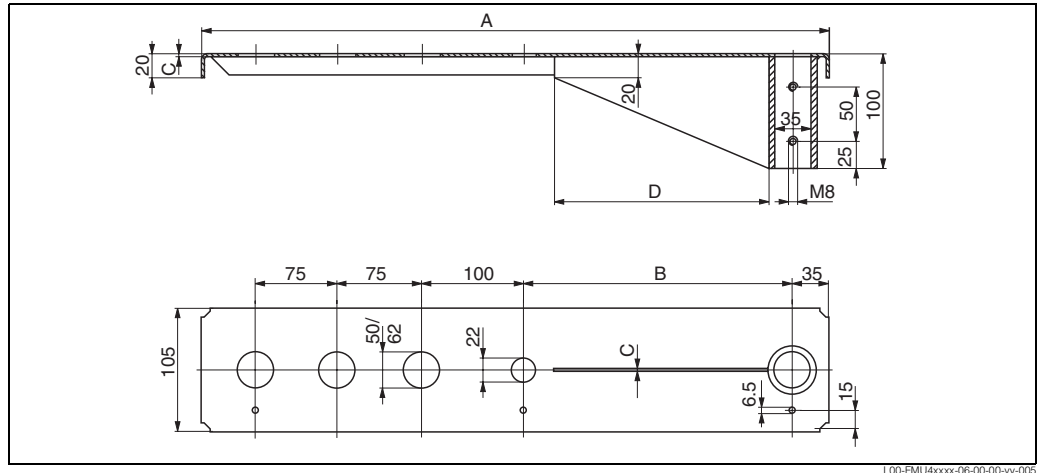

L00-FMU4xxxx-06-00-00-yy-005

A	B	C	D	for Sensor	Material	Order Code
585 mm	250 mm	2 mm	200 mm	FMU 40	1.4301 (AISI 304)	52014132
					galv. steel	52014131
				FMU 41	1.4301 (AISI 304)	52014136
					galv. steel	52014135
1085 mm	750 mm	3 mm	300 mm	FMU 40	1.4301 (AISI 304)	52014134
					galv. steel	52014133
				FMU 41	1.4301 (AISI 304)	52014138
					galv. steel	52014137

- The 50 mm or 62 mm orifices serve for the mounting of the FMU 40 or FMU 41 sensor, respectively.
- The 22 mm orifice may be used for an additional sensor.

Mounting Frame for Cantilever

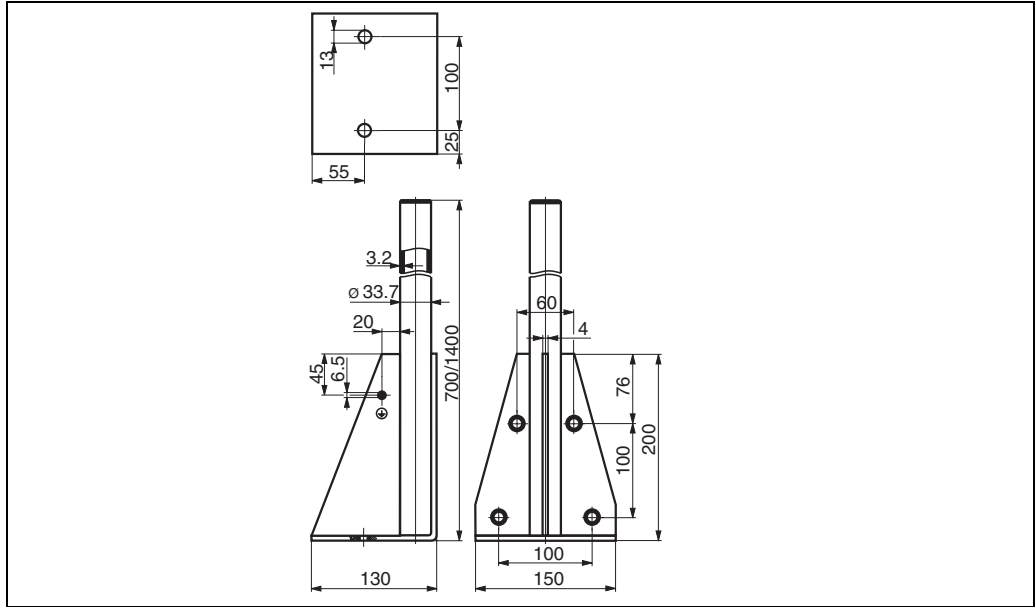

L00-FMU4x-00-00-00-yy-005

Height	Material	Order Code
700 mm	galv. steel	919791-0000
700 mm	1.4301 (AISI 304)	919791-0001
1400 mm	galv. steel	919791-0002
1400 mm	1.4301 (AISI 304)	919791-0003

Wall Bracket for Cantilever

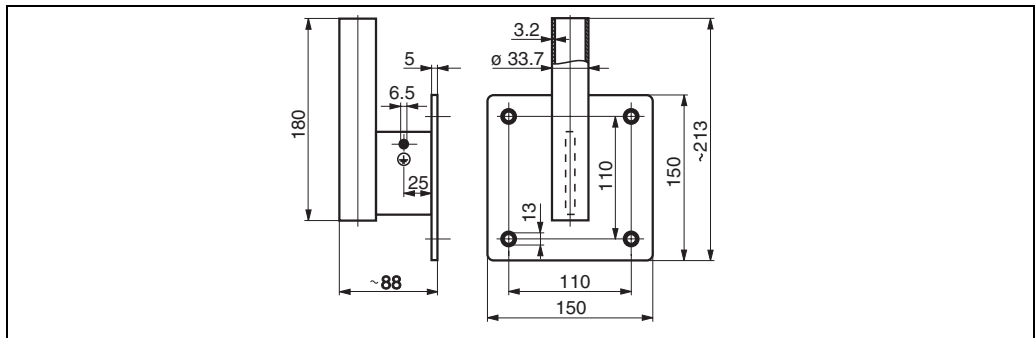

L00-FMU4x-00-00-00-yy-006

Material	Order Code
galv. steel	919792-0000
1.4301 (AISI 304)	919792-0001

Commubox FXA 191

For intrinsically safe communication between HART protocol and Personal Computer. The Prosonic can be operated either with the ToF Tool program or with the Commuwin II program. You can find additional information in Technical Information TI 237F/00/en.

Service Interface FXA 193 For communication with ToF Tool via the display connector.

Ordering structure:

- FXA 193-A: for use in non-hazrdous area
- FXA 193-B: for use in hazardous area (ATEX, CSA, FM)

The connection to a ToF device needs an additional FXA connection cable (order code.: 50101787).

Remote display FHX 40 Dimensions

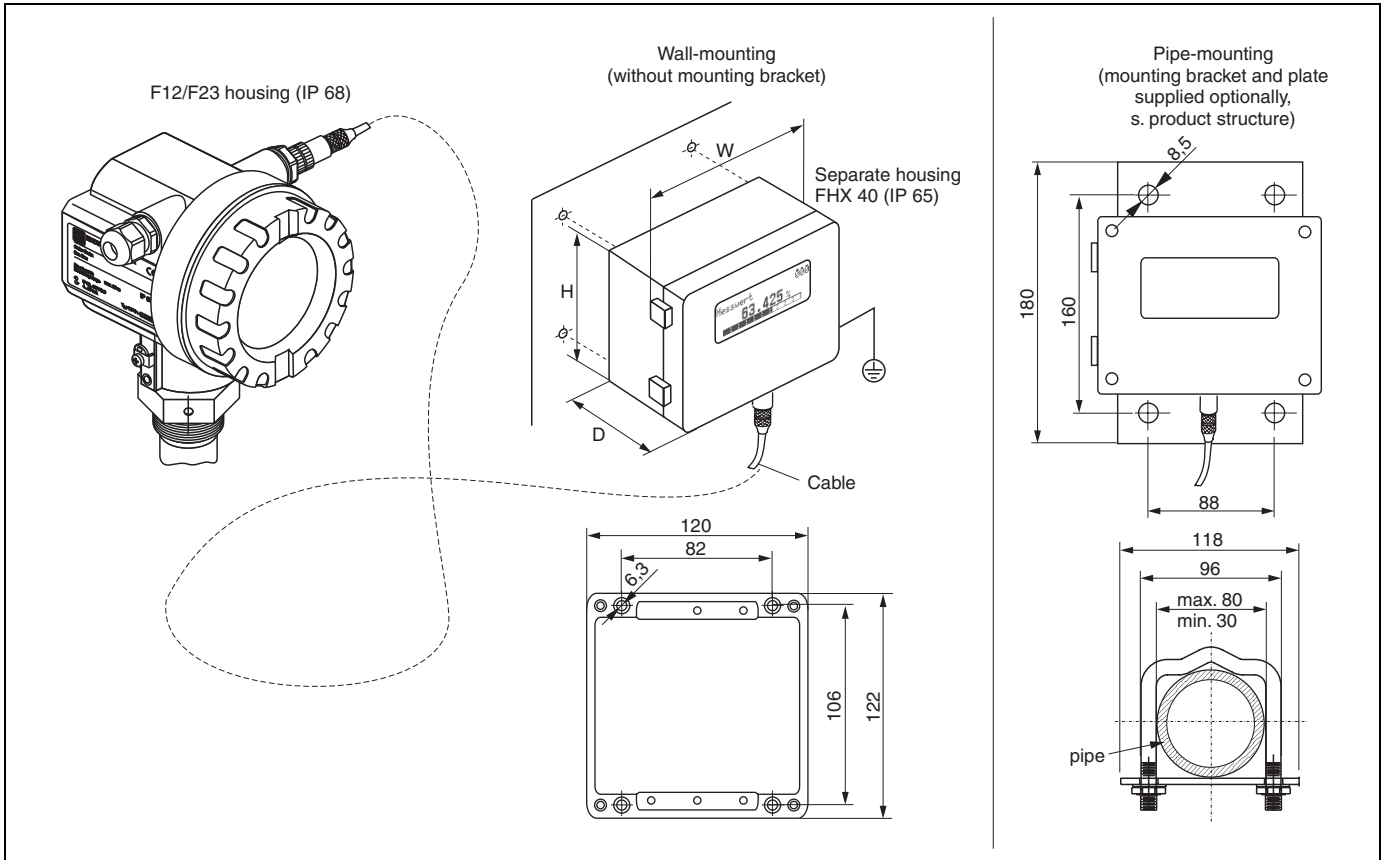

L00-FMxxxxx-00-00-06-en-003

Technical data:

Max. cable length	20 m (65 ft)
Temperature range	-30 °C...+70 °C (-22 °F...158 °F)
Degree of protection	IP65 acc. to EN 60529 (NEMA 4)
Material for housing	Alloy of Aluminium AL Si 12
Dimensions [mm] / [inch]	122x150x80 (HxBxT) / 4.8x5.9x3.2

Ordering structure

Certificates	
A	For non-hazardous area
1	ATEX II 2 G EEx ia IIC T6, ATEX II 3D
S	FM IS Class I Div. 1, Groups A,B,C,D
U	CSA IS Class I, Div. 1, Groups A,B,C,D
N	CSA General Purpose (in preparation)
Cable length	
1	20 m cable
Additional option	
A	Additional option not selected
B	Mounting bracket 1" or 2" pipe
FHX 40 -	Complete product designation

Supplementary documentation

System Information

SI 005F/00/en

Ultrasonic level measurement

Operating manual

Depending on the communication variant ordered, the following operating manuals are supplied with the device:

Communication	Operating manual
4 ... 20mA, HART	BA 237F
Profibus PA	BA 238F
Foundation Fieldbus	BA 239F

These instructions describe the installation and first commissioning of the Prosonic M. From the operating menu, all functions are included, which are required for standard measurement tasks. Additional functions are **not** contained in the manual.

Description of device functions

BA 240F

This contains a detailed description of **all** the functions of the Prosonic M and is valid for all communication variants. This document is located on the supplied documentation CD-ROM in the form of a pdf file. It is also available on the Internet at www.endress.com.

Short instructions

KA 183F

can be found under the device housing cover.

The most important menu functions are summarised on this sheet. It is intended primarily as a memory jogger for users who are familiar with the operating concept of Endress+Hauser time-of-flight instruments.

Safety Instructions

The following safety instructions are supplied with ATEX-certified device versions:

Version	Certificate	Communication	Safety Instructions
<ul style="list-style-type: none"> ● FMU 40 - 1*B*** ● FMU 41 - 1*B*** 	ATEX II 1/2 G bzw. II 2 G EEx ia II C T6	HART	XA 174F
<ul style="list-style-type: none"> ● FMU 40 - 1*D*** ● FMU 40 - 1*F*** ● FMU 41 - 1*D*** ● FMU 41 - 1*F*** 	ATEX II 1/2 G bzw. II 2 G EEx ia II C T6	<ul style="list-style-type: none"> ● Profibus-PA ● Foundation Fieldbus 	XA 175F
<ul style="list-style-type: none"> ● FMU 40 - 4**** ● FMU 41 - 4**** 	ATEX II 1/2 G bzw. II 2 G EEx d [ia] II C T6	<ul style="list-style-type: none"> ● HART ● Profibus-PA ● Foundation Fieldbus 	XA 176F
<ul style="list-style-type: none"> ● FMU 43 - 2*G*** ● FMU 43 - 2*H*** ● FMU 43 - 5*G*** ● FMU 43 - 5*H*** 	<ul style="list-style-type: none"> ● ATEX II 1/2 D bzw. II 2 D ● ATEX II 1/3 D bzw. II 3 D 	HART	XA 177F
<ul style="list-style-type: none"> ● FMU 43 - 2*D*** ● FMU 43 - 2*F*** ● FMU 43 - 5*D*** ● FMU 43 - 5*F*** 	<ul style="list-style-type: none"> ● ATEX II 1/2 D bzw. II 2 D ● ATEX II 1/3 D bzw. II 3 D 	<ul style="list-style-type: none"> ● Profibus-PA ● Foundation Fieldbus 	XA 178F

If the devices are used in explosive areas, comply with all the specifications in these safety instructions.

Control drawings
Installation drawings

The following control or installation drawings are supplied with the FM, CSA and TIIS-certified device versions:

Version	Certificate	Communication	Housing	Control- or Installation Drawing
<ul style="list-style-type: none"> ● FMU 40 - S*B*A* ● FMU 41 - S*B*A* 	FM IS	HART	F12	ZD 096F
<ul style="list-style-type: none"> ● FMU 40 - S*D*A* ● FMU 40 - S*F*A* ● FMU 41 - S*D*A* ● FMU 41 - S*F*A* 	FM IS	<ul style="list-style-type: none"> ● Profibus-PA ● Foundation Fieldbus 	F12	ZD 097F
<ul style="list-style-type: none"> ● FMU 40 - T***C* ● FMU 41 - T***C* 	FM XP	<ul style="list-style-type: none"> ● HART ● Profibus-PA ● Foundation Fieldbus 	T12	ZD 098F
<ul style="list-style-type: none"> ● FMU 40 - U*B*A* ● FMU 41 - U*B*A* 	CSA IS	HART	F12	ZD 088F
<ul style="list-style-type: none"> ● FMU 40 - U*D*A* ● FMU 40 - U*F*A* ● FMU 41 - U*D*A* ● FMU 41 - U*F*A* 	CSA IS	<ul style="list-style-type: none"> ● Profibus-PA ● Foundation Fieldbus 	F12	ZD 099F
<ul style="list-style-type: none"> ● FMU 40 - V***C* ● FMU 41 - V***C* 	CSA XP	<ul style="list-style-type: none"> ● HART ● Profibus-PA ● Foundation Fieldbus 	T12	ZD 100F
<ul style="list-style-type: none"> ● FMU 40 - K***** ● FMU 41 - K***** 	TIIS Ex ia IIC T6	HART	F12	ZD 138F
FMU 43 - M*****	FM DIP	<ul style="list-style-type: none"> ● HART ● Profibus-PA ● Foundation Fieldbus 		no Control- or Installation Drawing
FMU 43 - P*****	CSA DIP	<ul style="list-style-type: none"> ● HART ● Profibus-PA ● Foundation Fieldbus 		no Control- or Installation Drawing

Endress+Hauser GmbH+Co.

Instruments International
P.O. Box 2222
D-79574 Weil am Rhein
Germany

Tel. (07621) 975-02
Tx 773926
Fax (07621) 975 345
e-mail: info@ii.endress.com

Internet:

<http://www.endress.com>

Endress + Hauser

The Power of Know How

