

Sample Valves & Equipment

SANITARY SAMPLING VALVES

Operation & Maintenance Manual

May 2014
Sample Valves & Equipment
3725 Interpark Drive
Colorado Springs, CO 80907
Tel: 719-260-5694 • Fax: 719-260-5944

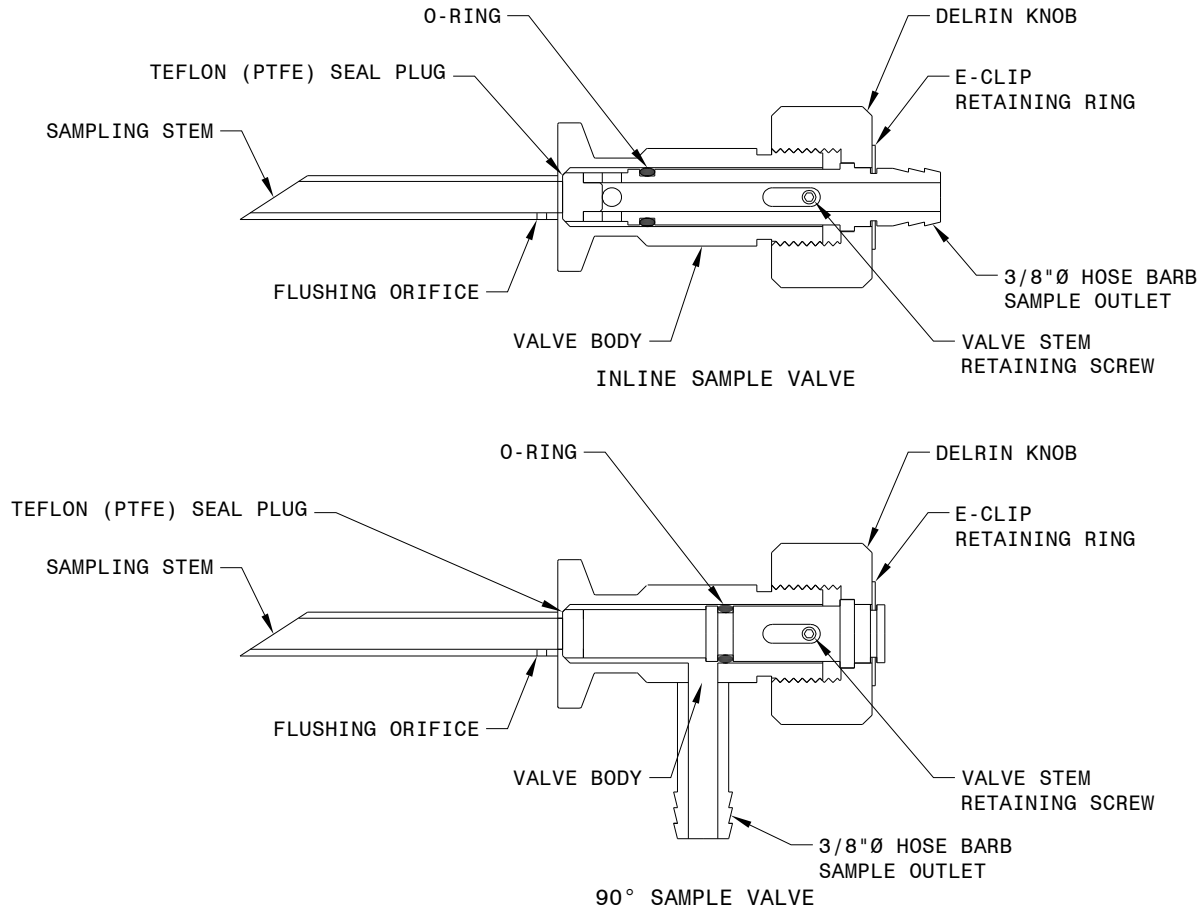

Figure 1: Sanitary Sampling Valve Components

INTRODUCTION

The SV&E Sanitary Sampling Valve is ideal for the sterile sampling of high purity water and other liquids in distribution lines, filter housings or storage tanks. The port can be sanitized effectively and easily in place to eliminate residual viable contaminants and prevent additional contaminant growth.

The unique construction of the Sanitary Sampling Valve allows the use to sample mid-stream and works to prevent accumulation of bacteria or particles inside the sampling probe. The 1/4" hose barb sample outlet may be diverted to a bacteriological monitor or for directing liquid flow into any type of sterile receiver (graduated cylinder or Whirl-Pak™ bag).

Note: The following is only a suggested technique for sanitization. There are many options for cleaning including an Autoclave. It is up to the customer and situation to determine the proper sanitizing method.

SANITIZATION

Sanitize the Sanitary Sampling Valve immediately after installation and after each sampling operation:

1. Flush the port by opening the valve and allowing a full flow of liquid to pass out of the sample outlet for 1-2 minutes. Then close the valve.
2. Fill a 20 mL plastic polypropylene syringe with at least 10 mL of 70% ethanol, 90% isopropyl alcohol, or 3% hydrogen peroxide solution.
3. Attach a 2" long blunt-end needle to the syringe.
4. Insert the needle into the valve as far as possible through the sample outlet, and express the sanitant into the port. Allow a few milliliters to flow out of the sample outlet.
5. As the needle is removed from the opening, squirt a few milliliters of the sanitant over the outer surface of the sample outlet.
6. Cap the sample outlet. This will keep the valve sanitized between sampling operations.

OPERATION

You can collect liquid samples from the Sanitary Sampling Valve by following one of the procedures below:

Whirl-Pak™ Bag Collection:

1. Lay out an unopened bag on a clean, flat surface.
2. Mark a straight line onto the outside of the bag with a permanent felt-tip marker 3 ½ inches from the bottom of the bag. This mark represents a volume size of 100 mL when the bag is full. (If a smaller sample is required, mark the bag fill-position accordingly.)
3. Taking care not to touch the mouth of the bag (at perforation line) with your fingers, hold one of the yellow tabs and tear off the perforated portion. Hold the white tabs between thumb and forefinger of each hand, then pull the bag open.
4. If used, remove the plastic cap from the sample outlet, then open the valve.
5. Allow 100 mL to 200 mL of sample to flush the port to remove all residual sanitant.
6. Place the Whirl-Pak™ bag beneath the port outlet and allow the bag to fill up to the calibration mark. Close the valve.
7. Holding the bag by the yellow tabs, pull them to close the mouth of the bag. While holding firmly, swing the bag over on itself 2 or 3 times in a whirling motion to close the bag. Fold over the tabs.
8. Place the bag in a rack or suitable container and refrigerate until ready for analysis. The analysis should be performed within 2 hours of taking the sample.
9. Sanitize the valve.

Graduated Cylinder Collection:

1. Choose a sterilized graduated cylinder or other type of container marked at the appropriate volume required.
2. If used, remove the plastic cap from the sample outlet. Open the valve. Before collecting a sample in the container, flush the valve with 100 mL to 200 mL of sample.
3. Place the container beneath the sample outlet and fill to the level required. Close the valve.
4. Cover the sample container with sterile (flamed) aluminum foil until ready for analysis. The analysis should be performed within 2 hours.
5. Sanitize the valve.

MAINTENANCE

Minor maintenance is required for the Sanitary Sampling Valve. The valve should be periodically removed, disassembled, cleaned and the O-ring and plug seal condition examined. Replace these parts if needed. To disassemble the valve, gently pry off the E-clip retaining ring. Unscrew the Delrin® knob and remove it from the valve. Remove the valve shaft retaining set-screw and slide the valve shaft out of the valve body. Clean the parts individually, then re-assemble the valve.

CAUTION: Do not use chlorine or other halogen agents as either a sanitant or cleaning compound. Halogens will attack stainless steel. Use only detergents and short bristle brushes to clean. A mild abrasive may be used if deposits are stubborn. Use a pipe cleaner, moistened with cleanser, to clean the inside of the valve body, sampling stem, and valve shaft (inline models only).

SPECIFICATIONS

Materials: 316 stainless steel; Teflon (PTFE) seal plug and Delrin® knob; Silicone O-ring standard.

Connections: Tri-Clamp®, NPT & weld style process connection; 3/8" Hose Barb sample outlet.

Pressure (maximum): Up to 300 psi at 200° F or 400 psi at 100° F

Notice: SV&E is constantly striving to improve its products and services. Consequently, the information in this document is subject to change without notice and should not be construed as a commitment by SV&E. Also, SV&E assumes no responsibility for any errors that may appear in this document. This manual is believed to be complete and accurate at the time of publication. In no event shall Optimum filter be liable for incidental or consequential damages in connection with or arising from the use of this manual.

Delrin is a trademark of Dupont. Tri-Clamp is a trademark of Tri-Clover, Inc.

Minncare is a trademark of Minntech Corporation. © 2011 SV&E LLC.

Printed in the United States of America. All rights reserved.