

HP-Series

The Hand Lever Pumps from 1000 – 4000 bar
Rugged – Efficient – Safe

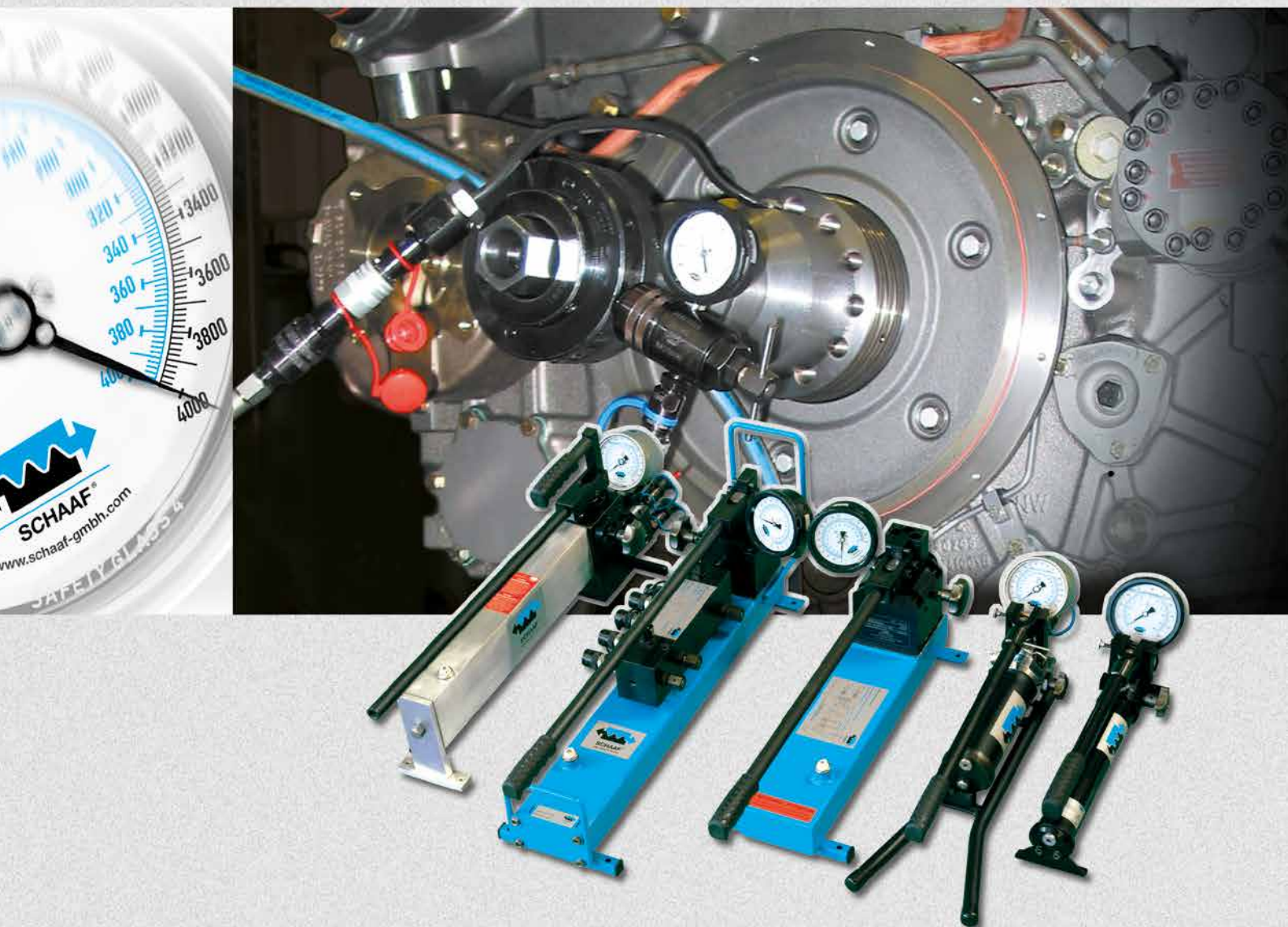

HP-Series – low maintenance
and ready for immediate use.



HP-Series

Hand Lever Pump overview

	HP 1000 / 1600-LT		HP 1600-1S		HP 1600-2S		HP 3000-HT		HP 4000-LT	
Pump type:	Hand Lever Pump		Hand Lever Pump		Hand Lever Pump		Hand Lever Pump		Hand Lever Pump Short Long	
Geometric volume / Conveying performance:	1.1 cm ³ / Hub		1.8 cm ³ / Hub		Step 1: 2.8 cm ³ / stroke up to ca. 600 bar Step 2: 1.3 cm ³ / stroke up to ca. 1600 bar		Step 1: 32 cm ³ / stroke up to ca. 30 bar Step 2: 0.9 cm ³ / stroke up to 3000 bar Step 2: 0.6 cm ³ / stroke up to 4000 bar		0.39 cm ³ / stroke	
Max. hydraulic pressure:	1000 bar	1600 bar	1600 bar		1600 bar		3000 bar	4000 bar	4000 bar	
Safety valve:	Positioned outside, pre-set to max. pump pressure		Positioned inside, pre-set to max. pump pressure		Positioned inside, pre-set to max. pump pressure					
Pressure connection:	According to type code Broadest range of variations		According to type code Broadest range of variations		According to type code Broadest range of variations		According to type key Broadest range of variations		According to type key Broadest range of variations	
Tank content:	0.6 litre	0.9 litre	3.3 litre		3.7 litre		1.9 litre		0.73 litre	1.5 litre
Useable volume:	0.5 litre	0.8 litre	3.1 litre		3.4 litre		1.7 litre		0.63 litre	1.3 litre
Hydraulic oil:	HLP ISO VG 15		HLP ISO VG 15		HLP ISO VG 15		HLP ISO VG 15		HLP ISO VG 15	
Tank:	Steel tank coated		Steel tank coated		Steel tank coated		Aluminium		Steel tube tank	
Weight (filled with oil, without dis- tributor, without pressure gauge)	6,1 kg.	6,9 kg	19 kg		24 kg		17 kg		11 kg	10 kg
Length:	497 mm	640 mm	750 mm		870 mm		830 mm		651 mm	660 mm
Width:	115 mm		270 mm		270 mm		200 mm		199 mm	130 mm
Height with pressure gauge:	196 mm		285 mm		280 mm		292 mm (Ø 100) / 300 mm (Ø 160)		218 mm	215 mm
Pressure gauge Standard: (Class 1.0, filled with glycerine):	Ø 100, 1000 bar	Ø 100, 1600 bar	Ø 100, 1600 bar		Ø 100, 1600 bar		Ø 100, 3000 bar	Ø 100, 4.000 bar	Ø 100, 4000 bar	
Tested load alternations up to max. pressure	20,000		150,000		150,000		150,000		50,000	
Areas of Application:	small	big	small	big	small	big	small	big	small	big
SSV single / HM single	++	+	++	+	++	+	++	+	O	+
SSV multiple / HM multiple	+	-	+	-	++	+	+	O	O	+
Oil press-fit radial	O	-	O	-	O	-	++	+	++	++
ExpaTen	O	-	O	-	O	-	+	O	-	-
GripLoc	O	-	O	-	O	-	O	-	-	-

Labelling:

++ Highly recommended O Limited recommendation
+ Recommended - Not recommended



All pumps are of an extremely rugged design. All high-pressure valves are manufactured with hardened valve seats. This ensures exceptionally long service life and ruggedness with regard to contaminants in the hydraulic circuit. All pumps are therefore perfectly suited for rough conditions at construction sites. All pumps are CE classified, undergo extensive quality assurance checks during production and are supplied with extensive documentation.

Advantages

The SCHAAF **Hand Lever Pumps** are specially designed for industrial use. Consequently, it is a reliable high-pressure generator:

- Rugged, durable design
- Immediately ready for use, fully assembled and oil filled
- All components sealed leakproof
- Pump body of high-strength quenched and tempered steel
- Hardened, replaceable valve seats
- All steel components burnished
- Low maintenance level during operation

Special designs

All special versions are possible.

Please let us know your requirements.

Quality Assurance

All Hand Lever Pumps are checked for material quality, dimensional accuracy, correct functioning and load-resistance. During order execution, they are subject to continuous quality assurance measures and are supplied together with detailed technical documentation.

Services

Hand Lever Pumps are, of course, oil filled and ready for immediate use. SCHAAF Hand Lever Pumps are user-friendly, reliable, and manufactured in accordance with the highest level of technical know-how. Our highly-motivated staff would be pleased to train your personnel, in situ or at our works, in the general handling and operation of high-pressure equipment.

Complete solution from SCHAAF

The accessories for the HP Series such as hydraulic hoses and connection couplings, are aligned to the functions = 100 % system solution.



Type code of all pumps and additional information under www.schaaf-gmbh.com



SCHAAF Accessories and additional product groups

- High-pressure hydraulic hoses
- Couplings, nipples, adapters and distributor blocks for pressures up to 4,000 bar
- Bolt Tensioners (SSV)
- TTG Nuts and Bolts
- ShrinkNut
- Hydraulic Nuts (HM)
- GripLoc, GripLoc - MSN
- ExpaTen Bolts, ExpaHub, ExpaTen QL

Certificates and Acceptance Tests

- Specific test reports
- Certificates as per special customer requirements

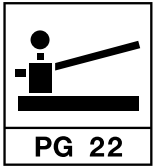

HP 1000/1600-LT

One-stage hand lever pump for hydraulic pressures up to 1600 bar, completely assembled and ready for immediate use

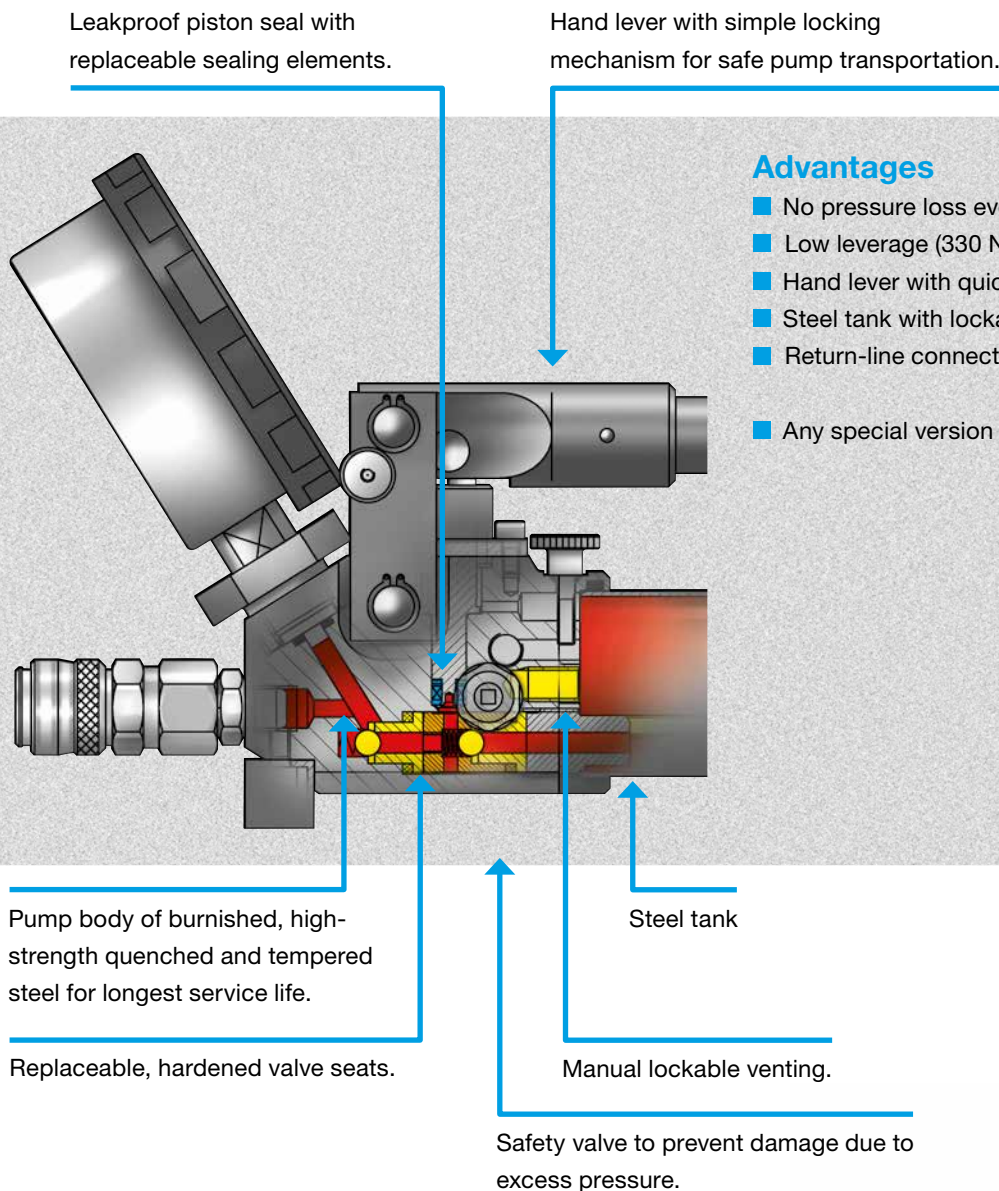

Advantages

- No pressure loss even at 1600 bar
- Low leverage (330 N/400 N at 1000/1600 bar)
- Hand lever with quick lock
- Steel tank with lockable venting
- Return-line connection G $\frac{1}{4}$ "
- Any special version possible

Areas of Application

SCHAAF HP 1000/1600-LT are ideally suited for:

- The use of bolt tensioners and hydraulic nuts
- Tightening and loosening of oil press fits (e.g., gearwheels, flywheels, coupling hubs, roller bearings, hydraulic couplings and overload protection devices)



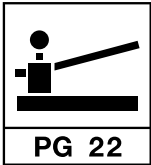

HP 1600-1S / -2S

One or two-stage hand lever pump for hydraulic pressures up to 1600 bar, completely assembled and ready for immediate use

Leakproof piston seal with replaceable sealing elements.

Individual distributor blocks for one to six connections. The HP 1600-2S connections may also be individually sealed as required.

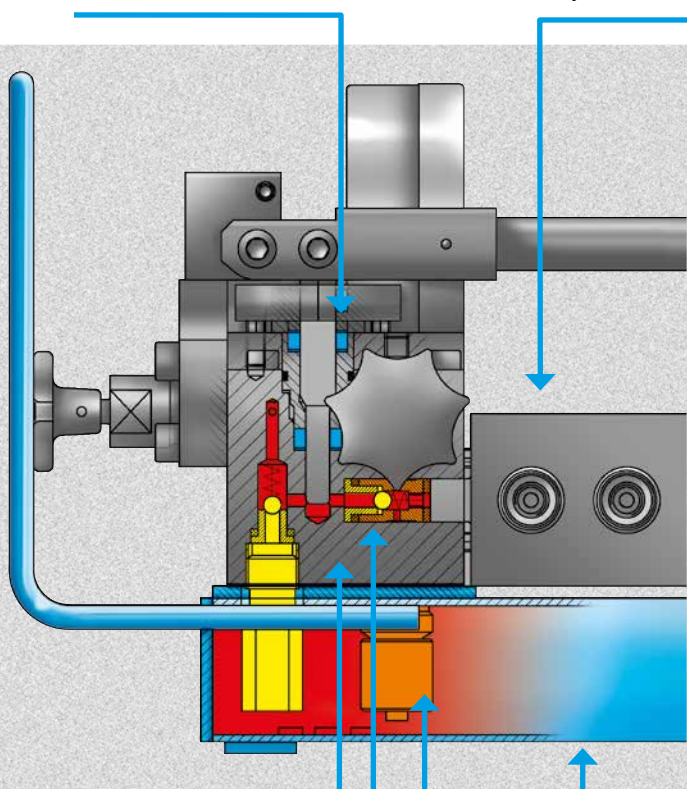

Pump body of burnished, high-strength quenched and tempered steel for longest service life.

Steel tank

Safety valve to prevent damage and excess pressure.

Replaceable, hardened valve seats.

Advantages

- Integrated, adjustable pressure limitation valve
- Perm. installed hand lever (Low leverage)
- Integrated swarf separator and intake strainer for clean oil
- Venting and return-line connection
- Pressure relief valve with internal tank return line
- Even at 1600 bar no pressure loss

SCHAAF HP 1600-2S are especially suited for:

- simultaneous pressurisation while using multiple bolt tensioners
- bolt tensioning passes for large dimension bolts (> M56)

Thanks to its two-stage pressurisation (manual switching), hand lever action is reduced because at up to 600 bar by 2.2 times the amount of oil is pumped.

Areas of Application

SCHAAF HP 1600 are ideally suited for:

- The use of bolt tensioners and hydraulic nuts
- Tightening and loosening of oil press fits (e.g., gearwheels, flywheels, coupling hubs, roller bearings, hydraulic couplings and overload protection devices)

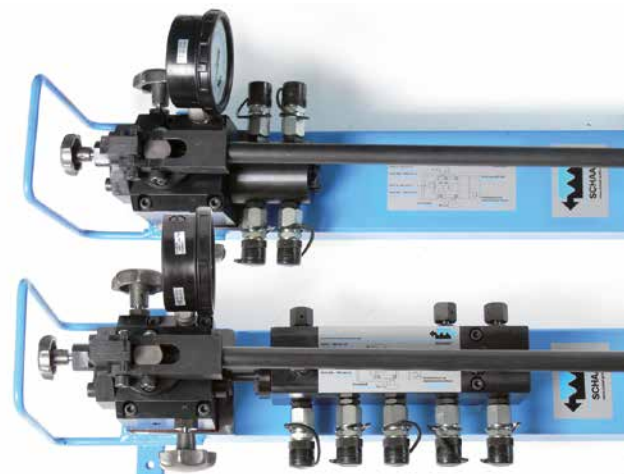

Example (top): HP 1600-2S with 4 outlets
 Example (bottom): HP 1600-2S with 5 outlets, 3 of these with separately shutoff valve

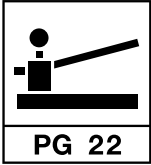

HP 3000-HT

Two-stage hand lever pump for pressures up to 3000 bar, completely assembled and ready for immediate use

Leakproof piston seal with replaceable sealing elements.

Pump handle as hand lever extension and for safe pump transportation.

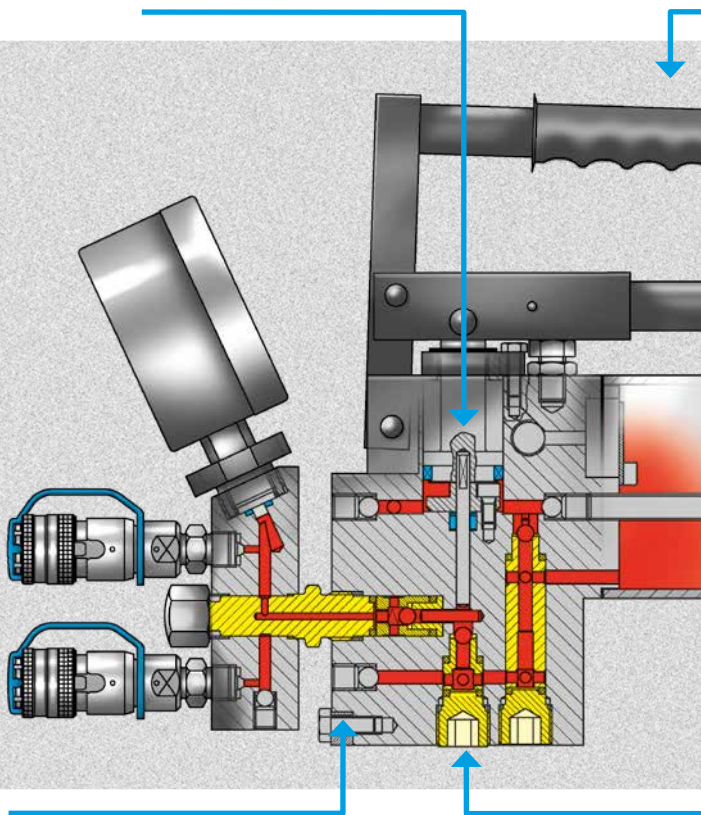

Advantages

- Two-stage, automatic-switchover, hand lever pump
- No pressure loss even at 3000 bar
- Low leverage (400 N at 3000 bar)
- Pressure relief valve with internal tank return line
- Pressure tested: 150,000 load alternations (0 bar-max. pressure)
- Any special version possible

➔ HP 3000/4000-HT with alle advantages and up to 4000 bar hydraulic high-pressure.

Pump body of high-strength quenched and tempered steel for longest endurance.

Replaceable, hardened valve seats.

Areas of Application

The SCHAAF HP 3000-HT is ideally suited for:

- The use of Bolt Tensioners, Hydraulic Nuts, ExpaTen, GripLoc and ExpaHub
- Tightening and loosening of oil press fits (e.g., gearwheels, flywheels, coupling hubs, roller bearings, hydraulic couplings and overload protection devices)



HP 3000-HT mining version

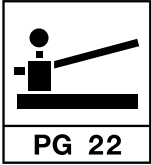

HP 4000-LT

Completely assembled and ready for immediate use
hand lever pump for hydraulic pressures up to 4000 bar

Leakproof piston seal with replaceable sealing elements.

Hand lever with simple locking mechanism for safe pump transportation.

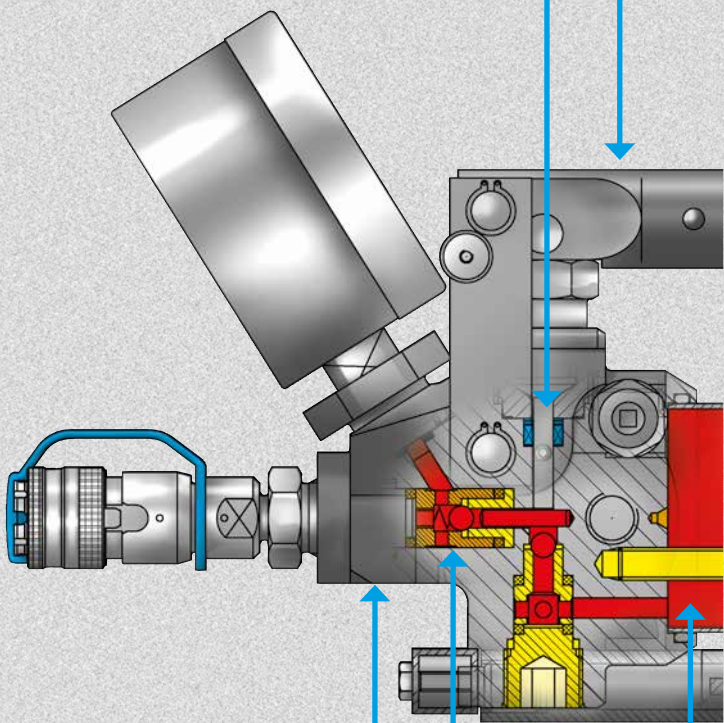

Advantages

- Quickly dismantlable for transport
- No pressure loss even at 4000 bar
- Low leverage (400 N at 4000 bar)
- Hardened, replaceable valve seats
- Fixed steel pipe tank with pedestals
- Venting and return-line connection G1/4"
- Perm. installed hand lever with quick-acting locking mech.
- Pressure tested: 50,000 load alternations (0 bar - max. pressure)
- Stable ground contact for workshop and construction site

- Any special version possible

Pump body of high-strength quenched and tempered steel for longest endurance.

Steel tank

Replaceable, hardened valve seats.

Areas of Application

The SCHAAF HP 4000-LT is ideally suited for:

- Tightening and loosening of oil press fits (e.g., gearwheels, flywheels, coupling hubs, roller bearings, hydraulic couplings and overload protection devices)
- The use of bolt tensioners, hydraulic nuts and ExpaTen Bolts



Complete portable pump assembly for oil press fits

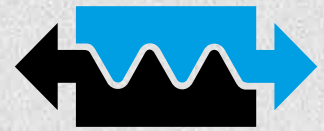

SCHAAF GmbH & Co. KG

Bruesseler Allee 22
41812 Erkelenz - Germany

Telephone: +49 - 24 31-9 77 70-0
Fax: +49 - 24 31-9 77 70-77

E-Mail: info@schaaf-gmbh.com
Internet: www.schaaf-gmbh.com

