

---

**User's  
Manual**

**51001  
Digital  
Illuminance Meter**

---

# CONTENTS

Overview .....	2
Prior to Use .....	3
Operation .....	5
Illuminance Measurement .....	11
Data Hold .....	12
Timer Hold .....	13
Range Hold .....	13
Deviation Display .....	14
Data Output .....	16
Recorder Output (Analog Output) .....	19
Separation of Light Detector .....	20
After-sales Servicing .....	21
Specifications .....	22
Characteristics of Relative Visible-spectrum Response .....	23
Characteristic of Oblique Incident Light .....	25
Illuminance Measurements for Lighting Installations (Extract from JIS C 7612 standards) .....	26

Copyright Nov. 1994 (YG). 5th Edition: Apr. 2007 (KP)

## Overview

Thank you very much for purchasing our Digital Illuminance Meter. Prior to its use, thoroughly read this instruction manual to observe the correct way of use.

Our digital illuminance meter is a small, lightweight meter and enables illuminance measurements with the meter separated from the light detector. The display adopts a large liquid crystal display (LCD) for ease in reading, and attention is also paid to operation key arrangement. The photoelectric element adopts a silicon photodiode for correcting the spectral luminous efficiency by combining with an optical filter in order to measure the illuminance of natural light. There is a microcomputer incorporated in this meter to realize an illuminance meter having excellent functions. There are also various functions incorporated in this meter, not found in conventional meters: a data-hold function; a timer-hold function; deviation display; an automatic power-off function; a response selection function; and others. Refer to the text for details on these respective functions. Moreover, this illuminance meter provides recorder output and digital data output, further extending its usefulness. Thus, the range of applications of this meter is much more extensive than that of existing luxmeters (illuminance meters).

This digital illuminance meter has been designed, manufactured, and delivered under strict quality control criteria by a factory certified in the ISO 9001 Quality Standards. We hope you will be able to make sufficient use of the performance of this product, in addition to our traditional photocell luxmeters.

Please retain this instruction manual for future use in operating this product.

## Prior to Use

### Checking accessories

After unpacking the meter, check it for appearance and its accessories.

Accessories: Instruction manual: 1

Recorder output plug (JC017A): 1

Soft-sided case (RB038A): 1

One dry cell battery (9 V) in the meter.

### Precautions on Handling

- Exercise care not to drop the meter or hit it with a hard object.
- Avoid placing the meter in a room at a temperature above 60°C or below -20°C. Also, avoid placing it in an area subject to direct sunlight or at a high humidity.
- Using the meter at low temperatures (between -10 and 0°C) causes the display response to be delayed.
- Avoid using the meter in a dirty, dusty, or salt-air area or where there are corrosive gases.
- Dirt or dust adhering to the light-detecting surface decreases measurement accuracy. Wipe the surface clean with a soft, dry cloth.
- Do not use solvent (trichloroethylene, paint thinner, benzene, alcohol, etc.), which may deform the case material or cause the print to peel off. To remove stains from the case, gently wipe them off with a soft cloth. If the instrument is badly stained, use a soft cloth moistened with a neutral detergent, then wipe off the moisture using a dry cloth.
- Do not disassemble the meter.
- Do not separate mainunit from light-detector with the power on.

## Safety Summary

The CAUTION Which appear on the following page must be followed to ensure operator safety and to retain the operating condition of the Illuminance Meter,

## Safety Symbol



Indicates the operator must refer to an explanation in this manual.

## Calibration

Calibrate the meter once every two years in order to maintain accurate measurements. Calibration is done by Yokogawa. To have the meter calibrated, consult the Yokogawa sales representative from whom you purchased the instrument or the Yokogawa sales division listed on the back of this manual.

## Optional Accessories

Product	Specification	Model
Light-detector extension cable	3m	910 01
	30m	910 02
Data output cable	3m	910 03
AC adaptor	120 V (DC 9V)	940 01
	220 V (DC 9V)	940 02

### Note

Accessories of non-standard

Safety standard: EN 61010-1

- AC adaptor      Model: 94001(Input of 120 V $\pm$  10% AC)  
                         Model: 94002(Input of 220 V $\pm$  10% AC)

EMC standard:

- Light-detector extension cable  
                         Model: 91002(Cable length: Approx. 30 m)



## CAUTION

Danger of electrical shock!

- When you use the AC adaptor, never use a power supply that is not suited to the adaptor.
- Handle the AC adaptor with care so that the adaptor is not damaged. If the adaptor is damaged, do not use it.

# Operation

## Components

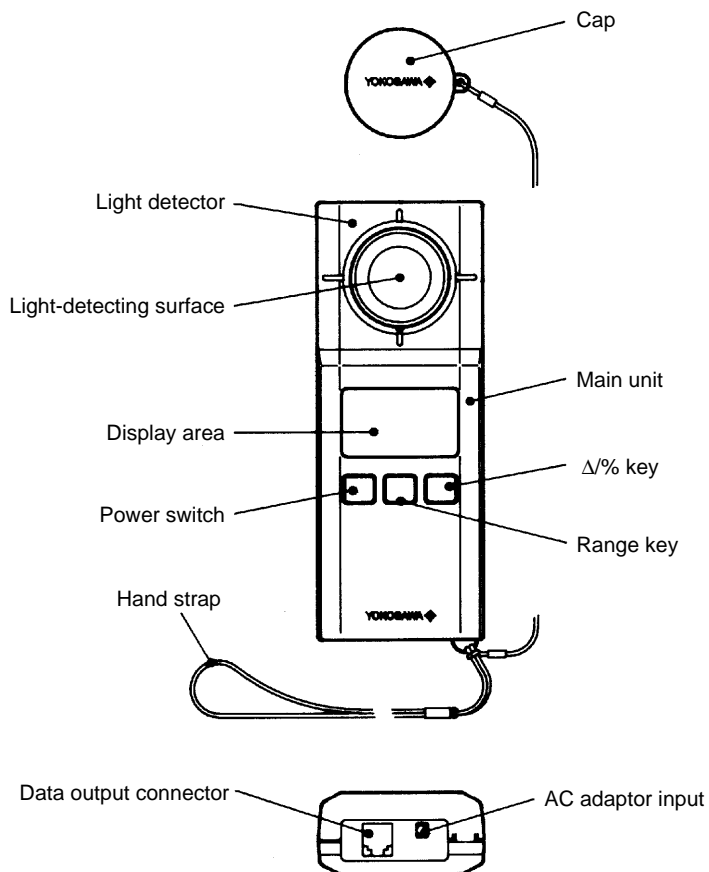
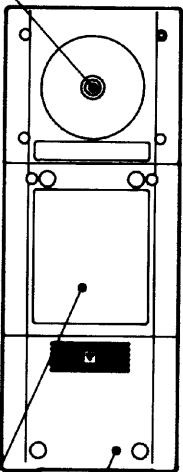

Figure 1. Components

Measuring reference plane indication



Tripod-mounting screw



Hold switch



Recorder output connector

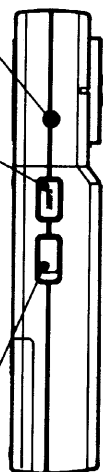

Eject button

Battery cover

Rating nameplate

Response selector switch

## Display Area

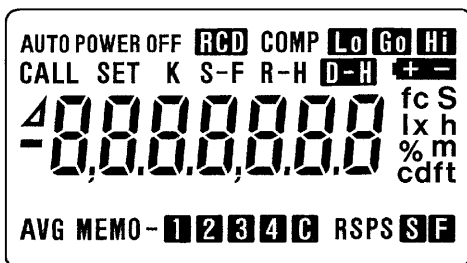

Figure 2. All Display Elements (some are unused)

## Description of Elements in Display Area

Element	Display condition/indication
8,8.8.8,8.8.8	Digital display of measured value, calculated value, and set value
AUTO POWER OFF	Indicates meter in automatic power-off mode
$\Delta$	Deviation
<b>REC</b>	Indicates when a plug is inserted into the recorder output connector
R-H	Indicates range hold
<b>D-H</b>	Indicates data hold and timer hold
<b>Lo</b>	Indicates low battery voltage
RSPS	Response setup display
lx	Unit of illuminance
fc	Unit of illuminance
%	Deviation display (%)



## Prior to Operation

### 1. Response Time Setup

The response speed of the light detector can be selected using the response selector switch. The response speed is set as described below. Set the switch to FAST or SLOW according to its application. When FAST is set, [RSPS **F**] appears; when SLOW is set, [RSPS **S**] appears in the display area.

Switch position	Response speed	Application
FAST	Approx. 10 mS	Measurement of continuous light Daylight, interior lighting (fluorescent lamps, incandescent lamps), etc.
SLOW	Approx. 500 mS	Measurement of average illuminance such as flickering lights or variations from measuring beams such as TV screens

Note: If the recorder output is used for waveform observation, set the switch to FAST

### 2. Replacement of Battery

If the battery voltage drops during operation, a [**⎓**] sign appears in the display area. In this case, replace the battery with a new one immediately. Check the polarity markings in the battery compartment and battery's polarity in order to avoid putting in the battery incorrectly. Use either a 6F22 9-V dry cell battery (S-006P, manganese, with approximately a 25-hour service life) or a 6LR61 9-V dry cell battery (alkaline dry cell battery with approximately a 40-hour service life).

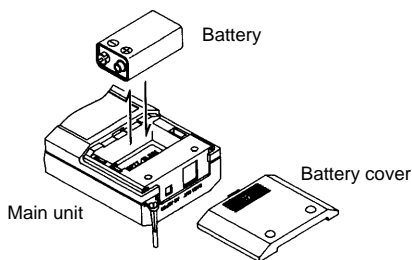

**Figure 3. Replacement of Battery**

### 3. Selection of Units of Measurement (lx, fc)

Since this illuminance meter conforms to the International System of Units (SI units), the lux (lx) is regarded as the reference unit. Some countries use the footcandle (fc) which is not an SI unit. For this reason, this illuminance meter provides a function to display readings converted to fc units with a unit selector switch. Select the desired unit, as needed, prior to measurement.

Be sure to turn off the power before selection.

Figure 4 shows the location of the lx-fc selector switch. Note that the specifications and operation description in this manual are based on the lux.

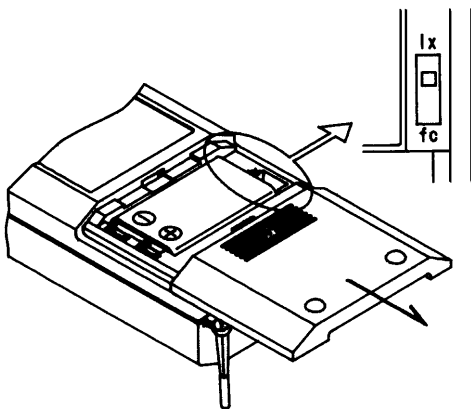

**Figure 4. Location of lx-fc Selector Switch**

### 4. Automatic Power Off (AUTO POWER OFF)

This digital illuminance meter provides an automatic power-off function in order to avoid using up the battery if you forget to turn off the power. This function turns the power off about 30 minutes after any key is last pressed. Immediately before turning the power off, the meter makes a beeping sound. If you press any of the operation keys while the beeping sound is on, this will extend the time of the automatic power-off function by 30 minutes. Whenever a plug is in the recorder output connector while the

totalized intensity of illumination and/or the comparator function is being executed, this function is automatically disabled; thus, it does not function. The function can be disabled permanently if not necessary (if the meter is used continuously). Refer to the operation procedure described in “Illuminance Measurement.” Whenever this function is operable, [AUTO POWER OFF] appears in the display area.

#### Notice on Making Measurements

1. Before starting measurement, as a rule, turn on the bulb five minutes beforehand and the discharge lamp 30 minutes.
2. Set the position and angle of the light-detecting surface accurately. Figure 5 shows the measuring reference plane.

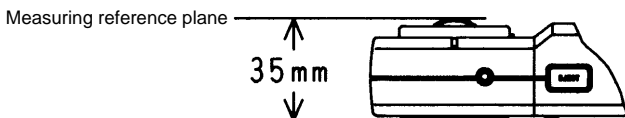

**Figure 5. Measuring Reference Plane**

3. Exercise care that your position or clothes do not affect illuminance measurement.
4. In the case of accurate illuminance measurement, multiply the measured value by the color correction factor corresponding to the spectral distribution of the measuring light source and the factor corresponding to the relative spectral response of this illuminance meter, respectively. This meter provides a color correction factor function which is set to a typical light source. The color correction factor multiplied by the measured value is indicated automatically.
5. The zero point may vary if the ambient temperature varies greatly over long-time meter use. In such a case, turn off the power once and then turn it on again (see “Illuminance Measurement”).

Light source type	Color correction factor* Typical value of
Daylight fluorescent lamp	0.994
White fluorescent lamp	0.996
Three-way fluorescent lamp	1.007
High-pressure mercury vapor lamp	0.993
High-pressure sodium vapor lamp	0.988
Standard light source B	0.996
Standard light source C	0.995
Equal-energy source (400 to 760 nm)	0.997

\*The color correction factor is calculated based on the relative spectral distribution values respectively of JIS Z 8719, JIS Z 8720, and CIE No. 53TC.2 lamps.

**Table 1. Typical Values of Color Correction Factor**

**Note**

- An electromagnetic interference affects the operating tolerances under EN61326-1;1997+A1;1998 condition.
- If a high electromagnetic interference equipment exists in the near vicinity of the instrument, this may cause malfunction.

## Illuminance Measurement

### Operation

1. Cover the light-detecting surface with the cap and confirm that the **[HOLD]** switch lock is released.
2. Press the **[POWER]** switch to turn on the power. All the characters will appear in the display area. When the meter enters the automatic zero-adjustment mode, [—CAL—] appears.

Note: If [—CAP—] appears, this means that the cap is not on properly. Press on the cap until [—CAL—] appears.

- When automatic zero adjustment is completed, [—CAL—] disappears and [0.0] appears.
- After confirming the [0.0] display, remove the cap to start measurement.
- After the measurement has been completed, press the **POWER** switch again to turn off the power, and cover the light-detecting surface with the cap for protection against stray light.

Note: If [Err] appears, check the connection between the main unit and light-detecting surface and check the cap to make sure it is on properly, and then start this operation again from the beginning. To disable the automatic power-off function, press the **HOLD** switch to lock the switch before turning off the power. When automatic zero adjustment is completed, press the **HOLD** switch to release the lock. [AUTO POWER OFF] disappears, resulting in automatic power-off being disabled.

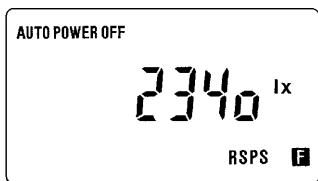

**Figure 6. Example of Display upon Illuminance Measurement**

### **Data Hold **HOLD** Switch**

This function holds (locks) the measured value indicated. This switch is used when it is hard to read an indication, such as measurement in a dark place.

#### **Operation**

- Press the **HOLD** switch (lock). The measured value is held (locked) and **D-H** appears.

2. Read the indication, taking the meter to a bright place or turning on a light in the room.
3. To release the lock, press the **HOLD** switch again. This causes **D-H** to disappear.

### **Timer Hold** **HOLD** Switch, **T-H** Key

This function holds the measured value after a time set in advance has elapsed. You must move away from the place where the meter is located so that your position or clothes do not have an influence on the measurement. Setting and holding the time so you may leave the area enable accurate measurement. The data are held (locked) after five seconds have elapsed.

#### Operation

1. Press the **HOLD** switch (lock). This causes **D-H** to appear.
2. Press the **T-H** key to start the timer; **D-H** starts blinking.
3. Move away from the place where the meter is located.
4. When five seconds elapse, a beeping sound is generated, **D-H** stops blinking, and the measured value at that time is held (locked).
5. Read the indicated value.
6. To release the lock, press the **HOLD** switch again. This causes **D-H** to disappear.
7. To repeat this operation, do items 2 to 5 or 1 to 6.

### **Range Hold** **RANGE** Key

This key selects automatic range and manual range. Manual range enables an arbitrarily fixed range to be set. If measured values are known to be within a particular range response comes fast if a fixed range is used, making reading much easier.

The range configuration is as follows:

0.0 to 99.9  
0 to 999  
00 to 9,990  
000 to 99,900  
0,000 to 999,000

o: dummy display (The o or o's indicate the number of digits)

## Operation

1. Press the **RANGE** key to switch manual range; its range is fixed to the currently executing range. This causes [R-H] to appear.
2. Each time this key is pressed, the range becomes maximized subsequently. After the display reaches the most significant range, it returns to the least significant range, and repeats such action.

Note: To confirm the range, cover the light-detecting surface with the cap to make the luminous intensity zero.

3. When the display shows the setting range, stop this key operation.
4. Keep pressing this key for two seconds to return to automatic range.

## Deviation Display **$\Delta/\%$** Key

This key is the deviation display function. The deviation is displayed by setting the reference luminous intensity and calculating the deviation to the set reference value. The display is twofold:

- (1) Deviation value display  $\Delta$

$$\Delta = (\text{measured value}) - (\text{reference value})$$

- (2) Percent display

$$\% = (\Delta/\text{reference value}) \times 100$$

## Operation

1. Measure the reference luminous intensity and then press the  $\boxed{\Delta/\%}$  key. The measured value at that time is retained in memory as a reference value. This causes  $[\Delta, R-H]$  to appear and the measured range is fixed. After that, the deviation value is displayed.
2. Press the  $[\Delta/\%]$  key again to change to the percent display. This causes  $[\%]$  to appear. Each time this key is pressed, these two appear alternately.
3. To confirm the reference value, keep pressing the  $\boxed{CALL}$  key.
4. To release, press the  $\boxed{\Delta/\%}$  key for two seconds.

Note: If the measured value exceeds the measuring range,  $[OL]$  appears.



## Data Output

Digital data output and comparator output can be transferred out through the data output connector. The output data are illuminance measurement data, which are transmitted as BCD serial data conforming to our standard format.

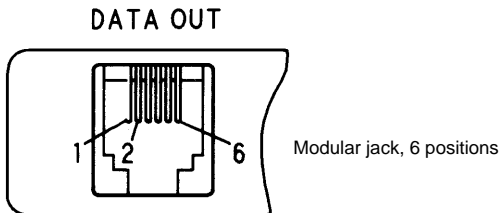

**Figure 7. Connector Pin Arrangement**

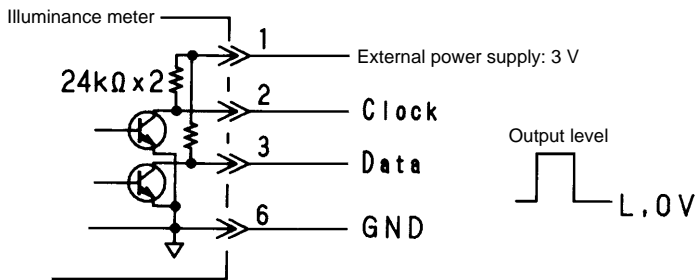

**Figure 8. Connection Circuit**

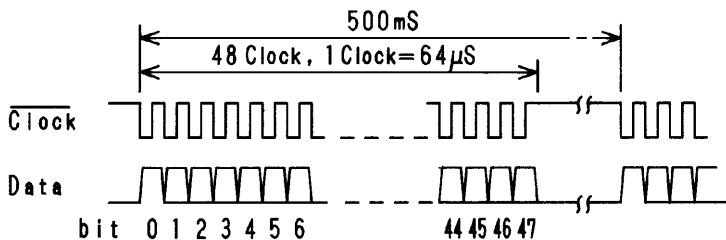

Figure 9. Timing Chart

Table 3. Contents of Data

Bit	Data	Bit Output	Bit	Data	Bit Output	
0	Start bit	H	24	Measurement data $10^1$ 8		
1	Measurement data overflow		25		4	
2	Function-setting data hold		26		2	
3	Measurement data sign (-)		27		1	
4	Error		28	Measurement data $10^0$ 8		
5	Lo batt (low battery voltage)		29		4	
6	Data length (48 bits)	L	30		2	
7		L	31		1	
8	Model code (illuminance meter)	L	32	Unused	L	
9		L	33		L	
10		H	34		L	
11		H	35		L	
12	Measurement data decimal point	dp1	36		L	
13		dp2	37		L	
14		dp3	38		L	
15	Unused	L	39		L	
16	Unused	L	40	Measurement data exponent	$10^{-6}$	
17		L	41		$10^{-3}$	
18		L	42		$10^{-3}$	
19		L	43		$10^{-6}$	
20	Measurement data $10^2$ 8		44	Display of unit lx		
21	4		45	Unused	L	
22	2		46		L	
23	1		47		L	

The levels of L and H in bit output are fixed.

Note

- The application of this accessory could affect the immunity performance of the product and such items should be used with this consideration.
- Interconnection with other apparatus is not recommended.

## Recorder Output (Analog Output)

Recorder output is connected to observation equipment (recorder, oscilloscope, etc.), and records of illuminance variation or a light source waveform can be observed.

Specifications:  $999\text{mV} \pm 5\%$  (range fixed for full scale of each range) Load resistance of  $100\text{ k}\Omega$  or more

1. Prepare a coated single-core shielded wire and solder it to the attached recorder output plug as shown in Figure 10. Connect another shielded wire to the input connector of the observation equipment.

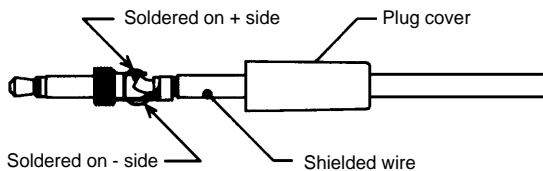

**Figure 10. Shielded Wire Connection Diagram**

2. Turn on the power to the illuminance meter and insert the plug into the recorder output connector of the light detector. The display [**REC**, R-H] appears, and the range is fixed (manual range).
3. Set the response selector switch to FAST.
4. The output voltage is 1 mV for one numeral of the least significant digit of the effective display (3 digits). Confirm the range according to the illuminance-measuring range. Use the [**RANGE**] key for range setting.

Note: Refer to “Range Hold” for [**RANGE**] key operation.

5. Cover the light detector with the cap to adjust the zero level of the observation equipment.
6. Remove the cap from the light detector to start observation.

### Note

- The application of this accessory could affect the immunity performance of the product and such items should be used with this consideration.
- Interconnection with other apparatus is not recommended.

## Separation of Light Detector

This illuminance meter can be used with the light detector and main unit separated. Prepare a dedicated connection cable (an accessory sold separately).

1. Turn off the power.
2. Press the eject button and the release lock to separate the light detector from the main unit.
3. Insert the plug (the plug with the eject pins) of the connection cable into the main unit and confirm that the connection is locked.
4. Connect the other end of the connection cable (the plug with the YOKOGAWA logo) to the light detector and confirm that the detector is locked to the connector.
5. Turn on the power to start measurement.
6. To disconnect the connection cable, press the eject buttons both on the plug connected to the light detector and on the main unit to release the two locks.

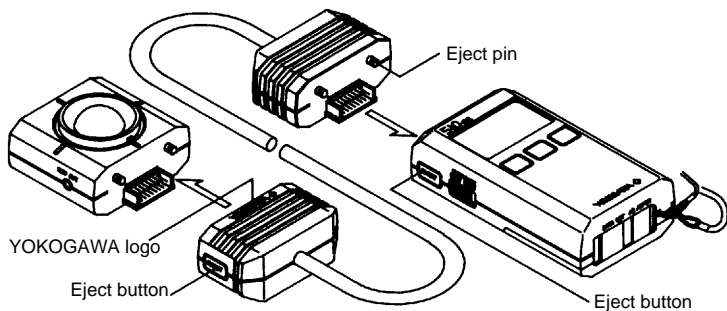

**Figure 11. Connection with Separated Light Detector**

### Note

- The application of this accessory could affect the immunity performance of the product and such items should be used with this consideration.
- Interconnection with other apparatus is not recommended.

## Use of AC Adaptor

In order to maintain correct operation, always use accessories (sold separately).

Model: 940 01

Rating: Input of 120 V  $\pm$ 10% AC  
Output of 9 V 100 mA DC

Model: 940 02

Rating: Input of 220 V  $\pm$ 10% AC  
Output of 9 V 100 mA DC

### Note

- The application of this accessory could affect the immunity performance of the product and such items should be used with this consideration.
- Interconnection with other apparatus is not recommended.

## After-sales Servicing

If repair work is necessary because of incorrect operation, consult the Yokogawa sales representative from whom you purchased the instrument or the Yokogawa sales division listed on the back of this manual.

## Error Message

When “Err.1” or “Err.2” message is indicated on the display, repair work is necessary.

## Specifications

Class:	Conformance to Class A in JIS C 1609-1: 2006
Photoelectric element:	Silicon photodiode
Display:	Liquid crystal display (numbers up to 7 digits); with function and unit display provided; maximum effective display: 999 + (0 or 0's to indicate the number of digit places) Overrange [OL] Low battery voltage [ $\text{E}$ ]
Measurement cycle:	Twice per second
Measuring ranges:	0.0 to 99.9/999/9,990/99,900/999,000 lx Automatic/manual selection of range
Accuracy:	At 23°C $\pm 2^\circ\text{C}$ If the reading is 3000 lx or less: $\pm 4\%$ of reading $\pm 1$ (effective minimum digit) If the reading is greater than 3000 lx: $\pm 6\%$ of reading $\pm 1$ (effective minimum digit)
Response time:	Automatic range: 5 sec max.; manual range: 2 sec max.
Characteristics of oblique incident light:	Angle of: $10^\circ \pm 1.5\%$ Deviation from the cosine law $30^\circ \pm 3\%$ $60^\circ \pm 10\%$ $80^\circ \pm 30\%$
Characteristics of relative visible-spectrum response:	Deviation from the standard spectrum luminous efficiency $f_s$ (JIS C 1609-1): within 9%
Temperature characteristics:	$\pm 5\%$ at 23°C reference and a range of -10 to 40°C
Humidity characteristics:	$\pm 3\%$
Recorder output:	1 V $\pm 5\%$ (fixed range, for each range) Load resistance: 100 k $\Omega$ or more
Automatic power-off:	Except when the integral function is working or the recorder (data) output plug is connected. After the last key has been pressed, the time set up for automatic power-off can be prolonged for approximately 30 minutes. This function can be disabled.

Operating temperature: Between -10 and 40°C  
Operating humidity: 80% R.H. or less; no moisture condensation  
EMC standards:

EN55011: 1998 Group 1 Class B  
EN61326-1; 1997+A1; 1998  
EN61000-3-2; 1995  
EN61000-3-3; 1995

Effect of radiation immunity:

Accuracy range of reading:  
[Rated accuracy+10% of range] for the strength of  
a radio-frequency electromagnetic field of 3V/m

Power supply: 9-V dry cell battery 6F22 (S-006P)/6LR61 or an AC  
adaptor (optional)

Dimensions: Approx. 67 (W) x 177 (H) x 38 (D) mm

Weight: Approx. 260 g

**Note**

If a high electromagnetic interference equipment exists in the near vicinity of  
the instrument, this may cause malfunction.

## Characteristics of Relative Visible-spectrum Response

The visible spectrum of light to which human beings are considered sensitive has an extremely narrow range: 360 to 830 nm. Within this range, sensitivity differs greatly depending on the wavelength. This phenomenon is called standard spectrum luminous efficiency, indicated by  $V(\lambda)$ . An illuminance meter is used to measure the luminous intensity, and the characteristics of relative visible-spectrum response plays an important role in illuminance measurement. This meter, rather than the human eye, brings these characteristics to the same degree of brightness as  $V(\lambda)$ .



These characteristics are standardized to the engineering standards of a legally certified luxmeter and to JIS C 1609 standards. The relative spectrum response of an illuminance meter  $S(\lambda)$  is measured in 95 wavelengths at 5-nm intervals to calculate the deviation from  $V(\lambda)$  (fs). This method of evaluation adopts the performance evaluation of the Commission Internationale de l'Eclairage (International Commission on Illumination) (CIE). Moreover, there are various light sources such as white light, fluorescent lamps, mercury-vapor lamps, and others on the market. The ideal would be for the relative spectrum response of the illuminance meter and  $V(\lambda)$  to match absolutely; however, there is a subtle deviation between them. Thus, a subtle indication error occurs if the illuminance of a light source having a different spectrum distribution from that upon calibration is measured. To correct this error, color correction factors are provided. To make an accurate measurement, it is recommended that color be corrected by multiplying the color correction factor of the measuring light source by the indicated value on the illuminance meter. Figure 12 shows the characteristics of the relative spectrum response:

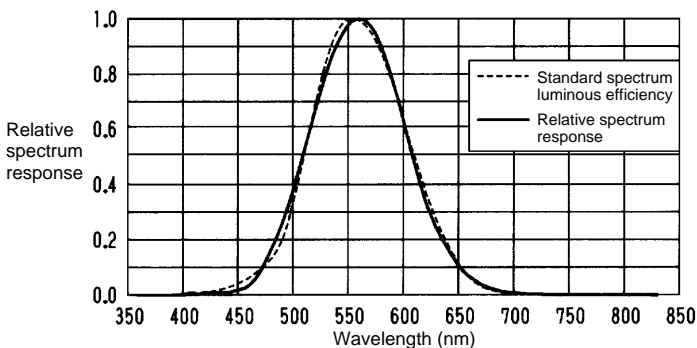

**Figure 12. Characteristics of Relative Visible-spectrum Response**

## Characteristic of Oblique Incident Light

When reading a book at night, you will find that the brightness differs between reading under a lamp or light and reading a little farther from the light. At that time, you can see that the words are more legible if you turn the book toward the light. Oblique incident light has the characteristic that when the angle between the tangential line of an illuminated surface and the direction of incidence is supposed to be  $\theta$ , the illuminance of the surface is proportional to  $\cos \theta$ . This characteristic is also standardized. If the cosine law did not hold true, the intensity of illumination from a light source in an oblique direction could not be measured accurately. Figure 13 shows the characteristic of oblique incident light.

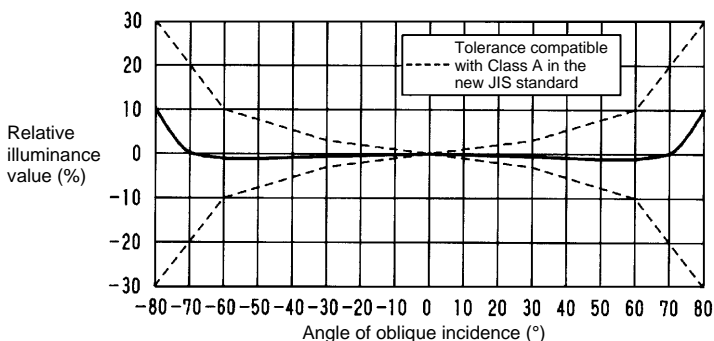

**Figure 13. Characteristic of Oblique Incident Light**

# Illuminance Measurements for Lighting Installations

(Extract from JIS C 7612 standards)

For general lighting, the horizontal angle of light shall be measured to obtain an average value. Unless otherwise specified, the height of the measuring surface shall be within 85 cm from the floor, 40 cm from the tatami floor in the case of a Japanese-style room, or nearly on the surface of the floor or ground in the case of a corridor or the outdoors (If it is difficult to measure the illuminance on the floor or ground, the height shall be within 15 cm from the floor or ground).

The location for measurement shall be divided into equal areas by vertical and horizontal partitioning lines, and the average illuminance for each area shall be calculated. The calculated average of the areas shall be the average illuminance of the total area measured. According to the 5-point method given in Figure 14, the middle of each side (the m point) and the center of gravity (the g point) shall be measured to obtain the average illuminance for each area according to the following expression:

$$\bar{E}_0 = \frac{1}{6} (E_{m1} + E_{m2} + E_{m3} + E_{m4} + 2E_g) = \frac{1}{6} (\sum E_m + 2E_g)$$

If the variation of the illuminance is small, the illuminance may be measured according to the 4-point method given in Figure 15 after measuring the illuminance ( $E_i$ ) of the four corners (the i point):

$$\bar{E}_0 = \frac{1}{4} (E_{i1} + E_{i2} + E_{i3} + E_{i4}) = \frac{1}{4} \sum E_i$$

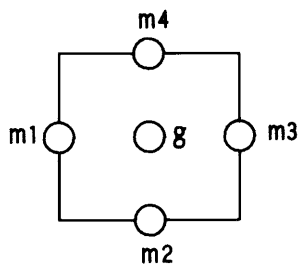

$$\bar{E}_0 = \frac{1}{6} (\sum^4 E_m + 2E_g)$$

**Figure 14. 5-point Method**

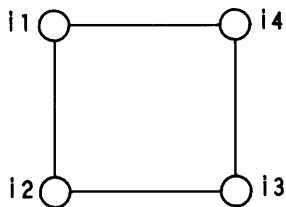

$$\bar{E}_0 = \frac{1}{4} \sum^4 E_i$$

**Figure 15. 4-point Method**

Also there is the method where the average illuminance of multiple divided areas is obtained directly. For details, refer to JIS C 7612.

MEMO

## Waste Electrical and Electronic Equipment (WEEE), Directive 2002/96/EC

This Product complies with the WEEE Directive (2002/96/EC) marking requirement. The affixed product label (see below) indicates that you must not discard this electrical/electronic product in domestic household waste.

### **Product Category**

With reference to the equipment types in the WEEE directive Annex 1, this product is classified as a “Monitoring and Control instrumentation” product.

To return unwanted products within the EU area, contact your local Yokogawa Europe B. V. office.

Do not dispose in domestic household waste.



# YOKOGAWA

Yokogawa Meters & Instruments Corporation

---

## Yokogawa Meters & Instruments Corporation

### International Sales Dept.

Tachihi Bld. No.2, 6-1-3, Sakaecho, Tachikawa-shi, Tokyo 190-8586 Japan  
Phone: 81-42-534-1413, Facsimile: 81-42-534-1426

### YOKOGAWA CORPORATION OF AMERICA (U.S.A.)

Phone: 1-770-253-7000 Facsimile: 1-770-251-2088

### YOKOGAWA EUROPE B. V. (THE NETHERLANDS)

Phone: 31-334-64-1611 Facsimile: 31-334-64-1610

### YOKOGAWA ENGINEERING ASIA PTE. LTD. (SINGAPORE)

Phone: 65-6241-9933 Facsimile: 65-6241-2606

### YOKOGAWA AMERICA DO SUL S. A. (BRAZIL)

Phone: 55-11-5681-2400 Facsimile: 55-11-5681-1274

### YOKOGAWA MEASURING INSTRUMENTS KOREA CORPORATION (KOREA)

Phone: 82-2-551-0660 to -0664 Facsimile: 82-2-551-0665

### YOKOGAWA AUSTRALIA PTY. LTD. (AUSTRALIA)

Phone: 61-2-9805-0699 Facsimile: 61-2-9888-1844

### YOKOGAWA INDIA LTD. (INDIA)

Phone: 91-80-4158-6000 Facsimile: 91-80-2852-1441

### YOKOGAWA SHANGHAI TRADING CO., LTD. (CHINA)

Phone: 86-21-6880-8107 Facsimile: 86-21-6880-4987

### YOKOGAWA MIDDLE EAST E. C. (BAHRAIN)

Phone: 973-358100 Facsimile: 973-336100

### LTD. YOKOGAWA ELECTRIC (RUSSIAN FEDERATION)

Phone: 7-095-737-7868 Facsimile: 7-095-737-7869