

## NORBAR TORQUE TOOLS PTM DUAL TRIGGER

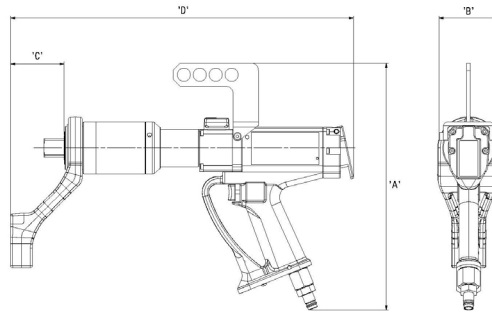

### PNEUTORQUE® PTM DUAL TRIGGER

- A second trigger located on the back plate requires the operator to use both hands to operate the tool and so reduces the risk of the operators' hands getting trapped between the reaction bar and reaction point
- Fast operation for rapid bolt rundown
- Non impacting - low vibration levels make these tools comfortable and safe to use
- Quiet - less than 85 db(A) when under load
- For safety, gearbox can rotate independently from the handle so that reaction forces are not transmitted back to the operator



PART NUMBER	MODEL	SQUARE DRIVE	RANGE		TOOL SPEED	DIMENSIONS (mm)				WEIGHT (kg)	
			N·m	lbf·ft		A	B	C	D	TOOL	REACTION
18100.B06.DT	PTM-52-500-B-DT	¾"	100-500	74-370	224	341	82	60	363	4.25	0.85
18101.B06.DT	PTM-52-800-B-DT	¾"	160-800	118-590	148	341	82	60	363	4.25	0.85
18102.B06.DT	PTM-72-1000-B-DT	¾"	200-1000	147-738	122	341	85.7	75	395	6.25	0.7
18103.B08.DT	PTM-72-1350-B-DT	1"	270-1350	200-1000	86	341	85.7	75	395	6.25	0.7
18104.B08.DT	PTM-72-2000-B-DT	1"	400-2000	295-1475	58	341	85.7	75	428	6.65	0.7
18106.B08.DT	PTM-92-2700-B-DT	1"	540-2700	400-2000	46	341	92	98.5	454	8.65	1.35
18119.B08.DT	PTM-92-4000-B-DT	1"	800-4000	590-2950	32	341	92	98.5	454	8.65	1.35
18119.B12.DT	PTM-92-4000-B-DT	1½"	800-4000	590-2950	32	341	92	98.5	454	8.65	1.35
18108.B12.DT	PTM-119-4500-B-DT	1½"	900-4500	660-3300	23	341	119	127	486	13.45	2.1
18109.B12.DT	PTM-119-6000-B-DT	1½"	1200-6000	885-4500	15.5	341	119	127	486	13.45	2.1

**NOTE:** The Dual Trigger handle can be applied to other PTM tools. Please contact Norbar with your requirements.



For more details on all Norbar products please contact:

**NORBAR TORQUE TOOLS LTD**

Beaumont Road, Banbury,  
Oxfordshire OX16 1XJ

UNITED KINGDOM

Tel + 44 (0)1295 753600

Email [enquiry@norbar.com](mailto:enquiry@norbar.com)