

INTERBUS

Quick Start Guide

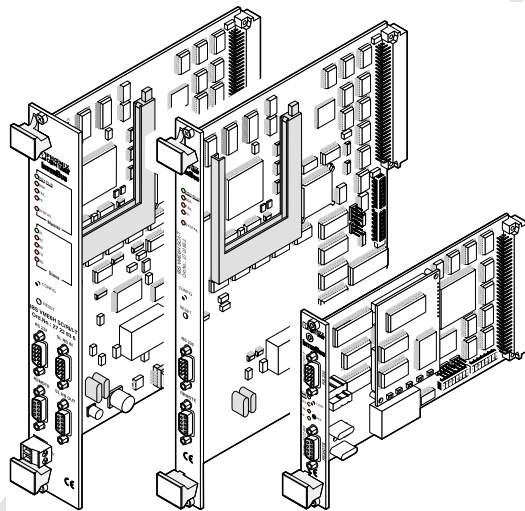

Designation: IBS VME SC QS UM E

Revision: BC01

Order No.: 27 45 95 2

This guide is valid for:

IBS VME3H SC/I-T	As of revision 13/442
IBS VME6H SC/I-T	As of revision 13/442
IBS VME6H SC/RI/I-T	As of revision 13/442

Table 1 Technical data for VMEbus controller boards

	IBS VME3H SC/I-T	IBS VME6H SC/I-T	IBS VME6H SC/R/I-T
INTERBUS Data:			
Sensors and actuators		Up to 4096	
INTERBUS devices		Up to 512	
Remote bus devices		Up to 254	
PCP devices		Up to 62	
Visual Diagnostics:		Operating and error states via LEDs	



The slave coupling of the IBS VME6H SC/R/I-T system coupler to the higher-level host system can be set with a maximum data width of 10 words of inputs and outputs (160 I/O). The setting is made using IBS CMD SWT G4 E configuration software.

Application Areas/Technical Data

The IBS VME3H SC/I-T controller board is compatible with 3U VMEbus systems. The controller boards IBS VME6H SC/I-T and IBS VME6H SC/R/I-T are compatible with 6U VMEbus systems.

Table 1 Technical data of the VMEbus controller boards

	IBS VME3H SC/I-T	IBS VME6H SC/I-T	IBS VME6H SC/R/I-T
Mechanical Structure:			
Space required in the control system	1 slot	1 slot	2 slots
Weight	230 g	290 g	370 g
Air and creepance distances	VDE 0110-1, 01/89, VDE 0160, 05/88		
Permissible operating temperature	From 0°C to +55°C (32°F to 131°F)		
Permissible storage temperature	From -25 °C to +85 °C (-13°F to 185°F)		
Data Interfaces:			
Connector	System connector to the backplane of the control system (C96 connector according to DIN 41612)		

Table 1 Technical data of the VMEbus controller boards

	IBS VME3H SC/I-T	IBS VME6H SC/I-T	IBS VME6H SC/RI/I-T
INTERBUS interface	9-pos. D-SUB female connector for the remote bus (REMOTE)		
Diagnostic interface	9-pos. D-SUB male connector for diagnostics (RS-232)		
Supply, Master:			
Connection method	Via VMEbus connector P1		
Operating voltage, master	+5 V DC (ripple 0.1 V _{pp})		
Power consumption, typical	2.75 W	3.1 W	3.1 W (5 V); 2.4 W (24 V)
Current consumption	550 mA	590 mA	610 mA
Supply, Slave:			
Connection method	--	--	Screw-clamp terminal (plug-in)
Operating voltage, slave	--	--	+ 24 V DC (ripple 0.5 V _{pp})
Power consumption, typical	--	--	3.1 W (5 V); 2.4 W (24 V)
Current consumption	--	--	100 mA

General Notes

Unless otherwise indicated, all information in this guide refers to the controller boards

- IBS VME3H SC/I-T, Order No. 27 22 86 5
- IBS VME6H SC/I-T, Order No. 27 22 85 2
- IBS VME6H SC/RI/I-T, Order No. 27 22 83 6

as of revision 13/442 (see sticker on the front plate of the controller board).

When using this guide, please observe the following notes:



The *attention* symbol refers to an operating procedure which, if not carefully followed, could result in damage to equipment or personal injury. The symbol is always located to the left of the tagged text.



The *note* symbol gives you tips and advice on hardware and software optimization. It also informs you of conditions that must strictly be observed to achieve error-free operation. The symbol is also used to clarify terms.



The *text* symbol refers you to detailed sources of information (manuals, data sheets, literature, etc.) on the subject matter, product, etc. This text also provides helpful information for the orientation in the manual.

Right and secure use of the product requires proper transport, storage, mounting and assembly as well as careful operation and installation. The use of this product is only permitted by qualified personnel authorized to start up, ground and mark devices, systems and electric circuits according to the standards of safety technology. Phoenix Contact assumes no liability for damage or personal injury resulting from disregard of notes and safety guidelines contained in this manual.

Please note that software/hardware designations and brand names of the companies mentioned are, as a rule, protected by copyright, trademark or patent.

Current product information is also available on the Internet at www.phoenixcontact.com.

onlinecomponents.com

Table of Contents

Application Areas/Technical Data	1
General Notes	1
Preface	3
Preparations	5
ESD Regulations	5
Unpacking the Controller Board	5
Connecting and Operating Elements	6
Preparing the Controller Board.....	13
Inserting the Memory Card.....	13
Setting the DIP Switches.....	14
Installing the Controller Board.....	22
Inserting the Controller Board Into the Control System.....	22
INTERBUS System Connection	25
Connecting the RS-232 Cable	26
Startup Without IBS CMD Configuration Software	27
Saving the Physical Configuration	28
Startup With IBS CMD Configuration Software ...	30
Creating a Configuration File for the IBS VME3H SC/I-T and IBS VME6H SC/I-T Controller Boards	31
Creating a Configuration File for the IBS VME6H SC/RI/I-T Controller Board	32
Activating the Stored Configuration.....	41
Linking the Driver Software to the Application Program.....	43

Table of Contents

Appendix	45
Replacing the Controller Board.....	45
Replacing the Memory Card	48
Firmware Update of the Controller Board	49
Connecting Cable	50

onlinecomponents.com

Preface

Application

This Quick Start Guide is designed to help you to start up and operate an INTERBUS system connected to an IBS VME6H SC/(RI)/I-T controller board for VMEbus systems.



For ease of use of this guide, the IBS VME6H SC/RI/I-T system coupler is from now on referred to as a controller board. Compared with traditional controller boards, system couplers have additional slave interfaces.

Purpose

This guide should make it possible to start up the INTERBUS system quickly and easily. Please refer to the enclosed manuals for a complete description of all the controller board features and a detailed description of all possible services and error messages.

Contents

This guide describes the easy startup of the INTERBUS system as follows:

1. Setting and installing the hardware
2. Testing the entire system
3. Configuring and loading system data to the parameterization memory
4. Controller board startup
5. Operation of the INTERBUS system
(diagnostic and operating functions are described in addition to startup.)

Hardware and Software Requirements

- Controller board
 - IBS VME3H SC/I-T Order No. 27 22 86 5
 - IBS VME6H SC/I-T Order No. 27 22 85 2
 - IBS VME6H SC/RI/I-T Order No. 27 22 83 6
- Memory card (optional)
 - IBS MC FLASH Order No. 27 51 77 1
- RS-232 cable for connecting controller board and PC
 - IBS PRG CAB Order No. 28 06 86 2
- Driver software for OS/9
(Part of the IBS VME SC OS9 UM E binder)
- Configuration software
 - IBS CMD SWT G4 E Order No. 27 21 44 2

Additional Documentation

-  INTERBUS Installation and I/O Systems Manual
IBS SYS PRO INST UM E Order No. 27 43 80 2

Preparations

This section contains the basic settings which are necessary before installing the controller board in the control system and which determine the operating behavior.

ESD Regulations



Persons who handle the controller board must protect it by observing the ESD instructions before packing or unpacking the board, opening control boxes or control cabinets and before touching the board.

Unpacking the Controller Board

The controller board is supplied in an ESD bag together with a package slip with installation instructions. Please read the complete installation instructions before unpacking the controller board.



Only qualified persons should pack, unpack and handle the controller board while observing the ESD instructions.

Connecting and Operating Elements

IBS VME3H SC/I-T

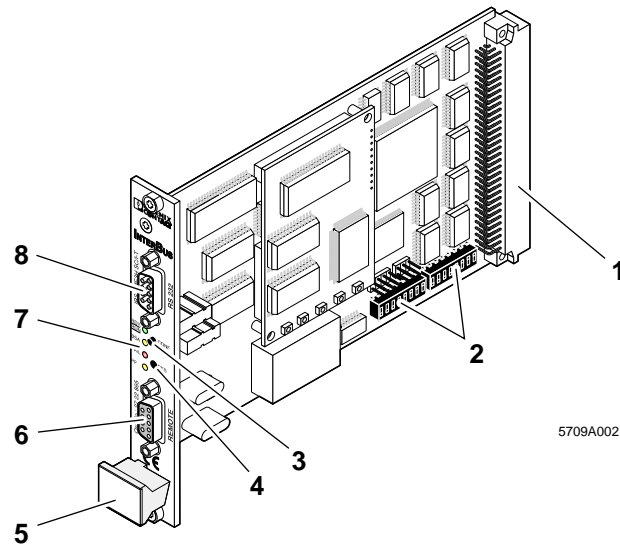

5709A002

Figure 1 Structure of the IBS VME3H SC/I-T controller board

Key:

1. System connector, VMEbus interface (P1 connector)
2. DIP switches
3. Configuration button
4. Reset button (can be disabled using DIP switches)
5. Ejector
6. Remote bus interface (9-pos. D-SUB female connector)
7. Diagnostic and operating indicators
8. Diagnostic interface (9-pos. D-SUB male connector)

IBS VME6H SC/I-T

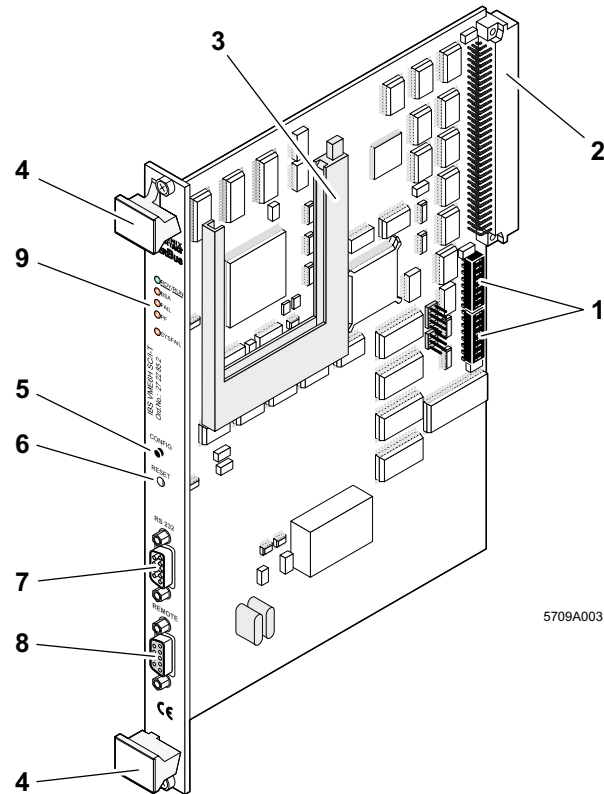

5709A003

Figure 2 Structure of the IBS VME6H SC/I-T controller board

Key:

1. DIP switches
2. System connector, VMEbus interface (P1 connector)
3. Card holder for the optional plug-in memory card (not supplied as standard with the controller board)
4. Ejector
5. Configuration button
6. Reset button (can be disabled using DIP switches)
7. Diagnostic interface (9-pos. D-SUB male connector)
8. Remote bus interface (9-pos. D-SUB female connector)
9. Diagnostic and operating indicators

IBS VME6H SC/R/I-T

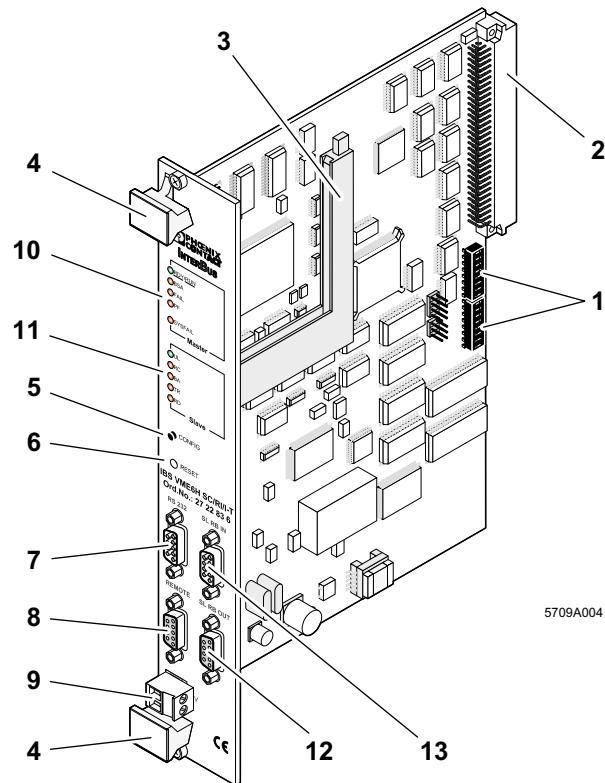

Figure 3 Structure of the IBS VME6H SC/R/I-T controller board

Key:

 Please refer to IBS VME6H SC/I-T for points 1 to 8.

- 9. 24 V DC supply voltage, slave
- 10. Diagnostic and operating indicators, master
- 11. Diagnostic and operating indicators, slave
- 12. Output interface, slave (9-pos. D-SUB male connector)
- 13. Input interface, slave (9-pos. D-SUB female connector)

Diagnostic Indicators

The diagnostic LEDs are used to indicate the operating and error states of the controller board.

IBS VME3H SC/I-T

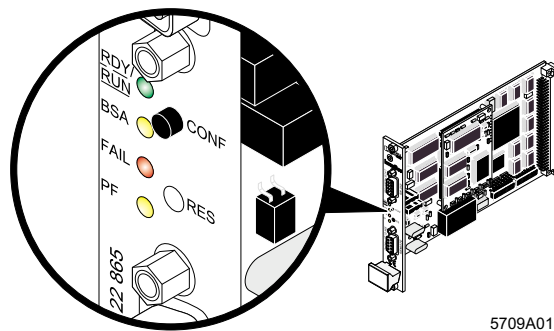

Figure 4 Diagnostic indicators on the IBS VME3H SC/I-T controller board

IBS VME6H SC/I-T

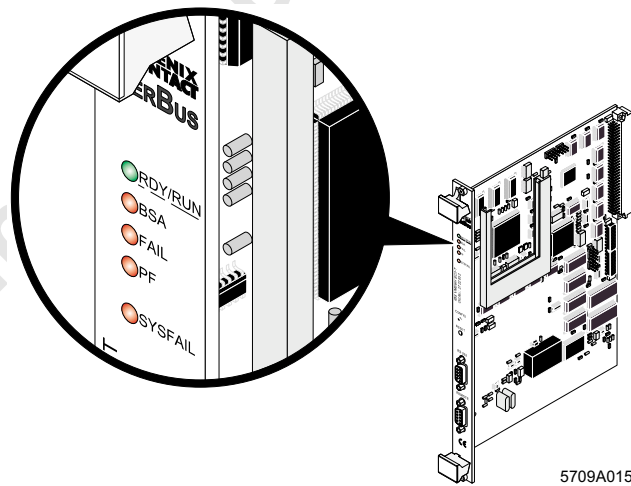

Figure 5 Diagnostic indicators on the IBS VME6H SC/I-T controller board

IBS VME6H SC/RI/I-T

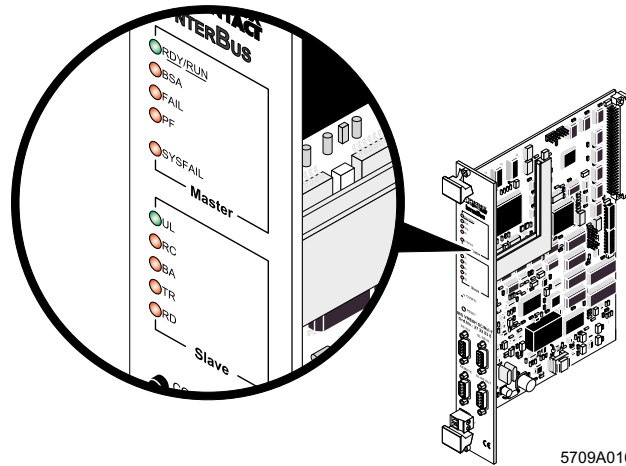



Figure 6 Diagnostic indicators on the IBS VME6H SC/RI/I-T controller board

Table 2 Descriptions of the diagnostic LEDs, **master**

LED	Description
RDY/RUN	INTERBUS ready to operate (LED flashing)/ INTERBUS active (LED permanently on)
BSA	Bus segment aborted (switched off)
FAIL	Bus error (remote bus/local bus)/controller board error/user error
PF	Peripheral fault
SYSFAIL	System error (only for IBS VME6H...)

Table 3 Descriptions of the diagnostic LEDs, **slave**
(only for IBS VME6H SC/RI/I-T)

LED	Description
UL	Operating voltage ON
RC	Remote bus cable check
BA	Bus active
TR	Data exchange with slave
RD	Remote bus disconnected

 For additional information about error messages, please refer to the IBS SYS DIAG DSC UM E Diagnostics Guide.

CONFIG and RESET Buttons

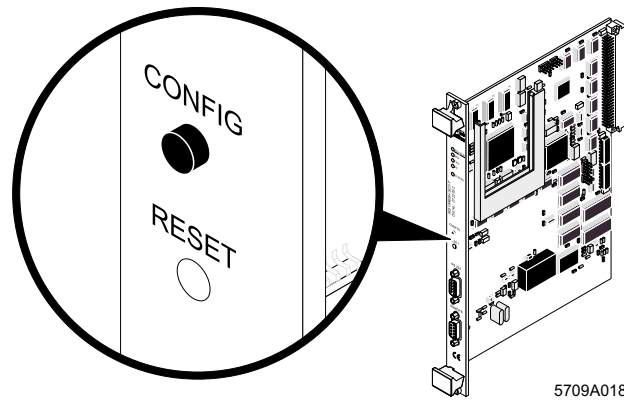

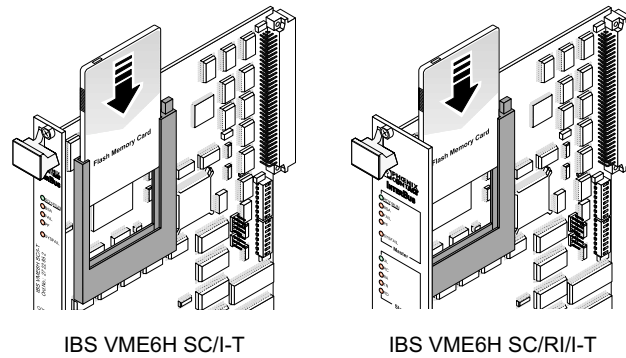

Figure 7 Controller board buttons

Use the CONFIG button to read the physically connected bus configuration (see also "Startup Without IBS CMD Configuration Software" on page 27).
Use the RESET button to reset the controller board.

 Figure 7 shows the IBS VME6H SC/I-T controller board as an example. It also applies to the controller boards IBS VME3H SC/I-T and IBS VME6H SC/R/I-T.

Card Holder for the Optional Plug-In Memory Card



IBS VME6H SC/I-T

IBS VME6H SC/RI/I-T

5709A005

Figure 8 Memory card holder

A system-specific parameterization of the INTERBUS system and the controller board are stored on the plug-in memory card.

- ☞ The memory card (IBS MC FLASH, Order No. 27 51 77 1) is not supplied as standard with the controller board.
- ☞ The IBS VME3H SC/I-T controller board has an internal (non plug-in) parameterization memory.

Preparing the Controller Board

Inserting the Memory Card

 The plug-in memory card can only be used for the IBS VME6H SC/I-T and IBS VME6H SC/RI/I-T controller boards.

The IBS VME3H SC/I-T controller board has an internal (non plug-in) parameterization memory.

The IBS MC FLASH memory card stores parameterization data of the INTERBUS system. The parameterization data is generated by the IBS CMD SWT G4 software tool or by the controller board itself. The plug-in memory card can be overwritten as often as you like and has been designed as a retentive memory.

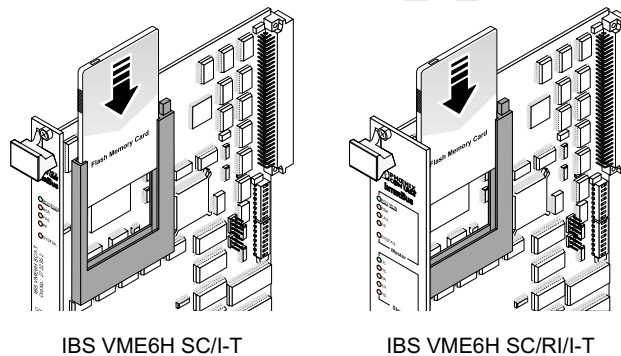

5709A005

Figure 9 Inserting the memory card

With the female connector going first, insert the memory card into the associated card holder. Make sure that when the memory card is pressed lightly the ejector moves outward and engages with a click.



As you insert the memory card, ensure that the card is located in the guide rails on both sides of the card holder. Make sure that the memory card is properly aligned!

Setting the DIP Switches

There are two DIP switch blocks (S1 and S2) located below the system connector of the controller board. These DIP switches allow you to set the base address and the operating mode (see Figure 1 to Figure 3).

If you place the IBS VME6H SC/I-T or IBS VME6H SC/RI/I-T controller board in front of you with the system connector on the top left, the switch positions will be identical to those shown in Figure 10. With the IBS VME3H SC/I-T controller board, the system connector should be on the right.

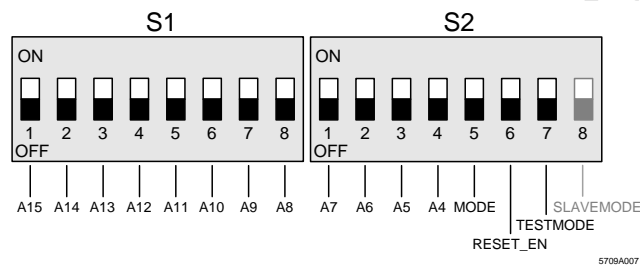

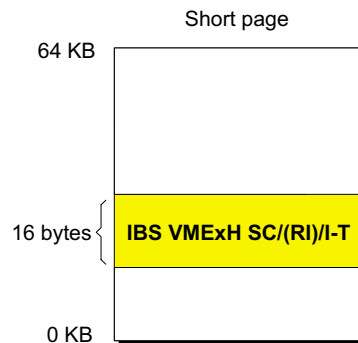

Figure 10 DIP switch positions

-  All switches are set to **OFF** by default.
-  Only with IBS VME6H SC/RI/I-T controller boards is it possible to operate switch 8 of S2 (**SLAVEMODE**) (see description on page 18).
For the IBS VME3H SC/I-T and IBS VME6H SC/I-T controller boards, switch 8 is reserved. Keep the switch in the **OFF** position.

Setting the Base Address

The controller board occupies 16 bytes in the short-page area of the VME system.



5709A006

Figure 11 Structure of the short-page window



For additional information on the short page, please refer to the IBS VME SC OS9 SWD UM E User Manual which is enclosed with the IBS VME SC OS9 UM E binder. If you have the IBS VME SC UM E binder, you do not require the information from the IBS VME SC OS9 SWD UM E User Manual.

The base address of the short-page register is set using DIP switches A4 through A15 (see also Figure 10, "DIP switch positions" on page 14):



If other I/O boards are used in the same rack, make sure that the addresses do not overlap within the short page!



Switches **5 through 8** of S2 have special functions! Please refer to the descriptions given on the next two pages for switch settings.

Setting the Operating Mode

MODE (Switch 5)

The **MODE** switch determines whether only the supervisor can access the short-page window (MODE = **OFF**) or whether user and supervisor can access it (MODE = **ON**).

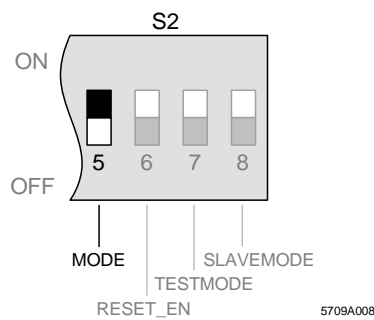



Figure 12 Setting the **MODE** switch

RESET_EN (Switch 6)

The **RESET_EN** switch activates the reset button located behind the front plate. The board can only be reset with this button if this switch is in the **ON** position (useful for lab operation).

 During normal system operation the **RESET_EN** switch should be set to **OFF**.

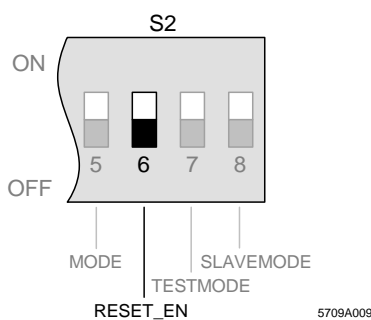

Figure 13 Setting the **RESET_EN** switch

TESTMODE (Switch 7)

If the **TESTMODE** switch is in the **ON** position, the controller board automatically changes to test mode with every power up of the control system or controller board reset. During the test phase (lab operation) the test mode of the board can be used to operate any INTERBUS test parameters and check the bus system operation.

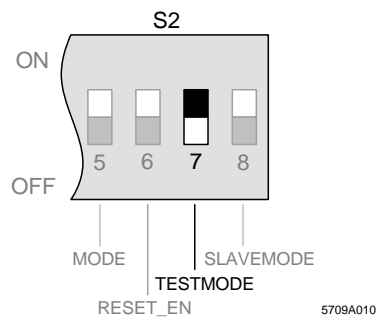

Figure 14 Setting the **TESTMODE** switch



If the test mode is active, I/O data cannot be transmitted between the control system and the controller board.



To return to normal operation, return the **TESTMODE** switch to the **OFF** position.

SLAVEMODE (Switch 8)

 Only with IBS VME6H SC/RI/I-T controller boards is it possible to operate the **SLAVEMODE** switch. In the case of the IBS VME3H SC/I-T and IBS VME6H C/I-T controller boards, switch 8 is reserved. Keep the switch in the **OFF** position.

On IBS VME6H SC/RI/I-T controller boards, switch 8 is used to set the operating mode after a reset or power up. In the **OFF** position, the PCP mode is activated on the system coupler. In this mode, the ID code EB_{hex} is set automatically. If the switch is in the **ON** position, the ID code 3_{hex} is set.

Table 4 States of the **SLAVEMODE** switch

Switch Position	ID Code	Parameter Channel	Process Data Channel
OFF	EB_{hex}	1 word	0 words
ON	3_{hex}	0 words	6 words

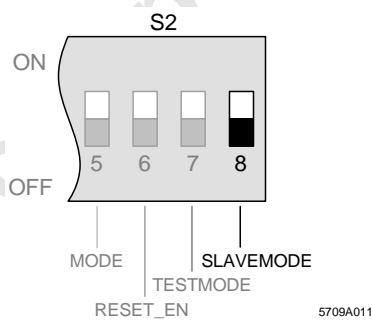



Figure 15 Setting the **SLAVEMODE** switch

The maximum data width of 10 I/O words can be set via the IBS CMD SWT G4 configuration software or the host system.

 For additional information, please refer to the IBS VME SC OS9 SWD UM E User Manual.

Startup Behavior of the IBS VME6H SC/RI/I-T Controller Board

The IBS VME6H SC/RI/I-T controller board has several configuration options. The startup behavior of the controller board is dependent on the type of configuration selected. The following information can be used to determine which startup behavior is most suitable for the application.

 Phoenix Contact recommends configuring the controller board using the IBS CMD SWT G4 software and storing it on the plug-in memory card (see also "Creating a Configuration File for the IBS VME6H SC/RI/I-T Controller Board" on page 32).

Advantages:

- Easy and flexible option for configuring the controller board
- Configuration can be transferred on replacement of the controller board by inserting the old memory card
- The startup sequence is identical for all operations (reset, power up, etc.)

The three main options for configuring the controller board are as follows:

1. CMD/Memory Card

The configuration file is generated using the IBS CMD SWT G4 E software and stored on the plug-in memory card. The controller board loads this configuration file on each reset or power up. The setting of the SLAVEMODE DIP switch is ignored in this case.



If the slave part of the controller board is supplied with voltage before switching on the lower-level VMEbus system, it is parameterized again.

2. CMD/Host System

The configuration is generated with IBS CMD SWT G4 and stored as a file in SVC format on the host system of the controller board. During startup of the entire system, the host system transmits the file automatically to the controller board.

 The ID code setting of the controller board in the configuration file must correspond to the setting of the SLAVEMODE DIP switch. Since the controller board detects no plug-in memory card, the ID code setting of the SLAVEMODE DIP switch is accepted. If another ID code is entered in the configuration file, the controller board is configured again using this ID code. This behavior triggers a configuration error to the higher-level host system.

3. CMD/Higher-Level Host System

The configuration is transmitted from the higher-level host system (see 2.) to the controller board. The ID code EB_{hex} (**OFF** position) must be set on the SLAVEMODE DIP switch of the controller board for this purpose. Normally, the ID code in the configuration file is configured with a process data coupling (maximum of 10 words). This means configuring the controller board again during operation of the higher-level host system, which leads to a bus error (RB). INTERBUS must be started up again by the host system with the current ID code of the controller board. If there are several controller boards with system coupler functions in the higher-level host system, they must be started up one after another.

 If the 24 V voltage supply for the slave part fails on a controller board during operation, this controller board also loses the initialization defined by the host system. It must be started up again by the higher-level host system.

In general, the following behavior applies to the IBS VME6H SC/R/I/I-T controller board if an error occurs:

Table 5 Behavior of the IBS VME6H SC/R/I/I-T controller board if an error occurs

Error	Effect on the Higher-Level Host System	Effect on the Lower-Level Bus System
Failure of the 24 V voltage supply for the slave part	Bus error (RB) reported with details of the controller board position	None, if nothing else is configured
Failure of the lower-level INTERBUS of the controller board	Peripheral fault (PF) reported with details of the controller board position	Lower-level bus system is switched off
Failure of the higher-level host system	Higher-level bus system is switched off	None, if nothing else is configured
Reset or power up of the controller board	Peripheral fault (PF) reported with details of the controller board position	Lower-level bus system is switched off and started up again corresponding to the selected startup behavior

Installing the Controller Board



Always disconnect the voltage supply of the VMEbus rack when inserting and removing the controller board. Otherwise, the controller board or the control system may be damaged.

Inserting the Controller Board Into the Control System



Check the DIP switch settings on the controller board after inserting the memory card (see "Setting the DIP Switches" on page 14). All switches are set to **OFF** by default.

When installing the controller board in the VMEbus rack, please observe the following instructions and Figure 16 on page 24:

1. Switch off the power supply of the control system.
2. Place the controller board in the guide rails of the control system.
3. Push the controller board into the rack with proper alignment until the system connector snaps into the backplane of the control system (A). Check for a good contact at the system connector and for firm seating of the controller board in the control system.
4. Once the latches are snapped in properly, fasten the controller board using the two screws (B).



The controller boards IBS VME3H SC/I-T and IBS VME6H SC/I-T occupy one slot in the control system.

The IBS VME6H SC/RI/I-T controller board occupies two slots in the control system.

The system connector on the backplane connects the controller board to the VME system.



In the case of the IBS VME6H SC/RI/I-T controller board, make sure that the 24 V DC power supply of the slave is applied before or at least at the same time as the 5 V DC power supply of the backplane of the control system. This should be ensured using an appropriate circuit device (e.g., timer). Otherwise, controller board configuration errors may occur relating to the higher-level control system.

onlinecomponents.com

OMC

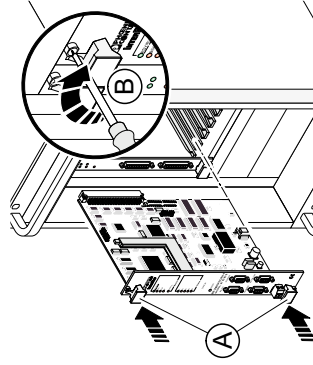

IBS VME6H SC/R/I-T

5709A012

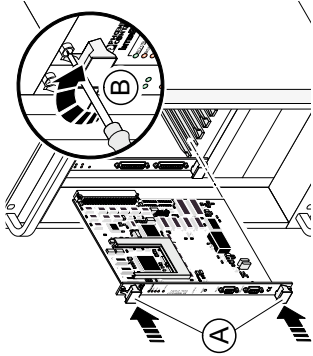

IBS VME6H SC/I-T

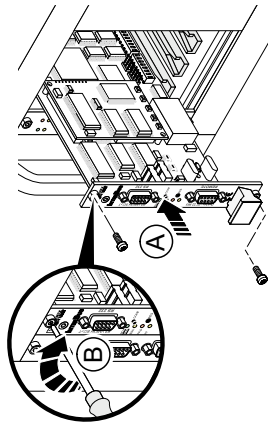

IBS VME3H SC/I-T

Figure 16 Installing the controller boards in the VMEbus rack

OMC

INTERBUS System Connection

Connect the remote bus cable which goes to the first INTERBUS bus terminal module (BK module) to the remote bus interface (REMOTE) on the controller board. The connection to the controller board is via a 9-pos. D-SUB female connector, into which you can insert either the remote bus cable or an adapter for conversion to fiber optic cable. For additional information on the bus cable assembly and fiber optic adapters, please refer to "Connecting Cable" on page 50.

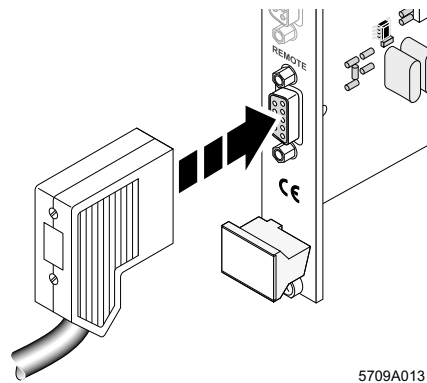

5709A013

Figure 17 Plugging in the remote bus cable
(here: IBS VME6H SC/I-T)

 In the case of the controller boards IBS VME3H SC/I-T and IBS VME6H SC/R/I/I-T, the remote bus cable is also plugged into the available REMOTE interface.

 Only use metal-plated connector housing. All Phoenix Contact connectors shown in this guide meet these requirements.

Connecting the RS-232 Cable

Connect the RS-232 cable to the diagnostic and parameterization interface (Designation RS-232) of the controller board. It connects the controller board and your PC (COM1 to COM4).

Connection

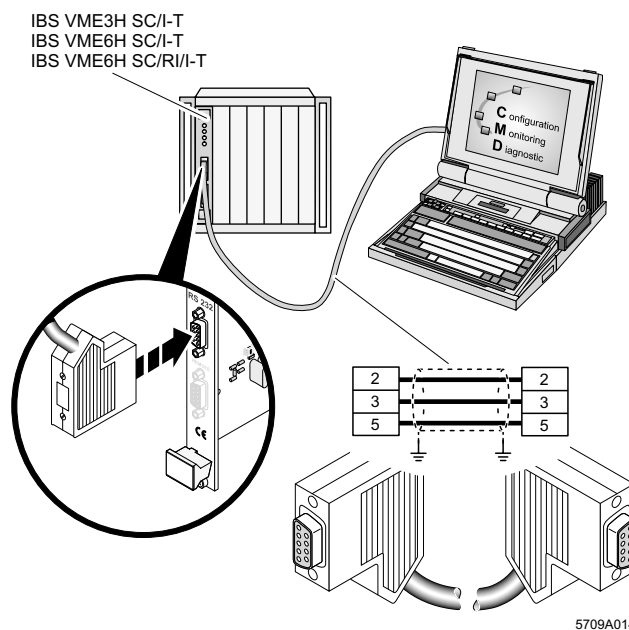



Figure 18 Cable connection between the PC and controller board

 RS-232 cable between the controller board and PC, length 3 m (9.843 ft.)

IBS PRG CAB



Order No. 28 06 86 2

 You can order the RS-232 cables described above as well as further types as pre-assembled cables from Phoenix Contact. Please contact your nearest Phoenix Contact representative.

Startup Without IBS CMD Configuration Software

 Unless otherwise indicated, the following information refers to each of the three controller boards.

The controller board offers an easy way to start up a small or predefined INTERBUS system (often lab operation) or to start up the entire system during the plant/machine installation phase, which does not demand any knowledge of the INTERBUS system. The currently connected INTERBUS configuration can be read in, addressed and stored on the plug-in memory card via the CONFIG button. Addressing depends on the physical position of the devices. By starting the module again, the entire system is started using the pre-configured data.

-  Any later change in the bus configuration causes the automatically configured host addresses to be shifted. Please consider how this will affect your application program.
-  Please check whether the connected configuration corresponds with the desired configuration. This can be carried out, e.g., using the IBS CMD SWT G4 configuration software.

Saving the Physical Configuration



Any configuration stored on the memory card will be overwritten.

1. Switch off the power supply of the control system.
2. Check whether the remote bus cable is connected with the REMOTE interface of the controller board.
3. Ensure that the memory card is plugged in and that write protection is **not** activated.
4. Ensure that the **TESTMODE** DIP switch is in the **OFF** position.
5. Switch on the power supply of the control system while pressing the CONFIG button.

The current bus configuration is now read in and stored on the memory card. This process is completed when the RDY/RUN LED is permanently on.

6. Switch off the control system power supply and then switch it on again.

If the connected bus system is activated by the controller board (RDY/RUN LED permanently on), the physical configuration is completed.



The configuration stored on the memory card is activated each time the controller board is reset. (Requirements: **TESTMODE** in the **OFF** position)



To prevent the parameterization from being overwritten, activate write protection on the plug-in memory card.

If an installation error prevents the system from starting normal operation, this is indicated by the LEDs located on the controller board.

Table 6 Descriptions of the diagnostic LEDs, **master**

LED	Description
RDY/RUN	INTERBUS ready to operate (LED flashing)/ INTERBUS active (LED permanently on)
BSA	Bus segment aborted (switched off)
FAIL	Bus error (remote bus/local bus)/controller board error/user error
PF	Peripheral fault
SYSFAIL	System error (only for IBS VME6H...)

Table 7 Descriptions of the diagnostic LEDs, **slave**
(only for IBS VME6H SC/RI/I-T)

LED	Description
UL	Operating voltage ON
RC	Remote bus cable check
BA	Bus active
TR	Data exchange with slave
RD	Remote bus disconnected



For additional error information, please refer to the "Firmware Services and Error Messages" User Manual, IBS SYS FW G4 UM E.

Startup With IBS CMD Configuration Software

In this section you will learn how to start up the INTERBUS system with the aid of the IBS CMD SWT G4 configuration software (referred to below as IBS CMD).

The aim is to illustrate the steps needed to set up and start INTERBUS operation on a controller board with IBS CMD in a logical sequence.



The online help or the IBS CMD SWT G4 UM E User Manual (Order No. 27 22 25 0) show you how to use IBS CMD.

Due to its slave function the IBS VME6H SC/RI/I-T controller board is to be considered separately for the startup with IBS CMD. The controller board configuration offers several options and depends on the corresponding application (see also "Startup Behavior of the IBS VME6H SC/RI/I-T Controller Board" on page 19). As a result, the section "Startup With IBS CMD Configuration Software" is divided into two parts:

- Creating a configuration file for the IBS VME3H SC/I-T and IBS VME6H SC/I-T controller boards
- Creating a configuration file for the IBS VME6H SC/RI/I-T controller board

The method of configuring and addressing INTERBUS devices is identical for the three controller boards. It is described following the controller board configuration.



The OUT data of the I/O coupling of the IBS VME6H SC/RI/I-T controller board is to be considered as IN data by the higher-level control system. Correspondingly, IN data of the I/O coupling is to be considered as OUT data.

Creating a Configuration File for the IBS VME3H SC/I-T and IBS VME6H SC/I-T Controller Boards

 The following steps are valid for CMD version 4.41 or higher.

Controller Board Configuration

1. Create a new project using IBS CMD.
2. Open the context menu of the controller board with the right mouse button and select "Type... Select Controller Board". Select one of the following two controller board types:
 - IBS VME3H SC/I-T
 - IBS VME6H SC/I-T

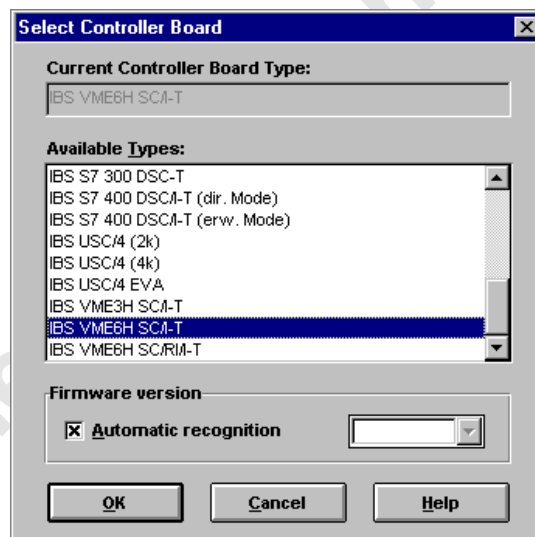



Figure 19 Selecting the controller board type

Configuration of INTERBUS Devices

To configure INTERBUS devices, please refer to page 39.

Creating a Configuration File for the IBS VME6H SC/RI/I-T Controller Board

 The following steps are valid for CMD version 4.41 or higher.

Controller Board Configuration

1. Create a new project using IBS CMD.
2. Open the context menu of the controller board with the right mouse button and select "Type... Select Controller Board". Select IBS VME6H SC/RI/I-T as the controller board type:

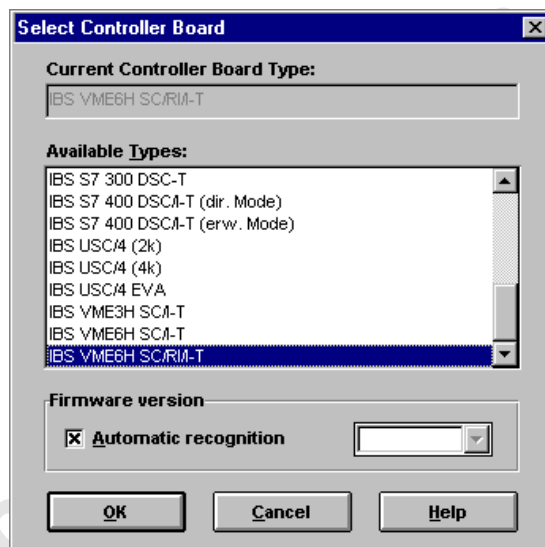



Figure 20 Selecting the controller board type

The further configuration of the controller board depends on your application.

The following configurations are possible:

- Dedicated process data coupling without lower-level bus
- Dedicated process data coupling with lower-level bus
- Process data and PCP coupling with lower-level bus

 Observe the notes on the startup behavior of the controller board in conjunction with the **SLAVEMODE** DIP switch on page 18.

Dedicated Process Data Coupling Without Lower-Level Bus

If no parameterization is stored on the controller board using the IBS CMD software, a data width of 96 bits (6 words in the I/O area), preset via the DIP switch, is initialized for process data coupling.

 For this, DIP switch 8 of S2 is to be set to ON (default setting: OFF; see also "Setting the SLAVEMODE switch" on page 18).

If another data width for the process data channel to the higher-level bus system is desired, proceed as follows:

1. Open the context menu of the controller board with the right mouse button.
2. In the "Controller Board Settings...I/O Coupling" dialog box, set the desired process data channel (e.g., data width 96 bits, see Figure 21).

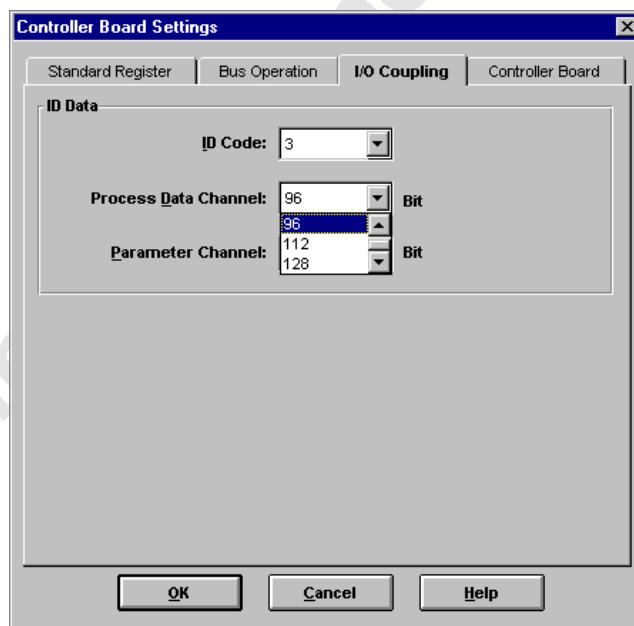

Figure 21 Setting the process data width

Some settings must now be made regarding parameterization:

1. Select "Parameterization... Edit" from the context menu of the controller board.
2. If no preprocessing has been programmed using IBS CMD, activate the "Boot" check box in the "Startup without PDP" parameterization.
3. Mark the "Startup without PDP" parameterization (line 2).
4. Activate the "Start Data Transmission" action in the "Startup without PDP" action sequence. Deactivate the "Active" check box.
5. Confirm the dialog box with "OK".

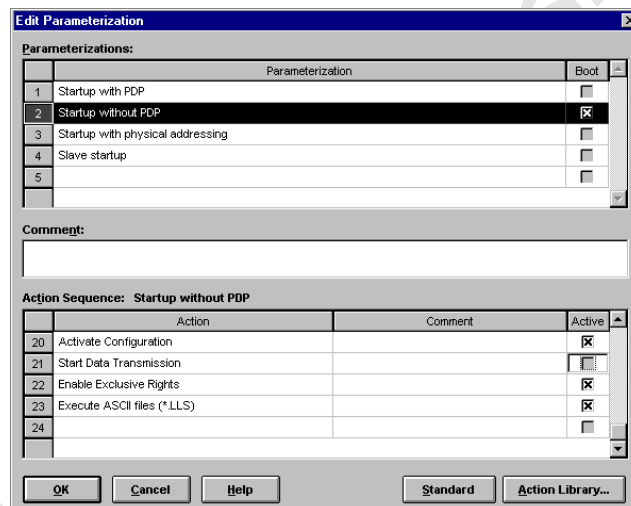



Figure 22 Editing parameterization

 Addresses must be assigned for the process data of the I/O coupling. To do this, open the process data dialog box and enter your chosen addresses. The online help or the IBS CMD SWT G4 UM E User Manual (Order No. 27 22 25 0) provide more details on how to use IBS CMD.

Configuration of INTERBUS Devices

To configure INTERBUS devices, please refer to page 39.

Dedicated Process Data Coupling With Lower-Level Bus

In the "Controller Board Settings...I/O Coupling" dialog box, set the desired process data channel (e.g., data width 96 bits, see Figure 23).

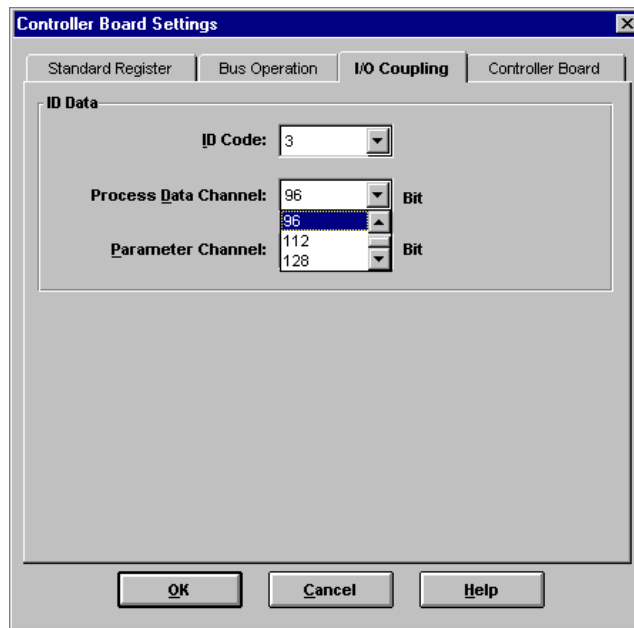



Figure 23 Setting the process data width

 Addresses must be assigned for the process data of the I/O coupling. To do this, open the process data dialog box and enter your chosen addresses. The online help or the IBS CMD SWT G4 UM E User Manual (Order No. 27 22 25 0) provide more details on how to use IBS CMD.

Configuration of INTERBUS Devices

To configure INTERBUS devices, please refer to page 39.

Process Data and PCP Coupling With Lower-Level Bus

The additional PCP coupling (parameter channel) can be used to directly access intelligent devices in the lower-level bus system from the higher-level control system using PCP communication.

1. Open the context menu of the controller board with the right mouse button.
2. In the "Controller Board Settings...I/O Coupling" dialog box, set the desired ID code in the "ID code" selection box.

 The set ID code determines the data width of the available parameter channel. The maximum total data width of the I/O coupling of the controller board to the higher-level control system is 160 bits (10 words). If, for example, a parameter channel of 32 bits is set, the process data channel can be set to 128 bits (8 words) maximum.

Please refer to the following table for possible settings of the parameter channel:

Table 8 Possible settings of the parameter channel

ID Code	Parameter Channel (Bits)	Process Data Channel, Maximum (Bits)
3	0	160
235	16	144
232	32	128
233	64	96

 A parameter channel with a width of 16 bits is normally sufficient.

 Addresses must be assigned for the process data of the I/O coupling. To do this, open the process data dialog box and enter your chosen addresses. The online help or the IBS CMD SWT G4 UM E User Manual (Order No. 27 22 25 0) provide more details on how to use IBS CMD.

3. Set the desired data width of the process data channel.

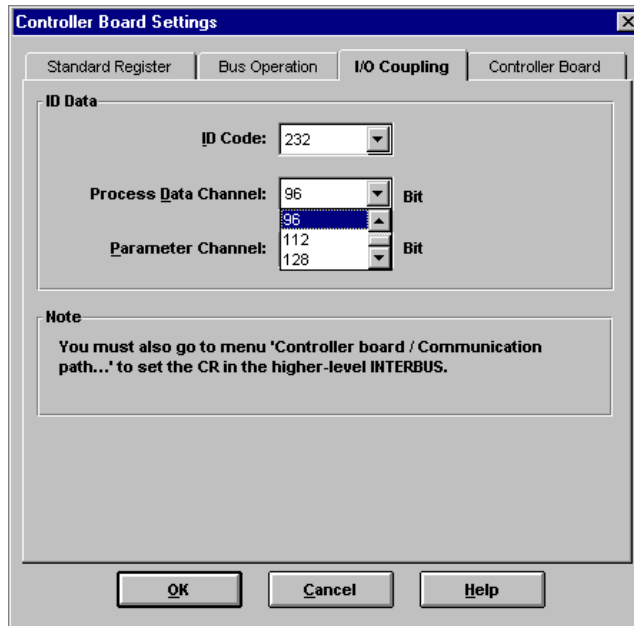

Figure 24 Setting the process data width

4. Confirm the dialog box and any following questions with OK.
5. Open the context menu of the controller board with the right mouse button and select "Communication Path...". This accesses the "Communication Path Settings" dialog box.
6. Determine the communication reference of the system coupler. Please proceed as follows:
 - Count all the PCP devices, including the system coupler, on the basis of their position in the higher-level bus system. The first PCP device in the bus is number 2, the second is 3, etc.
 - Then count all the system couplers of the higher-level bus system until you reach the required system coupler. The number you reach is the communication reference of the corresponding system coupler.



Explanation:

This is necessary because system couplers have two separate parameter channels. One PCP channel is used by the higher-level control system/computer system to access the PCP services of the system coupler. The other PCP channel is used by the higher-level control system/computer system to access the PCP services of the PCP devices in the lower-level bus system of the system coupler.

7. Activate the "Active" check box and select the determined communication reference for the system coupler in the "CR (Management Service)" selection box.

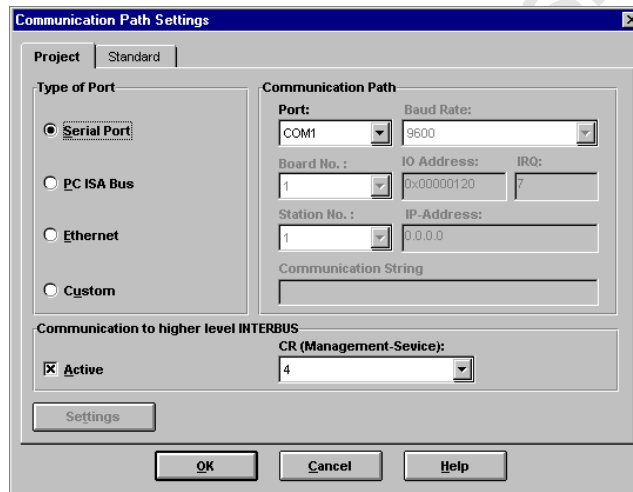

Figure 25 Setting the communication reference

8. Confirm the dialog box with "OK".

Configuration of INTERBUS Devices

There are two ways of configuring INTERBUS devices:

- IBS CMD reads in the connected bus structure, creates the complete configuration **automatically** and addresses all the INTERBUS devices.

Advantage: Highly simplified INTERBUS configuration, requiring little system knowledge.

Disadvantage: All the INTERBUS devices must be fully installed and powered up. Incorrectly connected devices (e.g., devices whose remote bus or local bus cable is not plugged in) will not be included. Due to physical addressing, later extensions to the plant (e.g., the addition of a new device) might require changes in the control program, as addresses in your application program will change.

- You generate the configuration yourself and allocate the addresses allowing for any existing software standards.

Advantage: You can optimize the system to meet your specifications or the structure of your control program. You can also reserve free addresses in the used I/O areas of the control system for later expansion of the system.

Disadvantage: The configuration requires greater effort.



The online help or the IBS CMD SWT G4 UM E User Manual (Order No. 27 22 25 0) provide additional information on how to configure INTERBUS devices using the IBS CMD software.

Please perform the following steps:

1. Address the INTERBUS devices. The addresses offered by CMD are offset addresses starting with the address you defined for the I/O data of the INTERBUS controller board in the standard address area of the VMEbus control system.

Example:

Offset in the standard address area: 1000_{hex}

Offset in CMD: 2_{dec}

→ Address in the standard address area: 1002_{hex}



Please note that the CMD offset addresses are assigned in decimal notation.

2. Check the configuration.
3. Save the configuration on the memory card.
4. Save the IBS CMD file on your local drive.



Addresses must be assigned for the process data of the I/O coupling. To do this, open the process data dialog box and enter your chosen addresses. The online help or the IBS CMD SWT G4 UM E User Manual (Order No. 27 22 25 0) provide more details on how to use IBS CMD.

Activating the Stored Configuration

Once the configuration has been saved successfully on the memory card, reset the controller board with IBS CMD or with a power up of the control system, in order to check the proper execution of the saved configuration.

When the stored configuration has been activated successfully, the READY/RUN LED on the controller board is permanently on.

If the system cannot be started successfully, this is indicated by the LEDs located on the controller board.

Table 9 Descriptions of the diagnostic LEDs, **master**

LED	Description
READY/RUN	INTERBUS ready to operate (LED flashing)/ INTERBUS active (LED permanently on)
BSA	Bus segment aborted (switched off)
FAIL	Bus error (remote bus/local bus)/controller board error/user error
PF	Peripheral fault
SYSFAIL	System error (not for IBS VME3H SC/I-T)

Table 10 Descriptions of the diagnostic LEDs, **slave**
(only for IBS VME6H SC/RI/I-T)

LED	Description
UL	Operating voltage ON
RC	Remote bus cable check
BA	Bus active
TR	Data exchange with slave
RD	Remote bus disconnected



For additional error information, please refer to the "Firmware Services and Error Messages" User Manual, IBS SYS FW G4 UM E.

When the INTERBUS system is activated, the defined inputs and outputs of the controller board become available. This completes the configuration and startup of the INTERBUS system. The input/output data transmitted over INTERBUS must now be transmitted to the application program.

 Save the configuration file on the memory card by activating write protection (slide switch on the memory card).

Saving the Configuration File on the Target System

With IBS CMD software, it is possible to export a created configuration file as a "svc" file. This file can be saved on the mass storage of the target system (as an alternative to storing the configuration file on the plug-in or internal parameterization memory). When starting the target system, this file is loaded through the "IB Loader Program" for INTERBUS configuration.

Linking the Driver Software to the Application Program

The supplied driver software disk allows you to easily use INTERBUS system functions and to transmit input and output data between the controller board and the application program.

 We recommend that you integrate INTERBUS controller boards into the VMEbus control system using this software. This will minimize the training period required and optimize the integration of INTERBUS and the control system.

 For a detailed description of the driver software, please refer to the IBS VME SC OS9 SWD UM E User Manual which is with the IBS VME SC OS9 UM E binder.

onlinecomponents.com

Appendix

Replacing the Controller Board

 Only qualified persons should pack, unpack and handle the controller board while observing the ESD instructions.

If it is necessary to replace the controller board, please note the following:

 The following example shows you how to replace the IBS VME6H SC/I-T controller board. This process also applies to all other controller boards.

1. Switch off the power supply of the control system.
2. Unplug the remote bus cable.

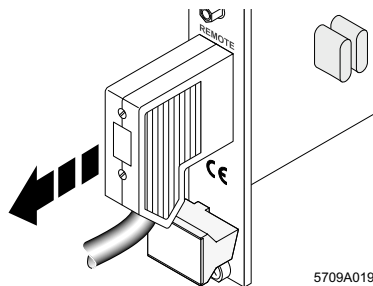

Figure 26 Unplugging the remote bus cable

3. Unplug the RS-232 cable, if installed.

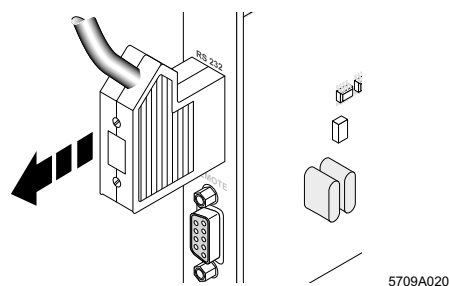

Figure 27 Unplugging the RS-232 cable

- Remove the controller board from the control system (see Figure 28).

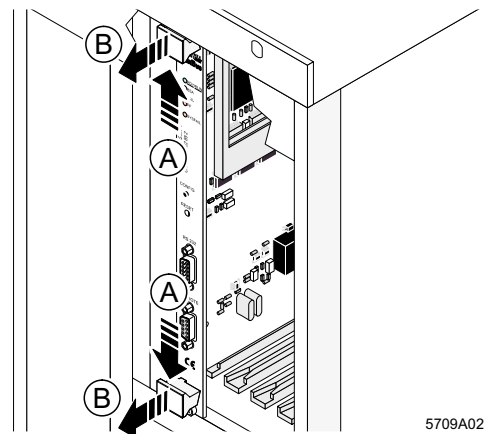



Figure 28 Removing the controller board

-  Unscrew the two slotted-head screws on the front plate of the controller board. Press the ejector (A) and uniformly pull the controller board out of the VMEbus rack (B).

- Take the controller board to be installed out of its packaging.
- Remove the memory card from the controller board to be replaced and insert it into the new board.
- Provide the new controller board with the base address of the controller board to be replaced and set the correct operating mode (see "Setting the DIP Switches" on page 14).

-  All switches are set to **OFF** by default.

- Install the controller board in the VMEbus rack. Make sure that the system connector is well-contacted and the controller board securely placed and locked in the control system (see also "Inserting the Controller Board Into the Control System" on page 22).

9. Plug in the remote bus cable and the RS-232 cable, if present, and secure the connection.

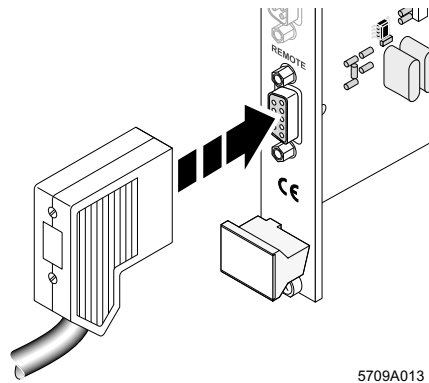

5709A013

Figure 29 Plugging in the remote bus cable

 Observe the operating instructions for your system before switching the control system on.

10. Switch on the power supply of the control system.

Replacing the Memory Card

 The IBS VME3H SC/I-T controller board has an internal (non plug-in) parameterization memory.

If it is necessary to replace the memory card of IBS VME6H... controller boards, please note the following:

1. Switch off the power supply of the control system.
2. Remove the controller board from the control system (see also "Replacing the Controller Board" on page 45).
3. Remove the memory card from the controller board.

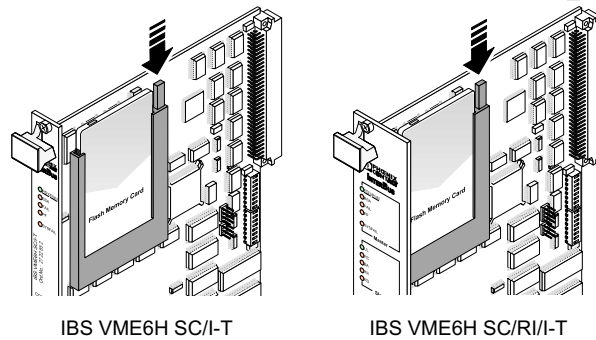

5709A022

Figure 30 Removing the memory card

 Press lightly on the ejector to raise the memory card, which can then be removed upwards.

 Before inserting the new memory card, you can write the name of the configuration file to be stored on the card in the labeling field using a water-resistant pen.

4. With the female connector going first, insert the memory card into the associated card holder. Make sure that when the memory card is pressed lightly the ejector moves outward and engages with a click (see Figure 31).

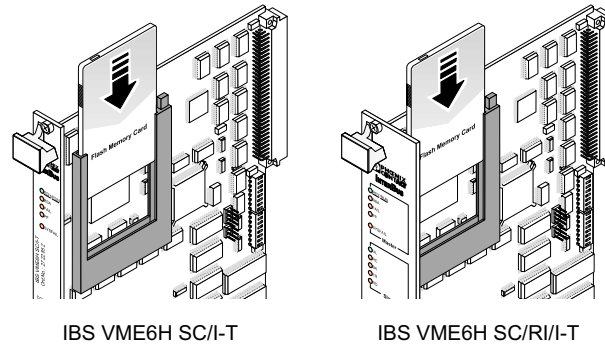

5709A005

Figure 31 Inserting the memory card

 As you insert the memory card, ensure that the card is located in the guide rails on both sides of the card holder. Make sure that the memory card is properly aligned!

 Only use the IBS MC FLASH memory card from Phoenix Contact (Order No. 27 51 77 1).

5. Re-install the controller board in the VMEbus rack.

Firmware Update of the Controller Board

The firmware (integrated software on the controller board) can be updated using the serial diagnostic and configuration interface RS-232" (for connection to a PC). Such firmware updates are used exclusively for the addition of new functions that are implemented within the scope of continuous product improvement. No update is required for normal system operation.

To update your controller board, please contact your nearest Phoenix Contact representative.

Connecting Cable

INTERBUS System Connection

Connect the remote bus cable to the remote bus interface of the controller board using a 9-pos. D-SUB female connector. An adapter for converting to fiber optics as the transmission medium can also be connected to this female connector.

Remote Bus Connector With Solder Connection

Designation IBS DSUB 9/L, Order No. 27 58 47 3

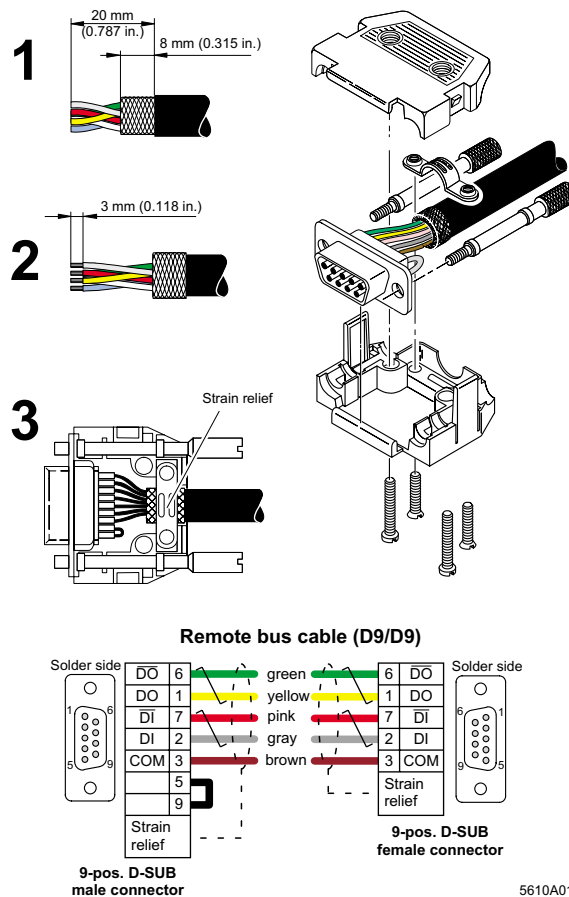



Figure 32 D-SUB connector cabling

1. Strip 20 mm (0.787 in.) off the cable sheath and shorten the braided shield to 8 mm (0.315 in.). Strip 3 mm (0.118 in.) off the wire ends and solder the signal lines according to the drawing.
2. Fold the braided shield back over the cable sheath.
3. Clamp the shield under the strain relief, so that a conductive connection to the metal-plated connector housing is created.

 Use only metal-plated connectors recommended by Phoenix Contact.

 In IBS VME6H SC/RI/I-T controller boards, the remote bus cable is also used to connect the slave interfaces (SL RB IN and SL RB OUT).

Remote Bus Connector With Screw-Clamp Connection

Designation SUBCON 9/M-SH, Order No. 27 61 50 9

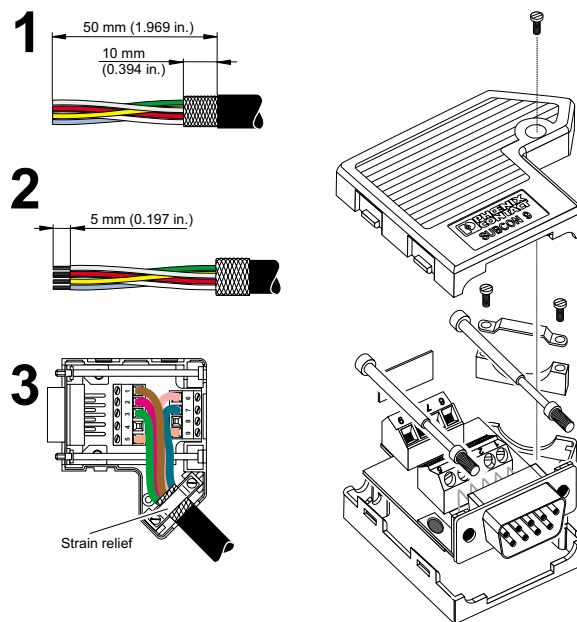

Remote bus cable (SUBCON 9/SUBCON 9)

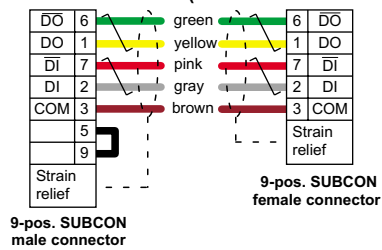

5610A019

Figure 33 SUBCON connector cabling

- Strip 50 mm (1.969 in.) off the cable sheath and shorten the braided shield to 10 mm (0.394 in.). Strip 5 mm (0.197 in.) off the wire ends and solder the signal lines according to the drawing.
- Fold the braided shield back over the cable sheath.
- Clamp the shield under the strain relief, so that a conductive connection to the metal-plated connector housing is created.

Fiber Optic Connector for Polymer Fibers

Designation IBS OPTOSUB-MA/M/R-LK

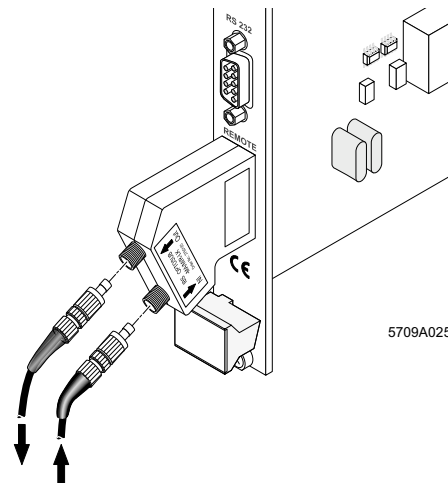



Figure 34 IBS OPTOSUB cabling

 It is also possible to order pre-assembled cables from Phoenix Contact (see Catalog Part 11 from Phoenix Contact). If these are not used, please refer to the package slips of the following items and the "Optical Fiber Installation Guidelines" for the assembly of fiber optic cables.

Ordering data:

IBS OPTOSUB-MA/M/R-LK Order No. 27 50 12 5
F-SMA/4 connector set with bending protection
(4 connectors)

PSM-SET-FSMA/4-KT Order No. 27 99 72 0
Polishing set

PSM-SET-FSMA-POLISH Order No. 27 99 34 8
Optical Fiber Installation Guidelines

DB GB IBS SYS FOC
ASSEMBLY Part No. 94 23 43 9

 The controller board supplies the OPTOSUB connector with power.

 Make sure that the power supply of the control system is switched off when plugging the OPTOSUB connector into the controller board.

Fiber Optic Connector for
a) Glass fiber (OPTOSUB-PLUS-G/OUT)
b) Polymer fiber (OPTOSUB-PLUS-K/OUT)

 Both interface converters can also be supplied as .../IN types.

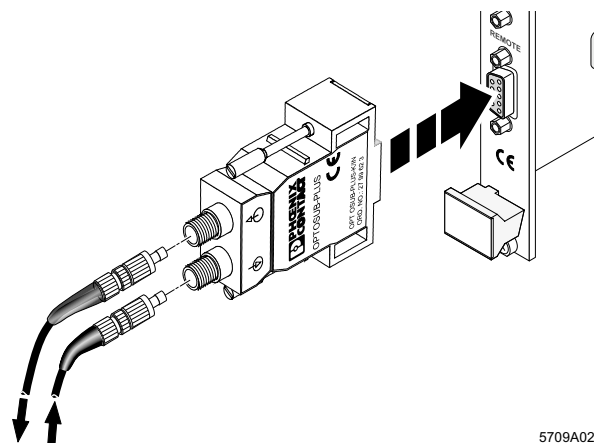

5709A024

Figure 35 OPTOSUB PLUS cabling



In the case of glass fiber cables, only pre-assembled cables should be used. (see Catalog Part 11 from Phoenix Contact).

Ordering data:

OPTOSUB-PLUS-G/OUT Order No. 27 99 63 6



The assembly of the polymer fiber cable is described in the package slips of the following items and the "Optical Fiber Installation Guidelines". It is also possible to order pre-assembled cables from Phoenix Contact (see Catalog Part 11).

Ordering data:

OPTOSUB-PLUS-K/OUT Order No. 27 99 61 0

F-SMA connector set with bending protection
(4 connectors)

PSM-SET-FSMA/4-KT Order No. 27 99 72 0

F-SMA polishing set

PSM-SET-FSMA-POLISH Order No. 27 99 34 8

Optical Fiber Installation Guidelines

DB GB IBS SYS FOC

ASSEMBLY Part No. 94 23 43 9

 The OPTOSUB PLUS connector does not require an additional power supply.

 Make sure that the power supply of the control system is switched off when plugging the OPTOSUB PLUS connector into the controller board.

onlinecomponents.com

Fiber Optic Connector for Glass Fibers

Designation PSM-EG-RS422/LWL-G

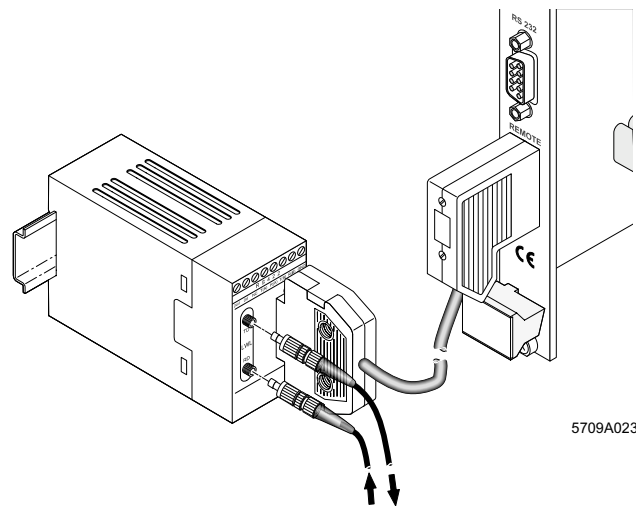

Figure 36 Cable connection with interface converter



In the case of glass fiber cables, only pre-assembled cables should be used (see Catalog Part 11 from Phoenix Contact).

Ordering data:

1) Interface converter

PSM-EG-RS422/LWL-G Order No. 27 61 33 4

2) Pre-assembled remote bus cable

IBS DSUB 9/15-KONFEK/SO Order No. 27 53 35 5

Notes:

onlinecomponents.com

onlinecomponents.com



We Are Interested in Your Opinion!

We would like to hear your comments and suggestions concerning this document.

We review and consider all comments for inclusion in future documentation.

Please fill out the form on the following page and fax it to us or send your comments, suggestions for improvement, etc. to the following address:

Phoenix Contact GmbH & Co.
Marketing Services
INTERBUS Documentation
32823 Blomberg
GERMANY

Phone +49 - 52 35 - 3 00
Fax +49 - 52 35 - 34 20 66
E-mail tecdoc@phoenixcontact.com

FAX Reply



**Phoenix Contact GmbH & Co.
 Marketing Services**

Date:

INTERBUS Documentation Fax: + 49 - (0) 52 35 - 34 20 66

From:

Company: Name:
 Departm.:
 Address: Function:
 City: Phone:
 ZIP-Code: Fax:
 Country:

Document:

Designation:.....
 Revision: Order No.:.....

My Opinion of the Document

Form	Yes	In part	No
Is the table of contents clearly arranged?	<input type="checkbox"/>	<input type="checkbox"/>	<input type="checkbox"/>
Are the figures/diagrams easy to understand/helpful?	<input type="checkbox"/>	<input type="checkbox"/>	<input type="checkbox"/>
Are the written explanations of the figures adequate?	<input type="checkbox"/>	<input type="checkbox"/>	<input type="checkbox"/>
Does the quality of the figures meet your expectations/needs?	<input type="checkbox"/>	<input type="checkbox"/>	<input type="checkbox"/>
Does the layout of the document allow you to find information easily?	<input type="checkbox"/>	<input type="checkbox"/>	<input type="checkbox"/>

Contents	Yes	In part	No
Is the phraseology/terminology easy to understand?	<input type="checkbox"/>	<input type="checkbox"/>	<input type="checkbox"/>
Are the index entries easy to understand/helpful?	<input type="checkbox"/>	<input type="checkbox"/>	<input type="checkbox"/>
Is any important information missing? If yes, what?	<input type="checkbox"/>	<input type="checkbox"/>	<input type="checkbox"/>
Are the examples practice-oriented?	<input type="checkbox"/>	<input type="checkbox"/>	<input type="checkbox"/>
Is the document easy to handle?	<input type="checkbox"/>	<input type="checkbox"/>	<input type="checkbox"/>

If you have other comments, please write and fax to the number indicated above.

onlinecomponents.com

5709B



Onlinecomponents.com

Phoenix Contact GmbH & Co
Flachmarktstr. 8
32825 Blomberg
Germany

 + 49 - 52 35 - 3 00

 + 49 - 52 35 - 34 12 00

 www.phoenixcontact.com