

746 ER



FAAC

for sliding gates with max weight of 600 kg

746 ER Z16 for rack applications

746 ER Z20 for rack applications (400 Kg)

746 ER CAT for chain applications

746 ER RF for chain applications with idle transmission



■ Ideal for residential applications

The control board inside the gearmotor facilitates and speeds up installation, at lower cost. Its compact size makes it ideal for residential applications with gates weighing up to 600 kg.

■ Totally safe, reliable in all conditions

Safety is guaranteed by the special, adjustable, oil-bath lubricated anti crushing clutch, and by an intelligent electronic device which, when it detects the presence of an obstacle, reverses and stops gate movement. The FAAC 746 gearmotor performs uniformly, and all commands are supplied by an extremely safe and reliable microprocessor.

■ Long life

Constant, complete oil-bath lubrication of mechanical components plus assembly in a high resistance pressure-cast aluminium body ensure a very long life.

■ Irreversible

As the gearmotor is non reversing, no electric locks need be installed and, in the event of power failure, the release device (protected by a customized key) makes it possible to open and close the gate manually.

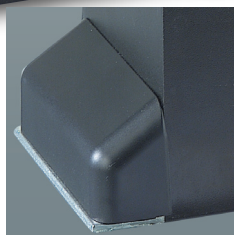

www.DigiDsc.com
09123036082
02144929013

■ Cover

■ Release device with customised key

■ Screw cover

■ Base in pressure-cast aluminium with cathodolysis treatment

SPECIFICATIONS

Non-reversing screw gearmotor • Gate max. weight 600 kg • Gate speed 12 m/min (Z20) and 9.6 m/min (Z16) • Max. use frequency 70% • Max thrust 50 daN • Electric motor power supply 230 Vac (+6% - 10%) - 50 (60) Hz • Electric motor power 300 W • Thermal protection at 120 °C built into motor winding • Operating ambient temperature - 20°C ÷ + 55°C • Protection class IP 44 • Lever operated release device with code key • Single - phase motor with two rotation directions (1.400 rpm) • Pinion gear Z20/module 4 • Inductive limit - switch (chain version) • Magnetic limit-switch (rack version) • Lower and upper half-body in die - cast aluminium with cathodolysis treatment • Twin-disk clutch in oil-bath • Opening/closing force adjustable by hexagonal key • Galvanised foundation plate with side and height adjustment (optional) • Dimensions 275x191x336 mm (LxWxH) • Built-in control board • ABS control board enclosure

780D control board

Transformer: faston connection to the PCB • Power supply: 230 Vac (+6%-10%) 50 Hz • Absorbed power: 10 W • Motor max. load: 1000 W • Accessories max. load: 0,5 A • Operating ambient temperature: -20°C ÷ +55°C • Fuses: 2 • Function logics: Automatic/"Stepped" automatic/Semi-automatic/Safety devices/Semi-automatic B / Dead-man C /"Stepped" semi-automatic / Mixed B/C logic • Work time: Programmable (from 0 to 4,1 min) • Pause time: Programmable (from 0 to 4,1 min) • Thrust force: Adjustable over 50 levels • Terminal board inputs: Open - Partially Open - Opening safety devices - Closing safety devices - Stop - Edge - Power supply + Earth • On-connector inputs: Opening and closing limit-switch/Motor capacitor • Terminal board outputs: Flashing lamp - Motor - 24 Vdc accessories power supply - 24Vdc indicator-light - Timed output - Electric lock command - "traffic lights" - Fail safe • Rapid connector: Plug-in receiver - Decoding card • Programming: Nr. 3 keys(+,-,F) and display, "basic" or "advanced" mode • "Basic" mode programmable functions: Function logic - Pause time - Thrust force - Opening-closing direction • "Advanced" mode programmable functions: Torque at initial thrust - Braking - Fail safe - Pre-flashing - Indicator-light/Timed output/Electric lock or "traffic lights" command - Opening and closing safety devices logic - Encoder/Anti-crushing sensitivity - Deceleration - Partial opening time - Worktime - Assistance request - Cycle counter

746 ER

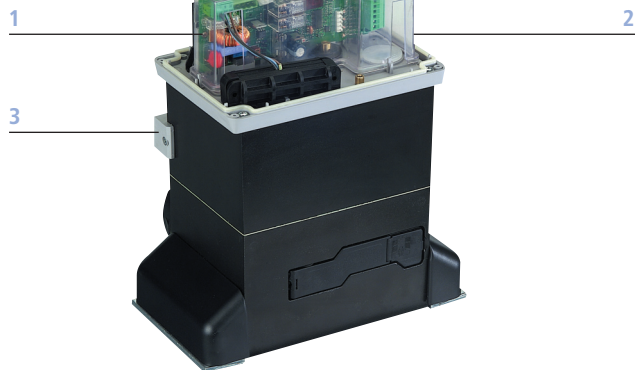

- 1 780D control board
- 2 Protection cover
- 3 Inductive limit-switch (chain version)

marka.bo.it

Specifications of 780 D control board (to be assembled inside the gearmotor)

Power supply	230 Vac (+6%-10%) 50 Hz
Absorbed power	10 W
Motor max. load	1000 W
Accessories max. load	0,5 A
Operating ambient temperature	-20°C ÷ +55°C
Fuses	2
Function logics	Automatic/"Stepped" automatic/Semi-automatic/Safety devices/Semi-automatic B/Dead-man C/"Stepped" semi-automatic/Mixed B/C logic
Work time	Programmable (from 0 to 4,1 min)
Pause time	Programmable (from 0 to 4,1 min)
Thrust force	Adjustable over 50 levels
Terminal board inputs	Open - Partially Open - Opening safety devices - Closing safety devices - Stop - Edge - Power supply+earth
On-connector inputs	Opening and closing limit-switch/Motor capacitor
Terminal board outputs	Flashing lamp - Motor - 24Vdc accessories power supply - 24Vdc indicator-light - Timed output - Electric lock command - "Traffic lights" - Fail safe
Rapid connector	5-pin card connection for Minidec - Decoder or RP receivers
Programming	Nr. 3 keys(+, -, F) and display, "basic" or "advanced" mode
"Basic" mode programmable functions	Function logic - Pause time - Thrust force - Opening-closing direction
"Advanced" mode programmable functions	Torque at initial thrust - Braking - Fail safe - Pre-flashing - Indicator-light/Timed output/Electric lock or "traffic lights" command - Opening and closing safety devices logic - Encoder/Anti-crushing sensitivity - Deceleration - Partial opening time - Worktime - Assistance request - Cycle counter
Status indication	Display

INSTALLATION LAYOUT

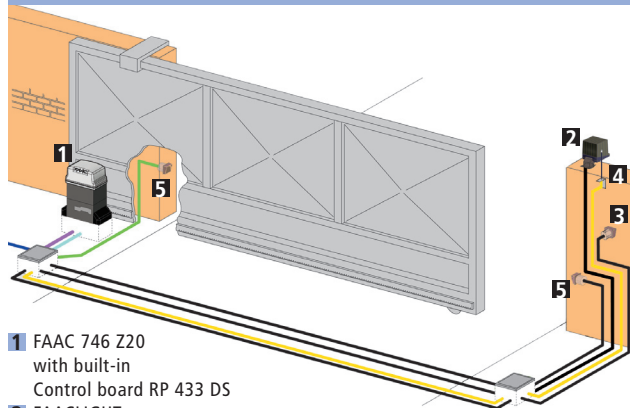

- 1 FAAC 746 Z20 with built-in Control board RP 433 DS
- 2 FAACLIGHT
- 3 FAAC T10 E
- 4 ANTENNA 433 Mhz
- 5 FAAC SAFEBEAM

	Low voltage cabling	Power cabling (230V)
(A)	3 cables 3x0,5 1 cable 2x0,5	(B) 1 cable 2x1,5+T 1 cable 2x1,5

N.B: Cable diameters in mm²

Technical specifications 746 ER	Z16	Z20	CAT	RF
Power supply	230 Vac (+ 6%-10%) 50 (60) Hz			
Electric motor	Single-phase, bi-directional			
Absorbed power	300 W			
Absorbed current	1.5 A			
Traction and thrust force	0÷62 daN	0÷50 daN		
Motor rotation speed	1.400 rpm			
Thermal protection on motor winding	120 °C			
Clutch	Twin-disk in oil bath			
Reduction ratio	1:30			
Operating ambient temperature	-20 °C ÷ + 55°C			
Weight with oil	14 Kg			
Type of oil	FAAC OIL XD 220			
Gate speed	9.6 m/min.	12 m/min.		
Protection class	IP 44			

Model	Use		Control board
	Max weight (kg)	Use frequency (cycles/hour)	
746 ER Z16	600	70	780 D included
746 ER Z20	400	70	780 D included
746 ER CAT (*)	-	70	780 D included
746 ER RF (*)	-	70	780 D included

*WARNING: Do not use the operator for applications that require it to be fixed at heights where it cannot be reached by users. The keyrelease device cannot be remote controlled. For "overhead" applications we recommend the use of 820/860 automations.

www.DigiDsc.com
09123036082
02144929013



FAAC S.p.A. Via Benini, 1
40069 Zola Predosa - Bologna (Italy)
tel. +39 051 61724 · fax +39 051 758518
www.faacgroup.com



DIMENSIONS

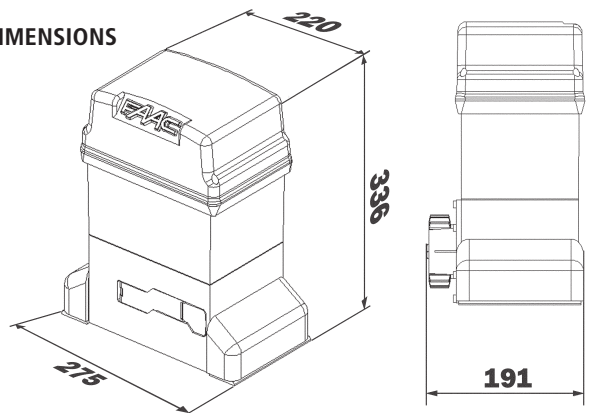

Values in mm

908278004 - Rev. 10 - Zucchini - 3.000 - 09/2006 - The descriptions and illustrations contained in the present brochure are not binding. FAAC reserve the right to undertake product technical modifications without prior notice.