

Z7A

Load cells

Special features

- Complies with OIML R60 regulations up to 3000 d
- Max. capacities: 500 kg ... 10 t
- Fulfills EMC requirements in accordance to EN 45 501
- Low transducer height
- Robust design
- Explosion protection designs as per ATEX and IECEx



Cable assignment (6-wire configuration)

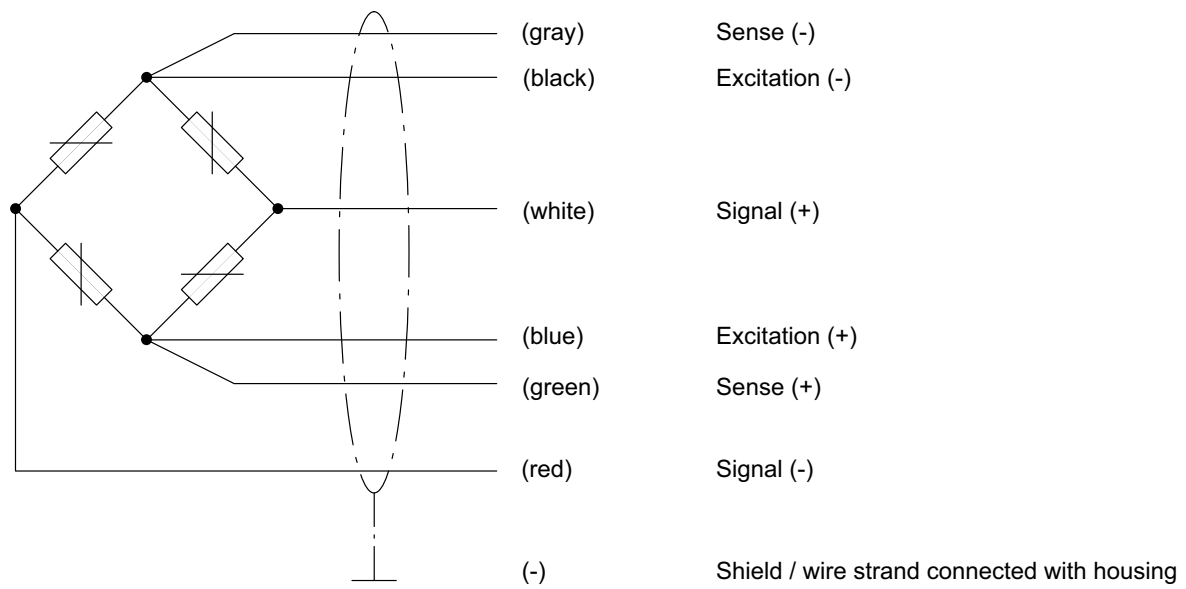

Specifications

Type			Z7A							
Accuracy class according to OIML R 60			D1				C3			
Max. number of load cell verification intervals	n_{LC}		1000				3000			
Max. capacity	E_{max}	t	0.5	1	2	5	10	2	5	10
Min. load cell verification interval	v_{min}	% of E_{max}	0.0357				0.0100			
Ratio of minimum verification interval	Y		2800				10000			
General specifications										
Sensitivity	C_n	mV/V	2							
Sensitivity tolerance		%	±0.1000				±0.0500			
Temperature effect on sensitivity ¹⁾	TK_C	% of C_n / 10 K	±0.0350				±0.0117			
Temperature effect on zero signal	TK_0		±0.0500				±0.0140			
Hysteresis error ¹⁾	d_{hy}	% of C_n	±0.0500				±0.0170			
Non-linearity ¹⁾	d_{lin}		±0.1000				±0.0333			
Creep in 30 min.	d_{cr}		±0.0735				±0.0167			
Input resistance at reference temperature	R_{LC}	Ω	> 350							
Output resistance at reference temperature	R_O		356±0.2				356±0.12			
Nominal rang of excitation voltage	U_{ref}	V	0.5...12							
Maximum excitation voltage	B_U		18							
Reference temperature		°C [°F]	+23 [+73.4]							
Nominal temperature range	B_T		-10...+40 [+14...+104]							
Operating temperature range	B_{tu}		-30...+70 [-22...+158]							
Storage temperature range	B_{tl}		-50...+85 [-58...+185]							
Save load limit	E_L	% of E_{max}	150							
Breaking load	E_d		300							

Max. capacity	E_{max}	t	0.5	1	2	5	10
Relative static lateral force limit ²⁾	E_{lq}	% of E_{max}	100	50	25 (100) ²⁾	15 (100) ²⁾	18 (100) ²⁾
Permissible dynamic load (vibration amplitude according to DIN 50100)	F_{srel}		70				
Nominal displacement, approx.	s_{nom}	mm	0.25	0.30	0.35	0.45	0.70
Weight, approx.	G	kg	2.3	2.3	2.3	5	8
Degree of protection according to EN60529 (IEC529)			IP 67				
Material Measuring body Cable gland Cable sheath			Steel, galvanized Stainless steel / Viton® PVC				

¹⁾ The values stated for the non-linearity, the hysteresis and the temperature coefficient of sensitivity are standard values. The sum of these values is within the accumulated error limit according to OIML R60.

²⁾ The values given in parentheses refer to installation with stops preventing the transducer base from moving. In this case, major error effects have to be anticipated.

Options

Explosion protection versions as per IECEx and ATEX

AI1/21 IECEx+ATEX zone 1/21 intrinsically safe, II 2G Ex ia IIC T6/T4 Gb, II 2D Ex ia IIIC T125°C Db*

AI2/22 IECEx+ATEX zone 2/22 non-intrinsically safe, II 3G Ex ec IIC T6/T4 Gc, II 3D Ex tc IIIC T125°C Dc*

* With EU type examination certificate (BVS13ATEX E 108 X) and IECEx Certificate of Conformity (IECEx BVS 13.0109 X)

Dimensions Z7A (in mm, 1mm = 0.03937inches)

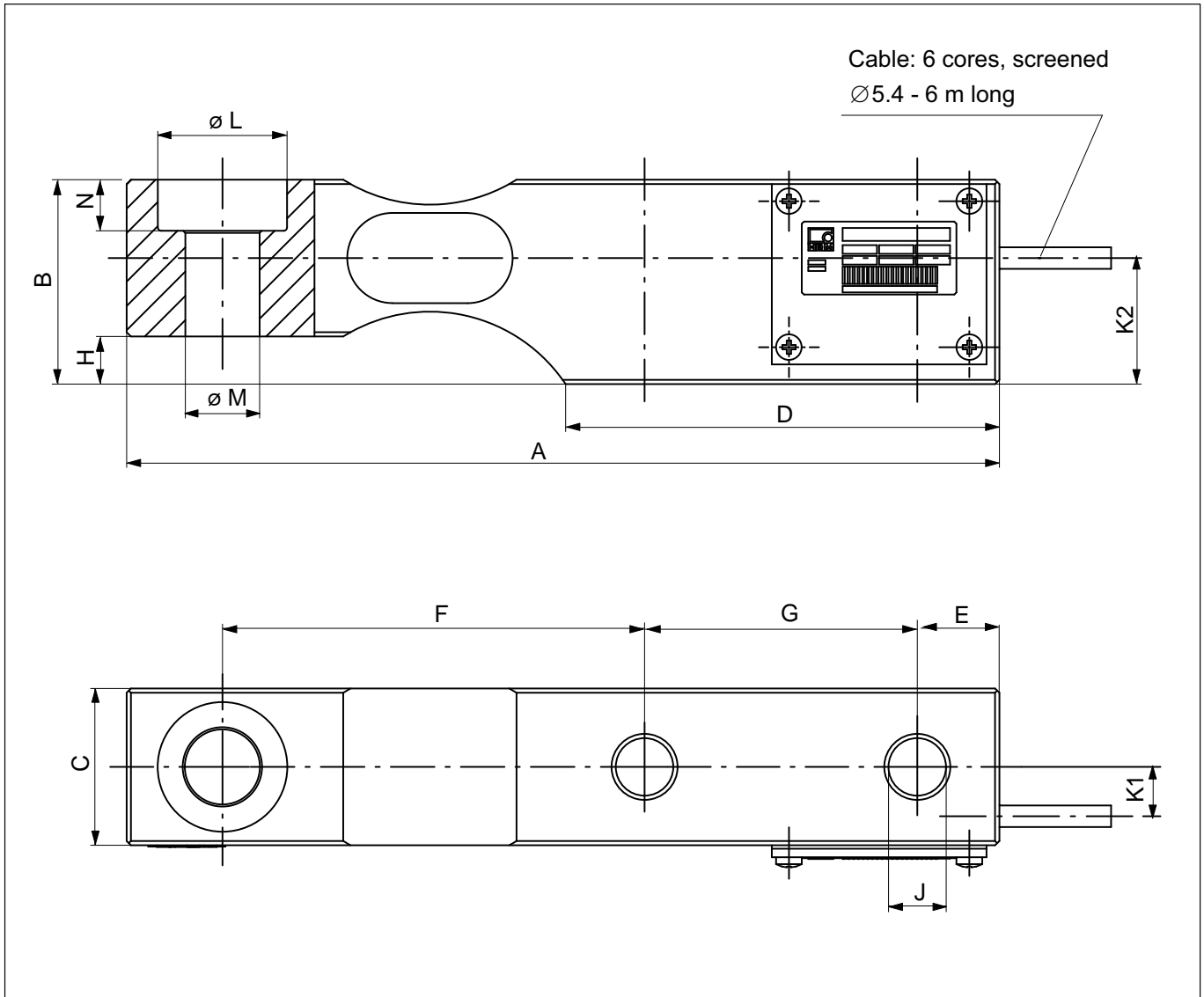

Nominal load in t	L ^{+0.2}	M ^{H11}	J	B	H	N	A	D	F	G	E	C	K1	K2	M* in N·m
0.5 and 1	30.2	17.5	13.4	47.6	11.1	11.9	203.2	101	98.3	63.5	19.1	36.5	10.6	29	135
2	30.2	17.5	13.4	47.6	11.1	11.9	203.2	102	98.3	63.5	19.1	36.5	10.6	29	135
5	41.3	25.5	22.5	70	22.2	15.9	235	118	123.7	66.5	20.6	47.6	16	46	660
10	51	32	27	82.6	19.1	20.7	279.4	140	139.7	82.6	25.4	60.3	21	51	1150

* Tightening torque with screws of property class 10.9 (with $\mu=0.16$).

Accessories, to be ordered separately:

- Rubber-metal bearing ZEL
- Pendulum bearing ZPL

Mounting aids (Dimensions in mm; 1mm = 0.03937 inches)

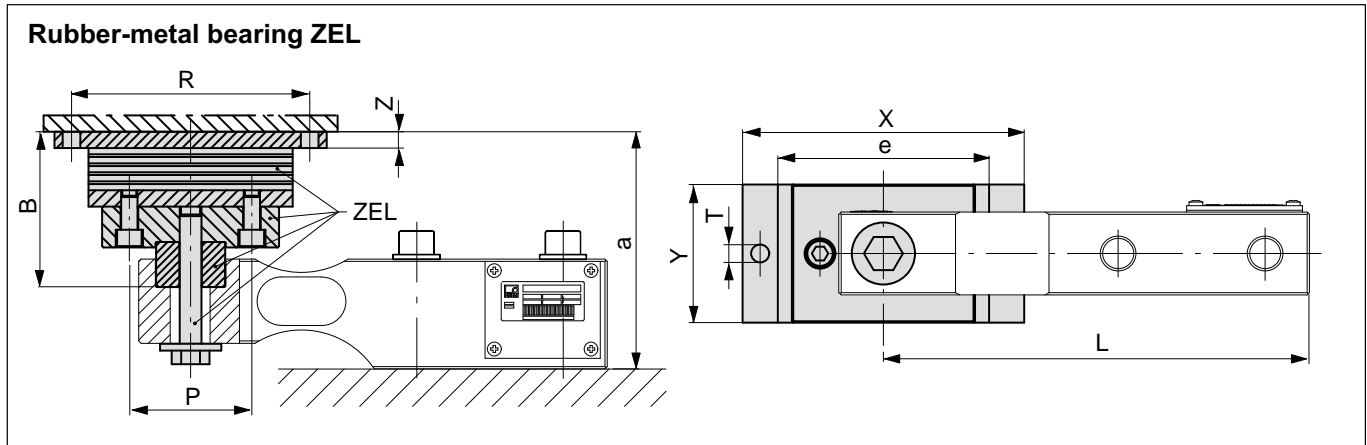

Max. capacity in t	Rubber-metal bearing ZEL	B	L	P	R	T	X	Y	Z	a	e	F _R * (N)	s _{max} ** (mm)
0.5...2	Z17/2t/ZEL	76.3	180.9	70	100	9	120	60	10	112 ^{+1,5} _{-1,7}	80	400	4.5
5	Z17/5t/ZEL	93	210.8	70	125	11	150	100	10	147 ^{+1,2} _{-2,0}	100	620	8
10	HLCB/10t/ZEL	114.1	247.7	90	175	13	200	100	12	176 ^{+1,8} _{-2,0}	130	810	9.5

* F_R =restoring force for s=1mm.

** s_{max} =max. lateral displacement of load introduction with max. capacity.

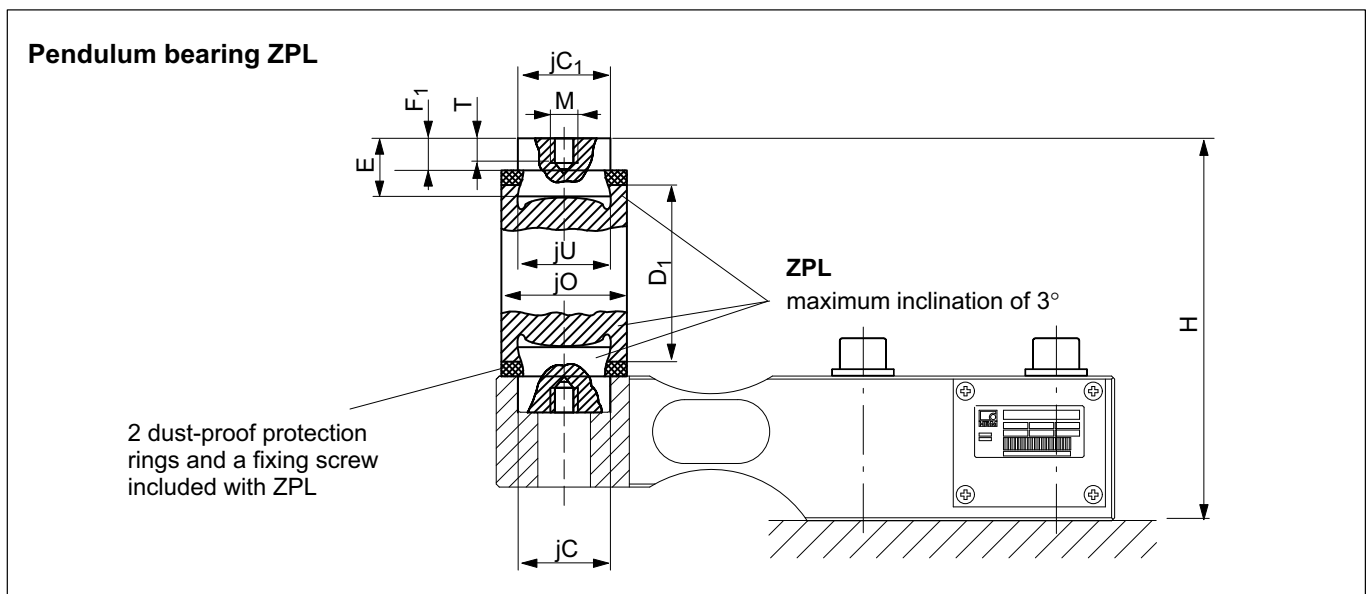

Max. capacity in t	Pendulum bearing ZPL	C ^{+0.2}	C ₁ ^{-0.1}	D ₁	E	F ₁	H	M	O	T	U ^{D10} _{h9}	F _R * (% of load)	s _{max} ** (mm)
0.5...2	Z17/2t/ZPL	30.2	30	60	22	14	130±0.5	M10	46	8	30	2	7.5
5	Z17/5t/ZPL	41.3	41.1	73	26	16	169±0.5	M10	48	8	30	1.5	6.9
10	Z17/10t/ZPL	51	50.8	82	32	21	196±0.5	M12	58	10	40	1.8	9.3

* F_R =restoring force for s=1mm.

** s_{max} =max. lateral displacement of load introduction with nominal load.

Placing orders

When placing an order please specify the ordering numbers from the tables. If you need other versions (accuracy classes, explosion protection, other cable lengths, etc.) for the available products, please look in the overview "Z7A load cells, optional versions". You can generate a specific ordering number there from your individual requirements.

Maximum capacity	Accuracy class	
	D1	C3
500 kg	1-Z7AD1/500KG	
1 t	1-Z7AD1/1T	
2 t	1-Z7AD1/2T	1-Z7AC3/2T
5 t	1-Z7AD1/5T	1-Z7AC3/5T
10 t	1-Z7AD1/10T	1-Z7AC3/10T

Cable lengths: All maximum capacities have a 6 m cable as standard

Z7A load cells, optional versions

Order number	
K-Z7A	
Code	Option 1: Mechanical design
S	Standard
Code	Option 2: Accuracy class
D1	D1 (OIML)
C3	C3 (OIML) [only with Option 3 = 2 / 5 / 10]
Code	Option 3: Max. capacity
500	500 kg [only with Option 2 = D1]
1	1 t [only with Option 2 = D1]
2	2 t
5	5 t
10	10 t
Code	Option 4: Explosion protection
N	No explosion protection
AI1/21	IECEX + ATEX zone 1/21
AI2/22	IECEX + ATEX zone 2/22
Code	Option 5: Cable length
S	6 m (standard)
12	12 m
Code	Option 6: Other
N	Standard

K-Z/A - S - [] - [] - [] - [] - [] - [] - N

Not all codes can be combined with one another. Take note of the conditions in square brackets!

Subject to modifications.
All product descriptions are for general information
only. They are not to be understood as a guarantee
of quality or durability.

Hottinger Baldwin Messtechnik GmbH
Im Tiefen See 45 · 64293 Darmstadt · Germany
Tel. +49 6151 803-0 · Fax +49 6151 803-9100
Email: info@hbm.com · www.hbm.com

measure and predict with confidence

