



Flame detector

QRA4...

UV flame detector for use with burner controls from Siemens for the supervision of gas or oil flames.

The QRA4... and this Data Sheet are intended for use by OEMs which integrate the flame detectors in their products.

Use

The flame detector is used for the supervision of gas flames, yellow- or blue-burning oil flames and for ignition spark proving in intermittent operation.

The QRA4... is for use with the following types of burner control:

QRA4.U	QRA4M.U	Burner control	Data Sheet
•	---	LFL...	N7451
•	---	LFE1...	N7461
•	---	LFE10...	N7781
•	•	LFS1	N7782
•	---	LGB2... / LGB4... with AGQ1...	N7435
•	---	LME21...C2 / LME22...C2 with AGQ3...	N7101
•	---	LME39...C2 with AGQ3...	N7106
•	---	LME41...C2 / LME44...C2 with AGQ3...	N7101
•	---	LME7...	N7105
•	•	LMV26.300... with AGM60.1...	N7547
•	•	LMV27.100...	N7541
•	•	LMV36.520... with AGM60.4...	N7544
•	•	LMV37.4...	N7546
•	---	LMV5... with AGQ1...	N7550

Other burner controls on request.

Warning notes



To avoid injury to persons, damage to property or the environment, the following warning notes must be observed!

Do not open, interfere with or modify the flame detector! Siemens will not assume responsibility for damage resulting from unauthorized interference!

- All activities (mounting, installation and service work, etc.) must be performed by qualified personnel
- Before making any wiring changes in the connection area, completely isolate the plant from mains supply (all-polar disconnection). Ensure that the plant cannot be inadvertently switched on again and that it is indeed dead. If not observed, there is a risk of electric shock hazard.
- Ensure protection against electric shock hazard by providing adequate protection for the connection terminals. If this is not observed, there is a risk of electric shock
- Each time work has been carried out (mounting, installation, service work, etc.), check to ensure that wiring is in an orderly state. If this is not observed, there is a risk of loss of safety functions and a risk of electric shock
- Halogen lamps, welding equipment, special lamps or ignition sparks may produce sufficient radiation for the detector's UV cell to ignite. X-rays and gamma radiation can also generate erroneous flame signals. If this is not observed, there is a risk of loss of safety functions
- Fall or shock can adversely affect the safety functions. Such detectors must not be put into operation, even if they do not exhibit any damage. If this is not observed, there is a risk of loss of safety functions and a risk of electric shock

Mounting notes

- Ensure that the relevant national safety regulations are complied with

Installation notes

- Always run the high-voltage ignition cables separate while observing the greatest possible distance to the detector and to other cables

Electrical connection of the flame detector

It is important to achieve practically disturbance- and loss-free signal transmission:

- Never run the detector cable together with other cables
 - Line capacitance reduces the magnitude of the flame signal
 - Use a separate cable
- Observe the permissible lengths of the detector cable (refer to «Technical data» of burner control / basic documentation used)
- The connecting wires must be run through protective tubing (made of plastic or earthed metal)

Commissioning notes

Trouble-free burner operation is ensured only when the intensity of UV radiation at the detector's location is high enough for the detector's UV cell to ignite during each half wave. The **intensity of UV radiation** at the detector's location is **checked by measuring the detector current** (refer to Data Sheet of the respective burner control)

Measuring circuit
for QRA4...

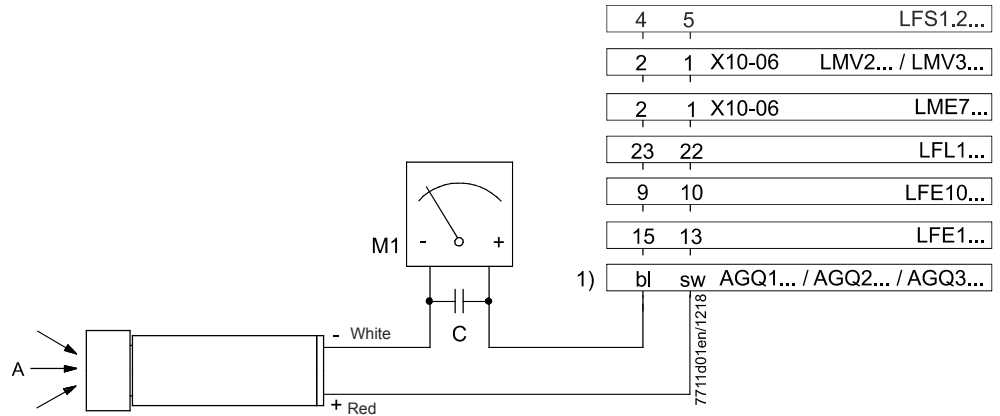

Legend

- 1) Connection of microammeter across adapter AGQ1... / AGQ2... / AGQ3... and flame detector
- A Incidence of radiation
- M Microammeter (DC), internal resistance $\leq 5,000 \Omega$
- C Electrolytic capacitor 100...470 μF , DC 10...25 V

Standards and certificates



Note!
Only in connection with burner controls!



EAC Conformity mark (Eurasian Conformity mark)



ISO 9001:2015
ISO 14001:2015
OHSAS 18001:2007



China RoHS
Hazardous substances table:
<http://www.siemens.com/download?A6V10883536>



Service notes

The UV cell is glued inside the housing and cannot be removed. When the end of the UV cell's service life is reached, the complete flame detector must be replaced.

Disposal notes

The flame detector contains electrical and electronic components and must not be disposed of together with domestic waste.
Local and currently valid legislation must be observed.

Mechanical design





Flame detector QRA4... UV flame detector for frontal illumination. Housing made of aluminum, with $\frac{3}{4}$ "-14NPSM connecting thread for fitting the detector to the burner or boiler. Connecting wires of about 1.8 m length for the electrical connection. $\frac{1}{2}$ "-14NPSM thread for a fitting, required for the connection of a Menzel tube for protecting the connecting wires ($\frac{1}{2}$ " conduit).

Ordering

Article no.	Type	Sensitivity
BPZ:QRA4.U	QRA4.U	Normal
BPZ:QRA4M.U	QRA4M.U	High

When ordering, please give the complete type reference according.

Accessories

Article no.	Type	Designation
BPZ:AGG02	AGG02	Heat insulation glass with spring washer and O-ring See Mounting instruction 4 319 9511 0 (M7712)
BPZ:AGG04	AGG04	Mounting coupling Adapter of QRA4...-NPSM thread for a European pipe thread (G1"). 
BPZ:AGG15	AGG15	Heat insulating piece between QRA4... and mounting coupling AGG04.   AGG04  AGG15

Technical data

General detector data	Average life of UV cell	Approx. 10,000 hours at max. +50 °C, higher ambient temperatures reduce considerably the cell's life	
	Perm. combustion chamber pressure	Max. 150 mbar	
	Degree of protection	IP54 (to be ensured through mounting)	
	Mounting position	Optional	
	Weight	Approx. 180 g	
	Device safety class	II (double-insulated) 	
	Length of connecting wires		
	- QRA4...	Approx. 180 g	
	- AGG02	Approx. 10 g	
	- AGG04	Approx. 270 g	
	- AGG15	Approx. 100 g	
	Conduit for protective sleeve (Menzel sleeve)	1/2"-14NPSM thread	
	Environmental conditions	Storage	IEC 60721-3-1
		Climatic conditions	Class 1K3
Mechanical conditions		Class 1M2	
Temperature range		-20...60 °C	
Humidity		<95% r.h.	
Transport		IEC 60721-3-2	
Climatic conditions		Class 2K3	
Mechanical conditions		Class 2M2	
Temperature range		-20...60 °C	
Humidity		<95% r.h.	
Operation		IEC 60721-3-3	
Climatic conditions		Class 3K5	
Mechanical conditions		Class 3M5	
Temperature range		-20...60 °C	
Humidity	<95% r.h.		
Installation altitude	Max. 2,000 m above sea level		



Caution!

Condensation, formation of ice and ingress of water are not permitted!

If this is not observed, there is a risk of loss of safety functions and a risk of electric shock.

Function

With this type of flame supervision, the UV radiation emitted by gas or oil flames is used to generate the flame signal.

The radiation detector is a UV-sensitive cell with 2 electrodes, which ignite when illuminated with radiation in the 190...270 nm range of the spectrum, thereby triggering a current in the flame detector circuit.

The UV cell does not respond to glowing firebrick in the combustion chamber or to daylight.

Dimensions

Dimensions in mm

Flame detector QRA4...

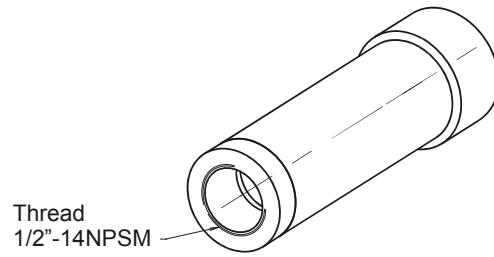
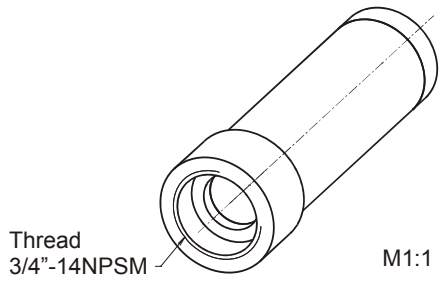
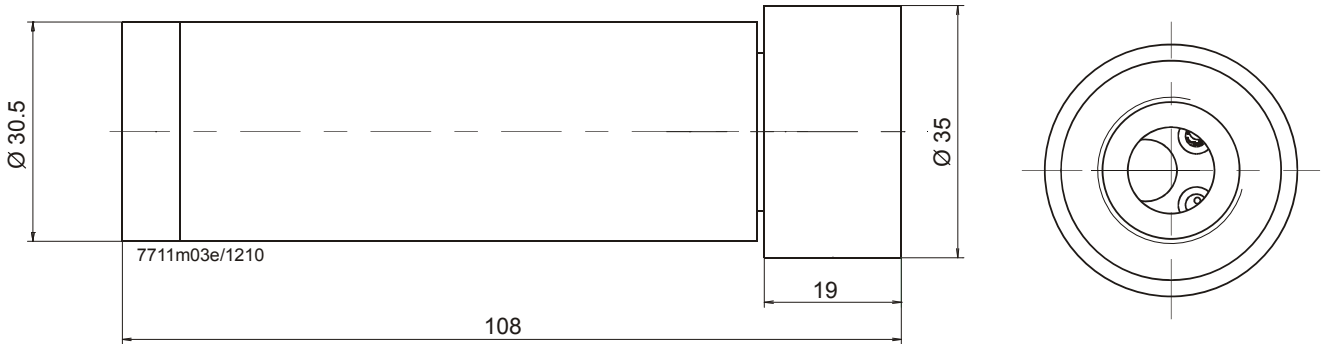

Heat insulation glass
AGG02

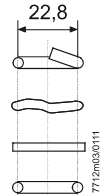

Mounting coupling
AGG04

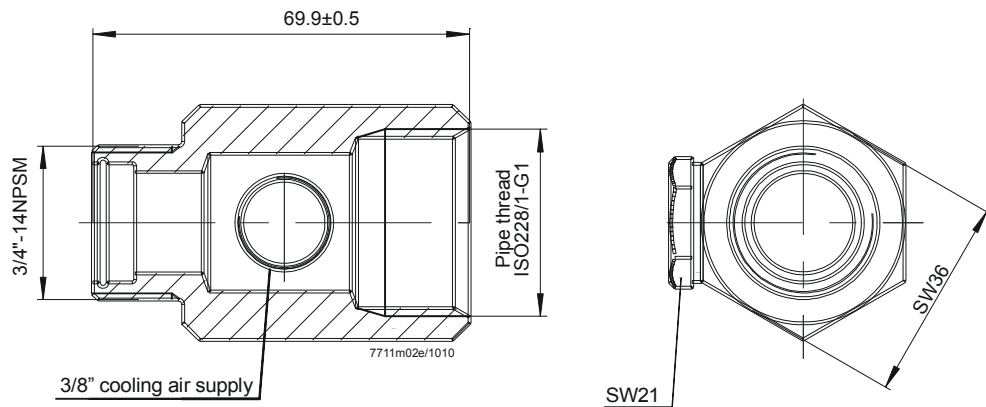

©2018 Siemens AG Building Technologies, Berliner Ring 23, D-76437 Rastatt
Subject to change!