

## ZXT-B Automatic Tension Controller

### User Manual

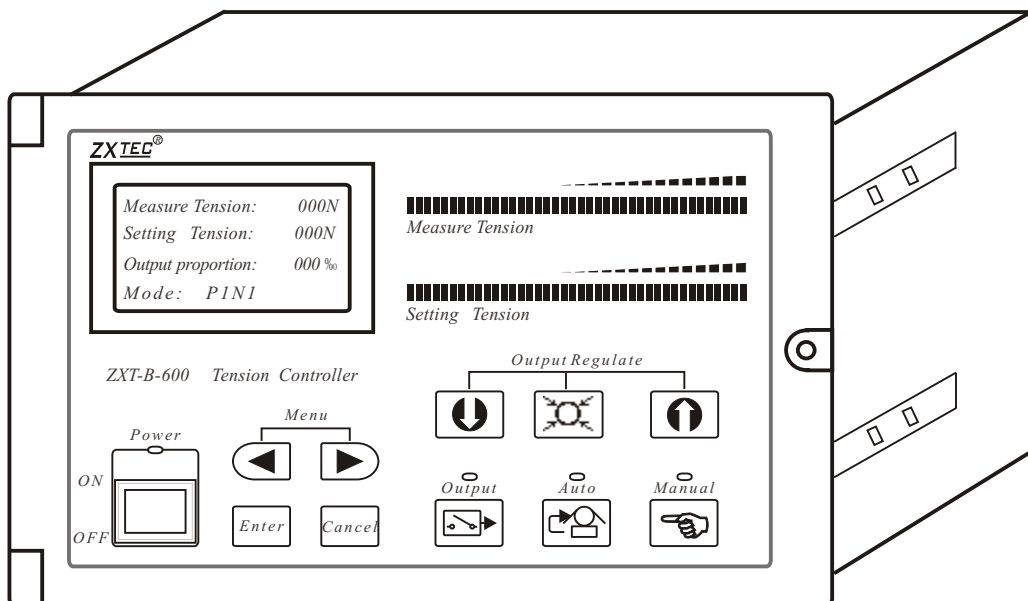
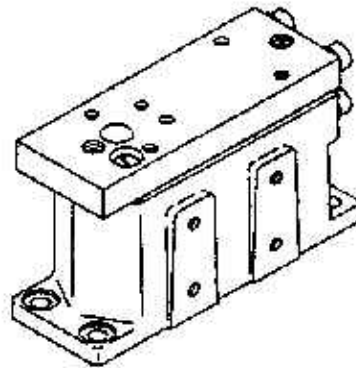
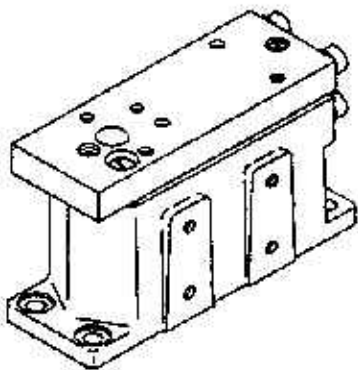

ZhongXing Industry Control Device Co.,Ltd. Rui'an City

[Http://www.zxtec.cn](http://www.zxtec.cn)

## Catalogue

<i>One. Fast operation and usage</i>	<i>P1</i>
<i>Two. Elucidation of model number</i>	<i>P2</i>
<i>Three. Size of controller and tension detector</i>	<i>P3</i>
<i>Four. Installing of tension detector</i>	<i>P4</i>
<i>Five. Name and function of each parts of controller</i>	<i>P5</i>
<i>Six. Work principle of tension controller</i>	<i>P7</i>
<i>Seven. Wiring Diagram</i>	<i>P9</i>
<i>Eight. Function of Hall switch</i>	<i>P10</i>
<i>Nine. Reason and function of limit output</i>	<i>P10</i>
<i>Ten. Convert switch of duplex bit</i>	<i>P11</i>
<i>Eleven. Analogue output</i>	<i>P11</i>
<i>Twelve. Setting parameter</i>	<i>P12</i>



*Avowal: We have reserved some electric circuit data concerned because we use some more forerunner's A/D,D/A integrated circuit, invite an understanding to the utmost.*

## *One. Fast operation and usage*

*1. Install tension detector: Customer can install a tension detector by level, perpendicularity or side on the basis of own demand.*

*Notice: Tension detector disallows hard gearing with the article and should use universal pedestal to install transition as far as possible. Screw installed shouldn't longer than the fixed plank of the tension detector; The perpendicular gearing tension detector should notice the fulcrum of it with an upward exposure namely fuse with an upward exposure. On the sides installing the setting bolt that the tension detector should notice is not too long, otherwise it will cause the detector permanence damage.*

*2. Install tension detector: According to the item of wiring diagram and connect the input, output and power lead of the controller correspond.*

*Notice: The power lead of the tension controller should try to be far away from the source of the disturbance such as the button, AC electromagnetic contactor and so on.*

*3. Start the machine and check the tension detector: Turn on the power of the controller after finishing installation. Press the menu into number six to check whether the tension detector install correctly or not. If correctly, the value of the two tension detectors should between 1000-2000, and this time you press the tension detector by hand, the value will be increase visibly.*

*4. Remove the tare: Press the menu into number one before the material on the tension detectors, meantime press the execution switch, the tension controller will get rid of the external weight of the tension detector to make the measure tension of the controller to be zero.*

5. Usage method: Choose the hand-operation to adjust the output proportion of the controller according to the tension that the material needs. Meantime, the measure tension is the tension of the material. Press the reset switch, the value of the measure tension will transfer to the setting tension, now press the auto switch that the tension controller will work automatically according to the value of the setting tension. If you need to adjust the tension, please press the adjusting switch. When the material finish and must alternate the reel, because of reel diameter of the material changes of lap that will make the tension changes of lap before or after the reel alternation. Meantime press the reset switch to make the output proportion of the tension controller returns to the output value of changing shaft (number 3 of the menu ), then eliminate a sudden change of the tension.

## Two. Elucidation of model number

**ZXT-B-600**

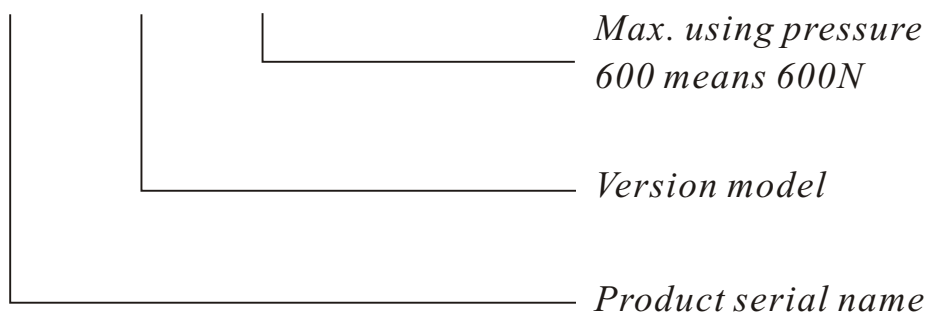

Three. Size of controller and tension detector

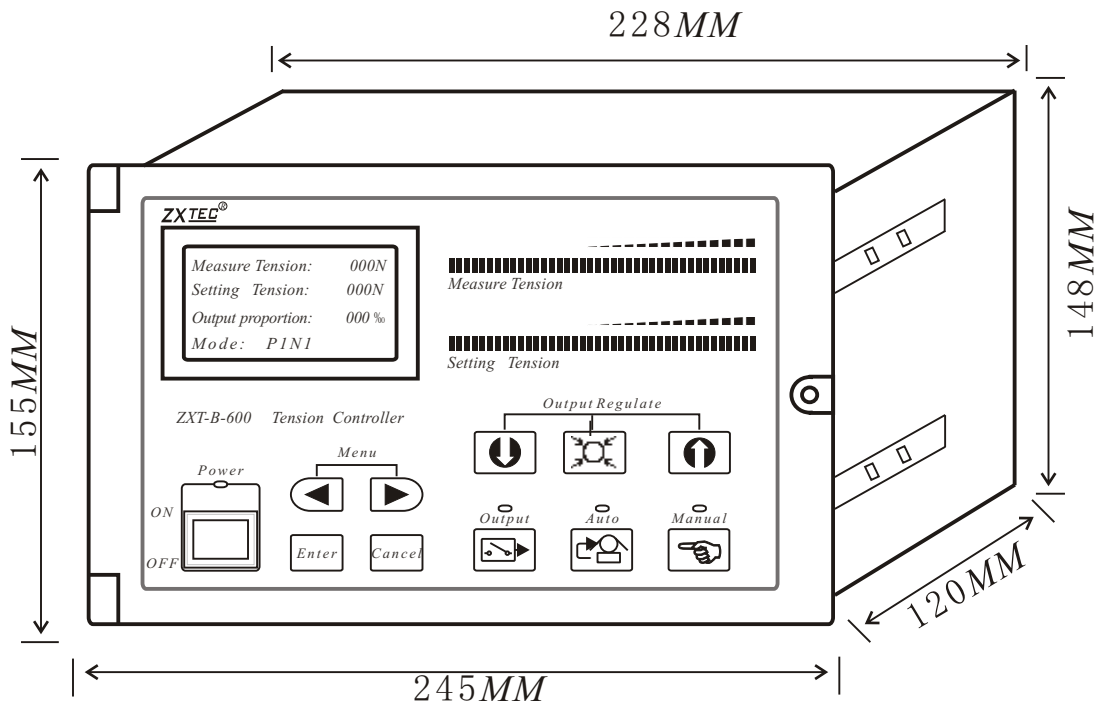

Four. Installing of tension detector

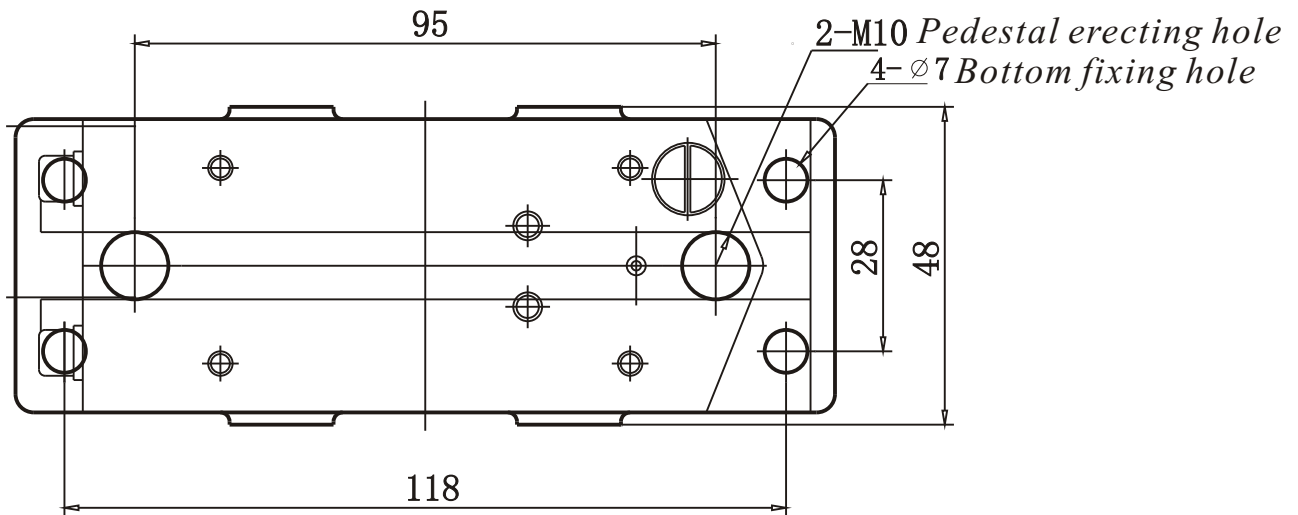

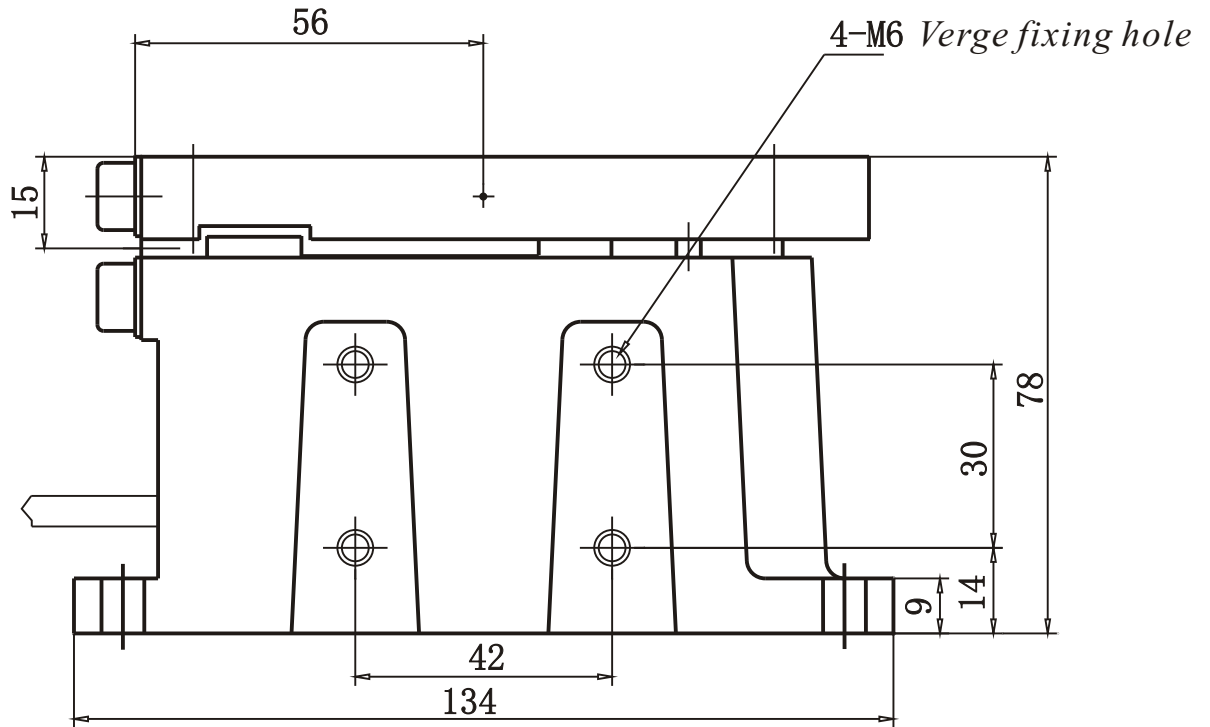

*Size of the tension detector*

*Four. Installing of tension detector*

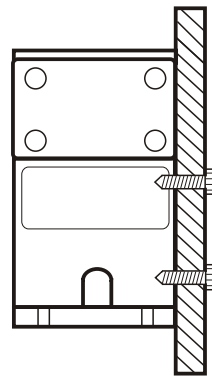
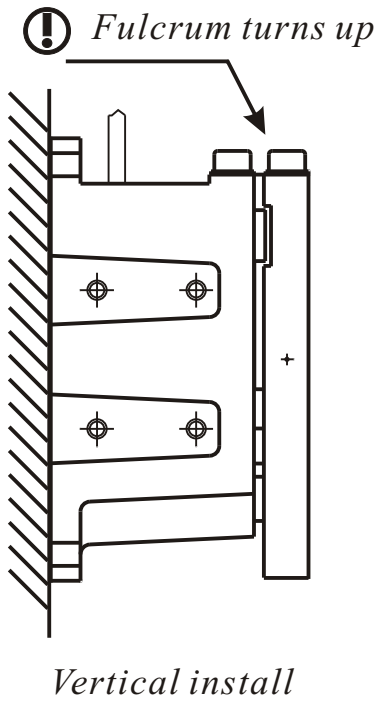

*Side install*

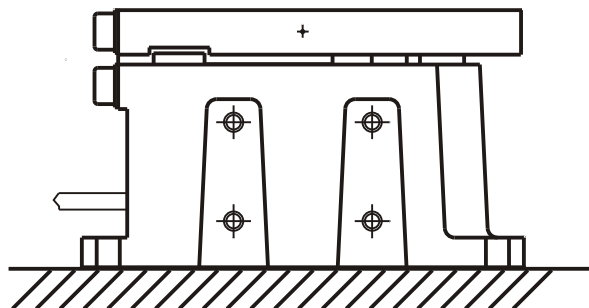

*Horizontal install*

# ZXTEC<sup>®</sup> ZXT-B Automatic Tension Controller P5

Install the tension detectors and select bottom or side fixing hole to firm. The position to install is fit between in vertical and horizontal angle. If vertical install please notice that the fulcrum of the tension detectors must be turns up.



## CAUTIONS

Installation screw of the tension detectors and pedestal can not be overlong. If overlong, it will lead the reed of the tension detectors can not work normally and detect no tensivity.

When exploit side installation, take heed of the fixing screw unable overlong, otherwise it will lead the measuring mechanism of the tension detectors damage.

Tension detectors whenever unable get a intension percussion or jarring, otherwise will lead the tension detectors damage.

## Five. Name and function of each parts of controller

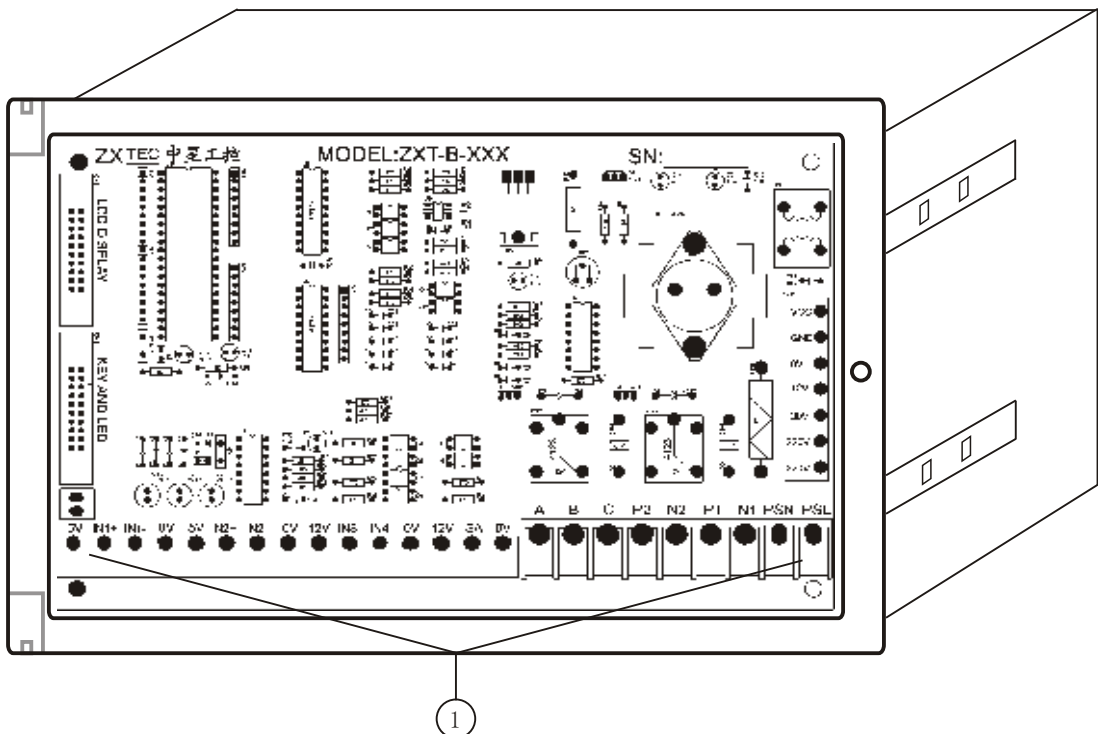

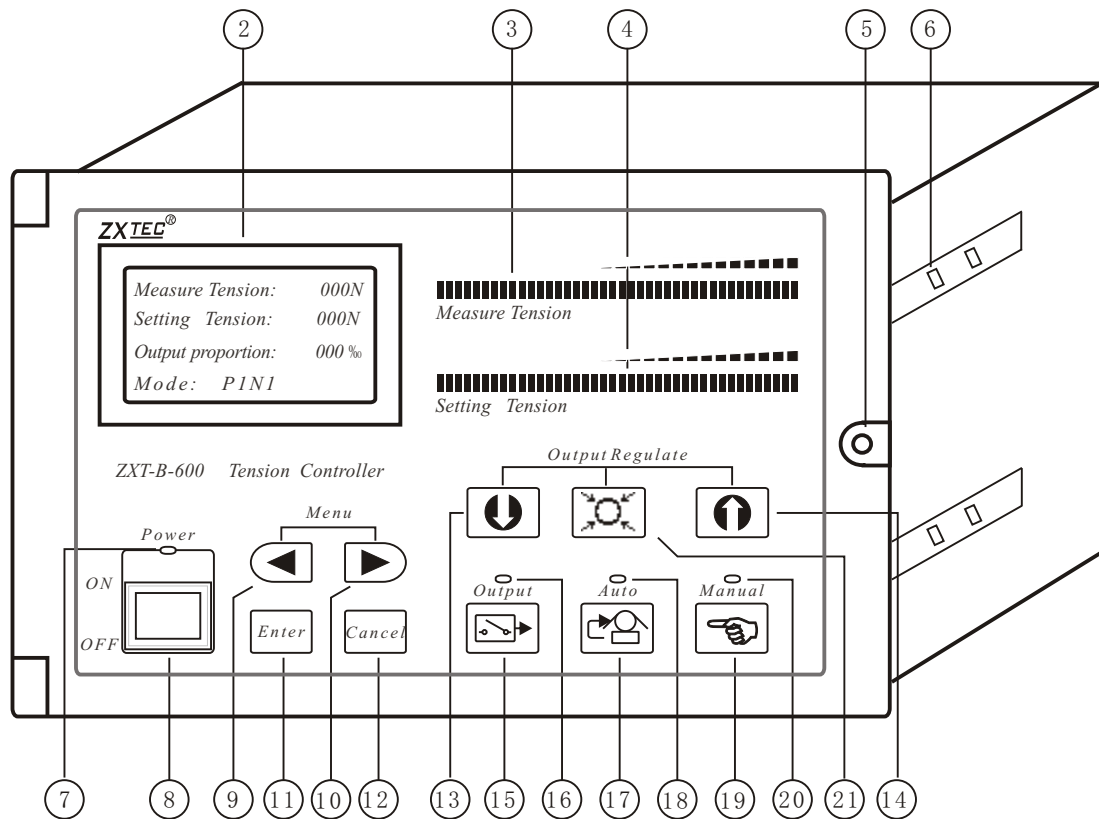

1. Wiring terminal: Connect input-output wire between the tension detectors.
2. Liquid crystal display monitor: It can select Chinese or English edition to display the data of controller.
3. 40 segment digital display: Display measure tension more visualized.
4. 40 segment digital display: Display positing tension more visualized.
5. Fix screw: The panel fix screw.
6. Fix hole: Mounting hole of table nip, for fixing the controller.
7. Indicating lamp of current source: Indicate the electric power supply state of controller.
8. Current source switch: The total current source switch of controller.
9. 10. Menu selecting switch: select number of setting menu.
11. Executive switch: The affirming switch under setting. By the way, when under the automatic state, press the executive switch can load the axle adjusting proportion to the output proportion.
12. Undo switch: The return switch under setting state.



- 13.14. *Adjusting switch: Adjust output proportion straightly by hand-operating; Adjust tension greater or smaller automatically; Adjust the data under setting state.*
15. *Output switch: Press it, the lamp 16 is on, output of controller P and N end are effective, when it is off, there is no output signal.*
17. *Automatic switch: Select switch by automatic mode, press it can select the controller works automatically and the lamp 18 is on.*
19. *Hand-operating switch: Select switch by hand-operating, press it can select controller works by hand-operating while the lamp 20 is on.*
21. *The reset switch of the tension: Press it, the value of the setting tension will change to be the current measure tension when it is on the state of the manual, otherwise on the state of the auto, the value of the output proportion will change into the proportion of the changing shaft.*

#### *Six. Work principle of tension controller*

*Under the automatic mode, work principle of the automatic constant tension controlling system is comparing the tension which tension detectors tested (namely the tension showed on LCD monitor) with positing tension (namely positing tension on the LCD monitor), if they are not equal, the controller adjust output proportion (namely output proportion on the LCD monitor) to make the magnetic powder brake clutch or servomotor etc. Modify moment of force; if they are equal, the controller keep output proportion, to make measure tension keep balance to positing tension.*

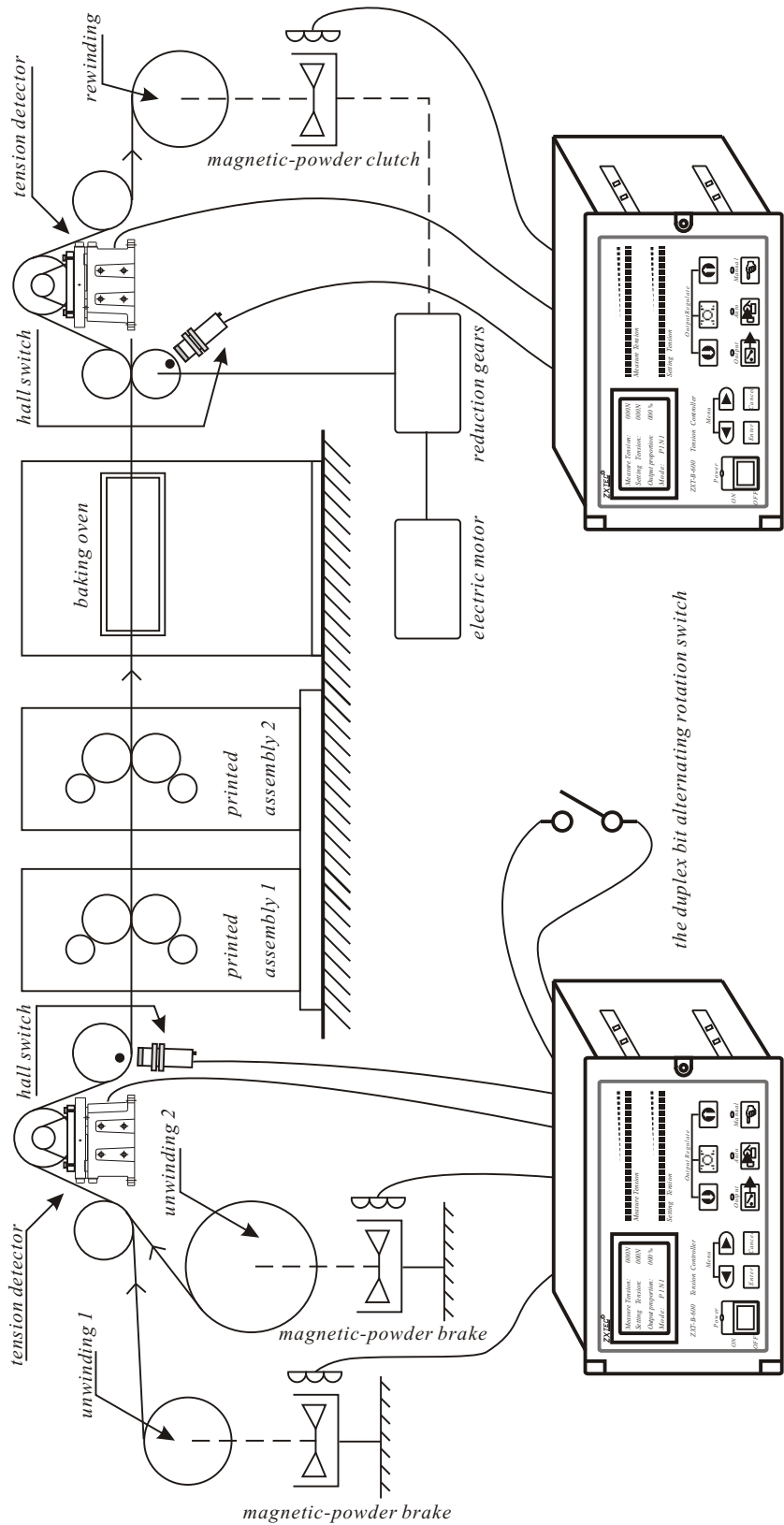

*the diagrammatic sketch of typical constant tension working*

## Seven. Wiring Diagram

Consumer should release control panel screw when on wiring diagram, open control panel to connect wire according to following wiring diagram.

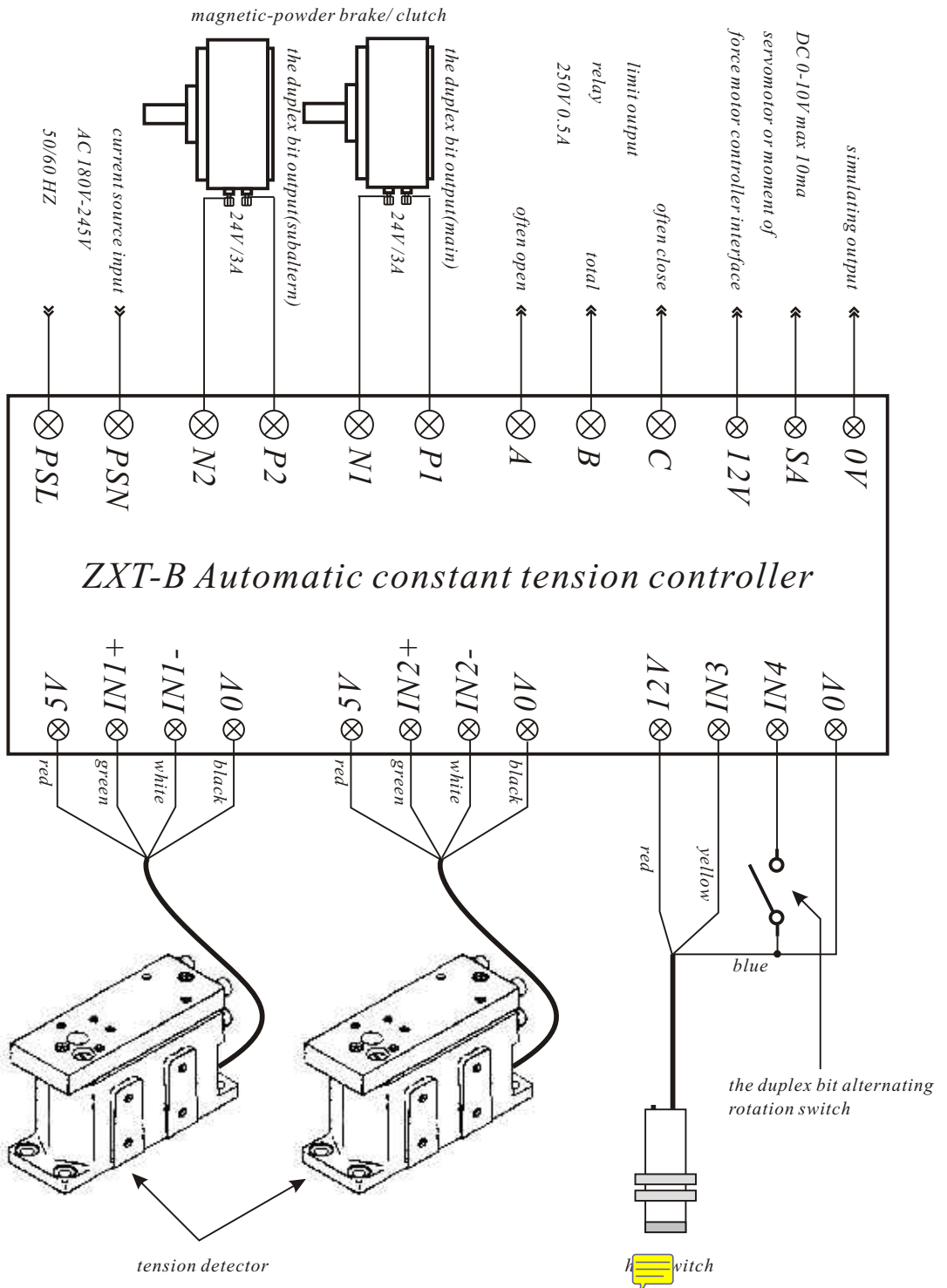

## Eight. Function of Hall switch

Depending on adjusting output proportion after comparing measure tension to positing tension, the automatic tension controller keep constant tension under automatic state, If rewinding stop, the tension gauge can not test measure tension in running and measure tension become small. If now the controller think measure tension less than positing tension and add output proportion, the tension will be too big for next running. So, when the system under automatic state, if it has not receive the signal of hall switch beyond 1 second, it will stop the adjustment of output proportion, at the same time, "missing" showed on the LCD monitor. As the following diagram:

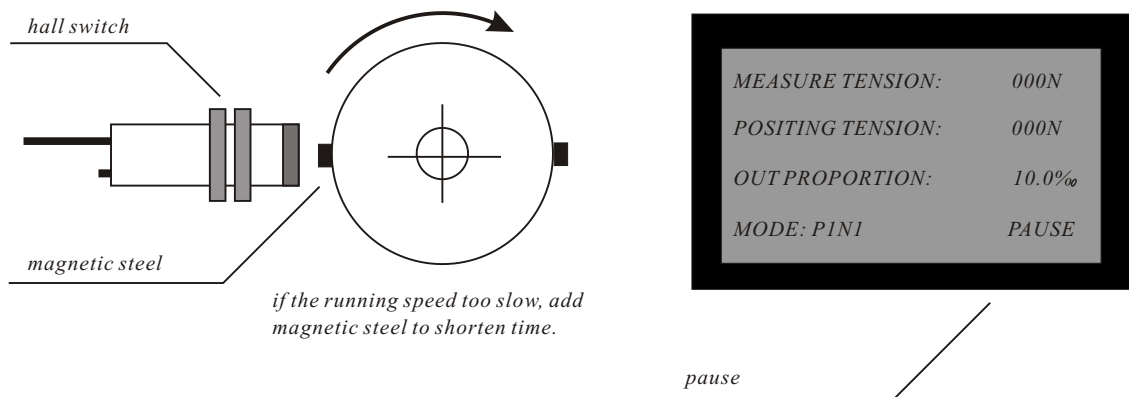

Notice: Magnetic steel has positive and negative

## Nine. Reason and function of limit output

The result of limit output is that the automatic tension controller adjust output proportion to limit namely 000% or 999% under automatic state, here the controller can not adjust the tension to constant tension, so run the limit relay to control the motor to stop or alarm.

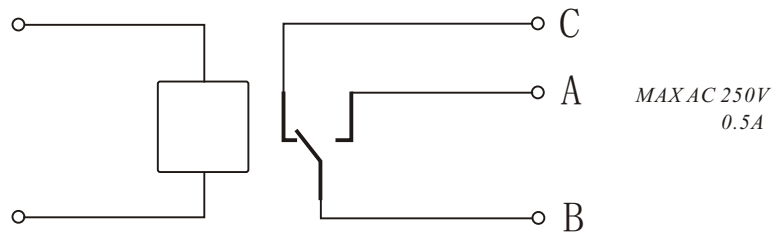

*limit output relay*

*Ten. Convert switch of duplex bit*

*The controller is suitable for two station rewinding and unwinding.*

*Consumers can set axis-change output proportion according to the machine speciality, to make the controller set new output proportion to the axis when the main and auxiliary axes change and to make the tension of axis near the setting tension to shorten the axis change course.*

*Eleven. Analogue output*

*There are not only two 24V constant current output drive magnetic-powder brake clutch but also a 0-10V simulating signal output drive servomotor or moment of force motor, meantime, they are suitable for showing controller output proportion.*

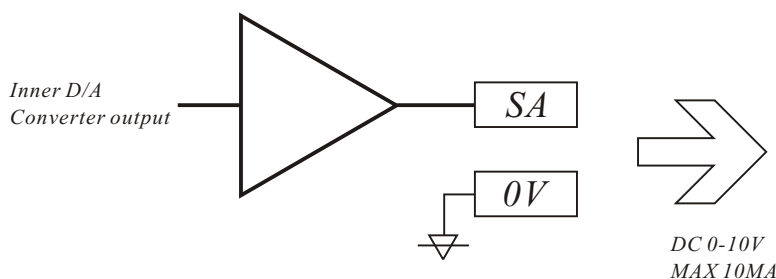

*Twelve. Setting parameter*

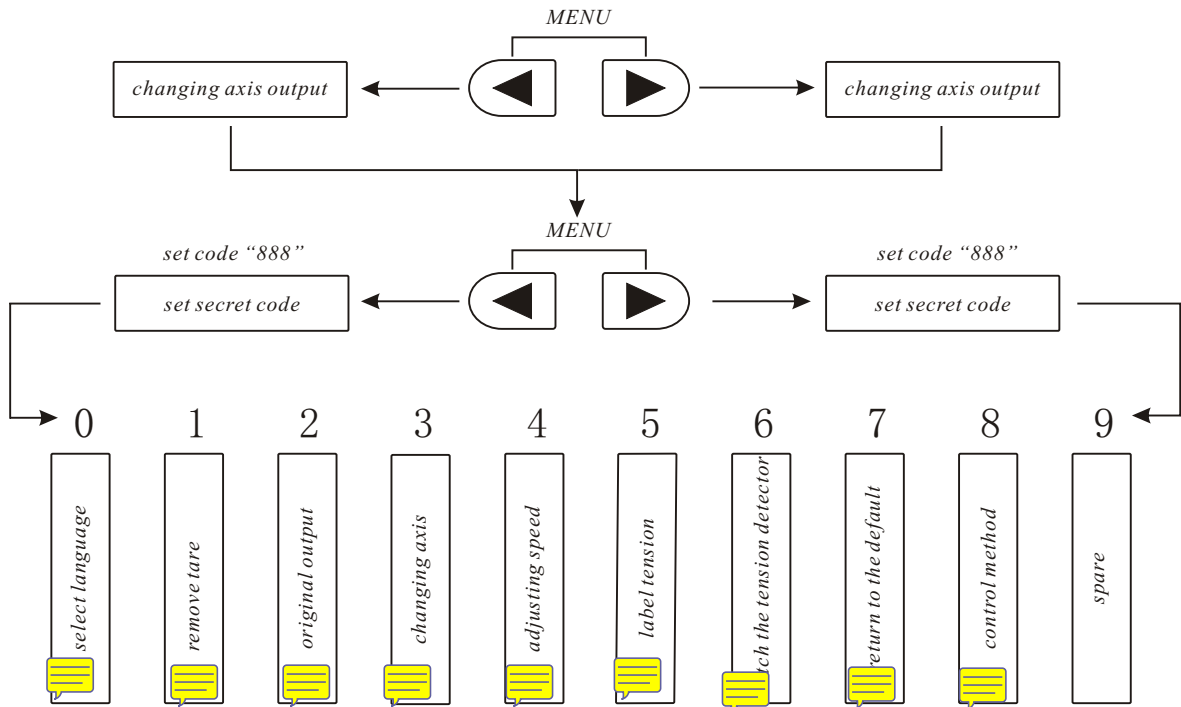

0) *Language Select: Consumers can select Chinese or English to display.*

1) *Remove Tare: Remove weight of the guide roller and axletree on the tension gauge.*

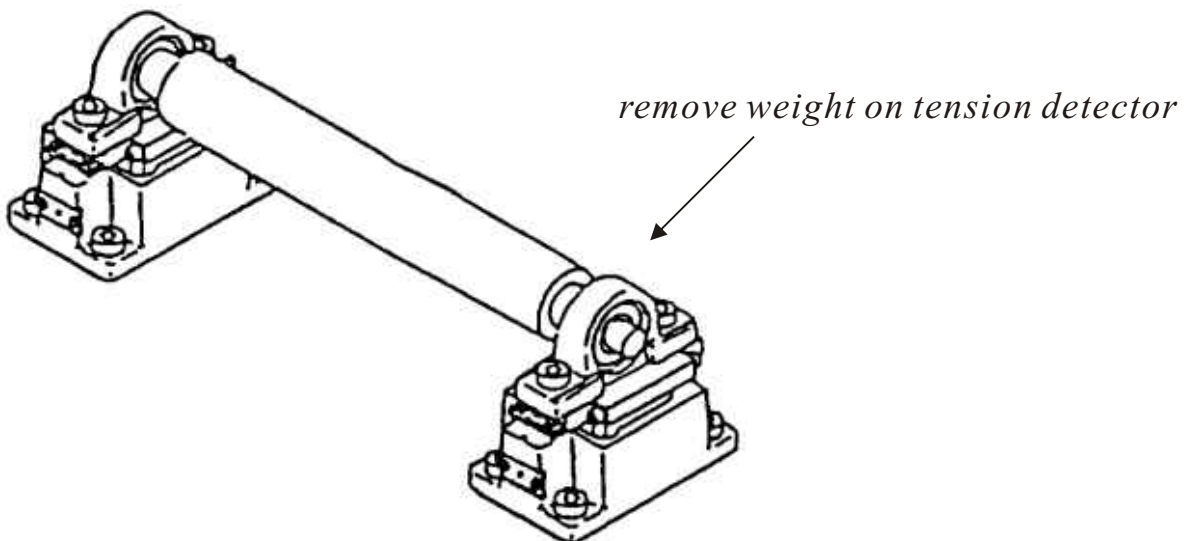

- 2) *Original Output: The big and small of original output decide which of the controller output proportion. The order is make the tension of the original output corresponding near the setting tension to make the measure tension keep balance to the setting tension in shorten time when the controller electrified.*
- 3) *Axis-changed Output: The big and small of axis-change output decide which of the controller. When user use the two station rewinding and unwinding to change axis, the tension will change too. So set the changing output to change the output proportion and reduce the change of tension.*
- 4) *Adjust speed: When the controller works under automatic state, the measure tension and setting tension are not equal, the controller adjust the output proportion by adjusting the speed. When the speed is 0, it is the fastest; when the speed is 9, it is the slowest.*
- 5) *Demarcate tension*

*The function of it is adjusting controller measure tension, the method as the drawing:*

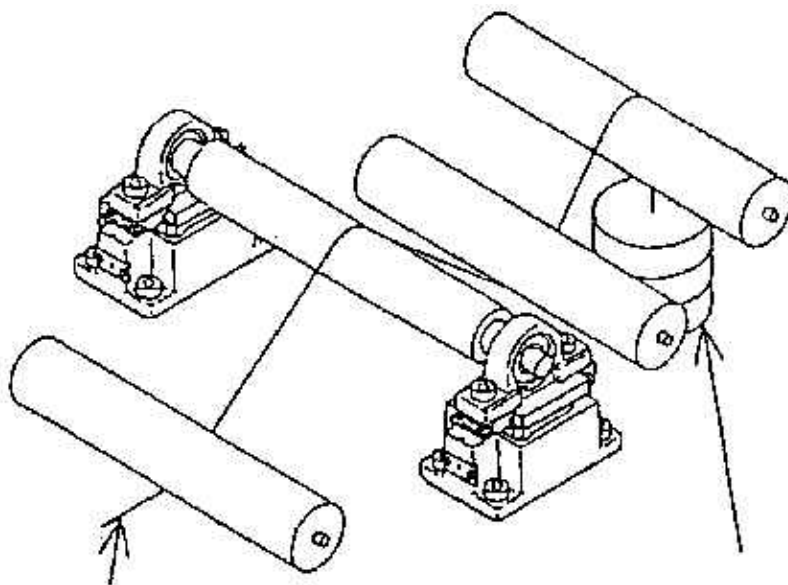

*let the line at the middle of  
two tension test device*

*the hanging weight  
near the total tension*

*Process:*

- a) First get rid of the tare a time before the demarcating weight was added to the tension device, to make the measuring tension back to ;0;.*
- B) Inflict tension to the test device as drawing, input the demarcating tension according the actual weight, then press ;execute; finish the demarcating tension.*
- 6. Watch the tension sensor: It checks that the analogue value of the two tension sensors whether normal or not. If you install the tension sensors not well and make them damaged, you can see them output analogue whether normal or not in this item of the menu. When there is nothing on them that the value is 1000-20000, if the analogue value is less than 1000 or more than 20000, please check the tension sensors installing whether right or not.*
- 7. Return to the default: Interior parameter of the tension controller returns to the default which is set before leaving the factory.*
- 8. Control method: It can select the feedback, winding taper and unwinding taper tension. The default is feedback tension which is according to the setting tension and measure tension adjust to output proportion correspondingly and realize to control the tension permanence automatically totally. When you select the winding taper of unwinding taper to control that according to the Hall switch outside repeat to pick up the pulse amount which made by the materials pass the guide rod reaches to the set pulse amount, then the tension controller adjusts the output proportion and the reel diameter of the reel canister changes change the taper tension fogging, this method is simple and easily install that is suit for the scene of not high request to be constant tension control.*