

HMNS - SELF CONTAINED NUT SPLITTERS



Capacities from 17 to 50mm AF

Choice of 3 models

Compact & easy to use

The HMNS range of hydraulic nut splitters offers a choice of 3 models suitable for hexagon nut AF sizes from 17 to 50mm (M10 to M33 bolt sizes). All models have an angled body design to provide the necessary clearance on flanges and flat surfaces. The revolutionary design incorporates a hardened steel linkage that ensures the blades cutting edge is kept parallel to the nut throughout the splitting process which improves operational efficiency and more importantly, blade life. Designed to easily split corroded nuts up to RC44 hardness, Hi-Force nut splitters offer the ideal 'cold cut' solution for removing worn or corroded fasteners, especially in applications where 'hot work' permits are not allowed. All models incorporate an integral hydraulic pump with multi-positional lever for even greater versatility.

- >> Angled body design on all models
- >> Provides necessary clearance on flanges and flat surfaces
- >> Manufactured from high quality steel

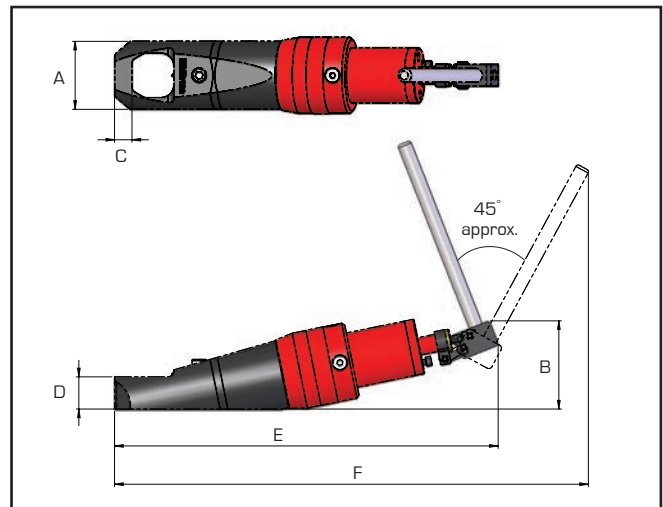

Model number	Hexagon AF sizes		Bolt sizes		Weight kg
	mm	inch	metric	imperial	
HMNS104	17 - 32	11/16" - 1 1/4"	M10 - M22	1/2" - 3/4"	5.8
HMNS110	32 - 41	1 1/4" - 1 5/8"	M22 - M27	3/4" - 1 5/8"	7.9
HMNS200	41 - 50	1 5/8" - 2"	M27 - M33	1" - 1 1/4"	13.6

Dimensions in mm					
A	B	C	D	E	F
64	88	12.5	30.0	380	455
78	101	20.0	37.0	440	540
94	112	21.0	43.0	471	566

Note: The HMNS nut splitters are for use on heavy duty nuts, where the nut height is equal to or greater than two-thirds of the blade length of the tool being used.

Replacement blades for HMNS nut splitters :

Blade Part number	For Nut splitter
NS104-B	HMNS104
NS110-B	HMNS110
NS200-B	HMNS200

